

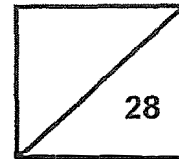

Rosyth School  
Weighted Assessment 2024 (Term Two)  
SCIENCE  
Primary 5

Name: \_\_\_\_\_

Total  
Marks:



Class: Pr 5 \_\_\_\_\_

Register No. \_\_\_\_\_

Date: 7 May 2024

Duration: Total Time for Booklet A and B: 1h

---

---

## Booklet A

### Instructions to Pupils:

1. Do not open the booklet until you are told to do so.
2. Follow all instructions carefully.

\* This booklet consists of 10 printed pages (including this cover page).

For each question from 1 to 14, four options are given. One of them is the correct answer. Make your choice (1, 2, 3 or 4) and shade your answer on the Optical Answer Sheet.

[28 Marks]

1 Which one of the following below represents an animal cell?

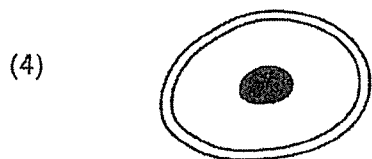
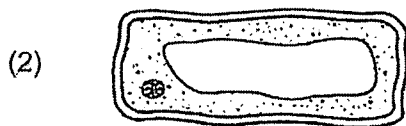
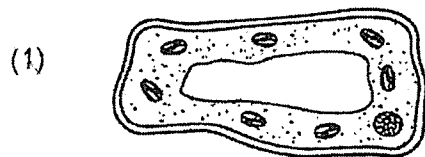

2 Which of the following shows the correct function of its cell part?

	Cell part	Function
(1)	Cell wall	Does not allow substances to enter or leave the cell
(2)	Nucleus	Controls substances that enter and leave the cell
(3)	Cytoplasm	Allows substances to move within the cell
(4)	Cell membrane	Allows all substances to enter or leave the cell

3 Arif wanted to find out if the number of roots affects the volume of water absorbed by the plant. He carried out an experiment at the same place using the two set-ups, A and B, as shown below.

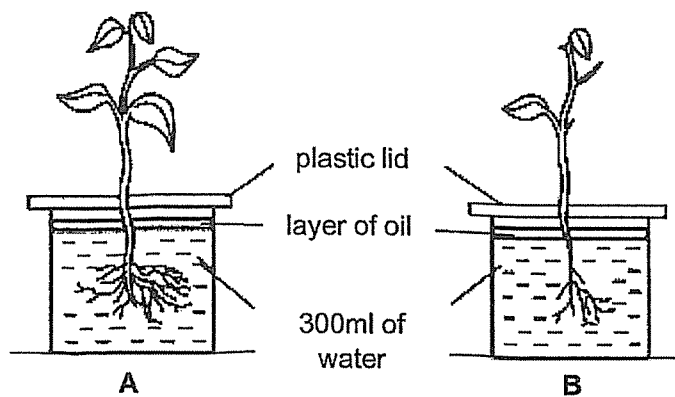

Arif's teacher told him that the experiment was not fair. Which of the following should he do to make his experiment a fair test?

- (1) Put each set-up at a different place
- (2) Remove the layer of oil from both set-ups
- (3) Use plants with the same number of roots
- (4) Use plants with the same number of leaves

- 4 Which statement is correct about the transport systems for plant and fish?
- (1) Oxygen is transported in the plant transport system but not in the fish transport system.
  - (2) Carbon dioxide is transported in the fish transport system but not in the plant transport system.
  - (3) Food and water are transported in the same tube in both the plant and fish transport systems.
  - (4) Food and water are transported in different types of tubes in both the plant and fish transport systems.
- 5 Karl had an accident and both his legs were badly injured. After recovery, his legs were replaced with artificial ones, Part X.

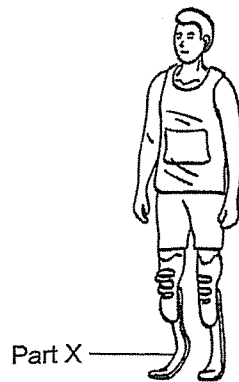

Part X enables Karl to walk and run. Which body system does Part X belong to?

- (1) Skeletal system
- (2) Digestive system
- (3) Circulatory system
- (4) Respiratory system

6 Which of the following best represents the composition of inhaled and exhaled air?

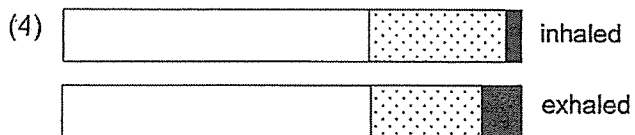
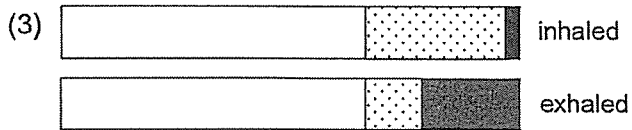
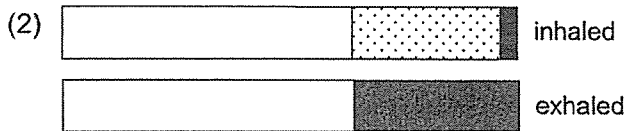
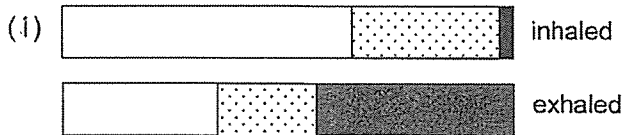
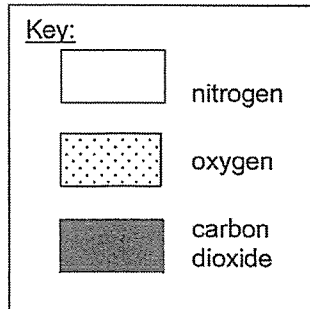

- 7 The diagram below shows that the blood vessels under the skin widen when the surrounding temperatures are higher than usual.

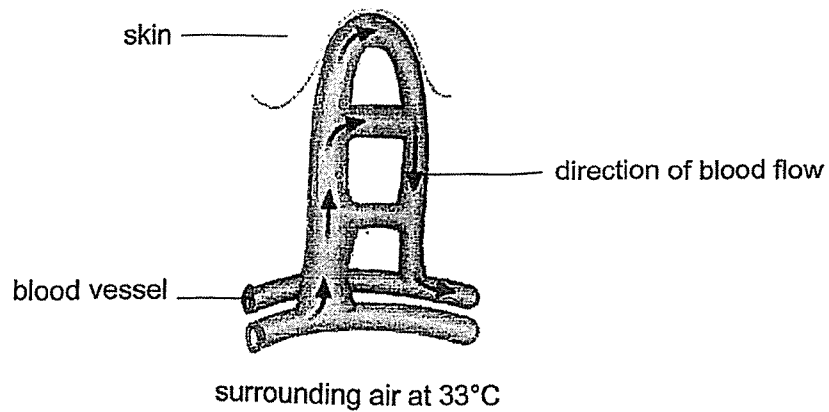

Which human system is involved and how does this help our body to adapt at higher surrounding temperatures?

	Human system	Reason
(1)	Circulatory	Blood flow increases so more heat is lost.
(2)	Circulatory	Blood flow decreases so less heat is gained.
(3)	Respiratory	Blood flow increases so more heat is lost.
(4)	Respiratory	Blood flow decreases so less heat is gained.

- 8 Two cups, A and B, contained the same volume of water. Joshua measured the temperature of water in both cups and recorded the temperatures as shown below.

Cup A	Cup B
75 °C	10 °C

Joshua poured all the water from both cups into a basin of water at room temperature (25 °C).

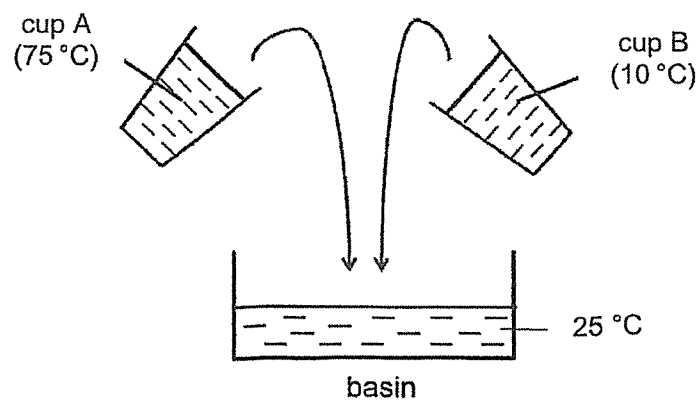

What could be the possible temperature of the water in the basin after six hours?

- (1) about 25 °C
- (2) lower than 25 °C
- (3) lower than 10 °C
- (4) higher than 75 °C

- 9 Some water was measured in a syringe as shown below.

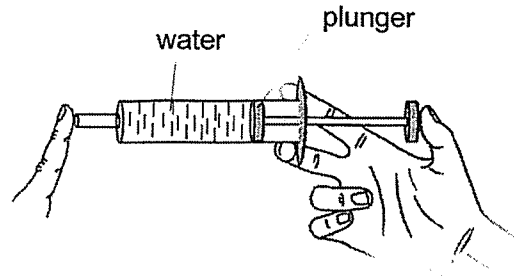

When the plunger was pushed, it did not move. What property of water was shown in this experiment?

- (1) The water has mass.
  - (2) The water takes up space.
  - (3) The water cannot be compressed.
  - (4) The water does not have a definite shape.
- 10 Figure 1 shows an inflated balloon filled with air, floating on water in a glass container. When the balloon was pushed downwards, some water in the container overflowed as shown in Figure 2.

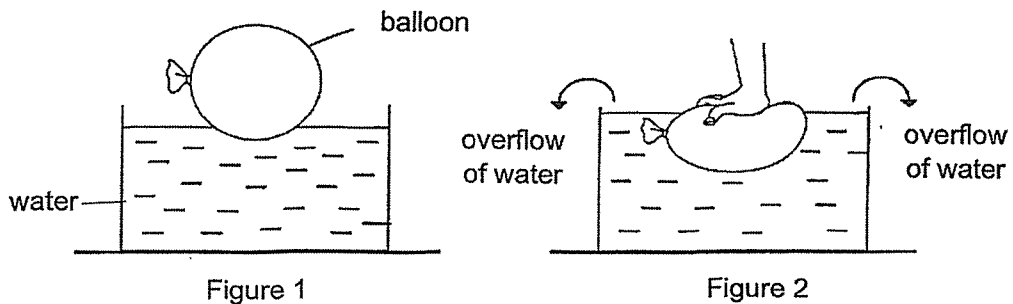

Which one of the following explains why some water overflowed in Figure 2?

- (1) All matter has mass.
- (2) All matter occupies space.
- (3) All matter has a definite shape.
- (4) All matter has a definite volume.



Refer to the information below to answer Questions 11 and 12.

Suzy heated a beaker of water. When the water boiled for five minutes, she stopped heating and recorded the temperature of water every five minutes. Her results are as shown in the graph below.

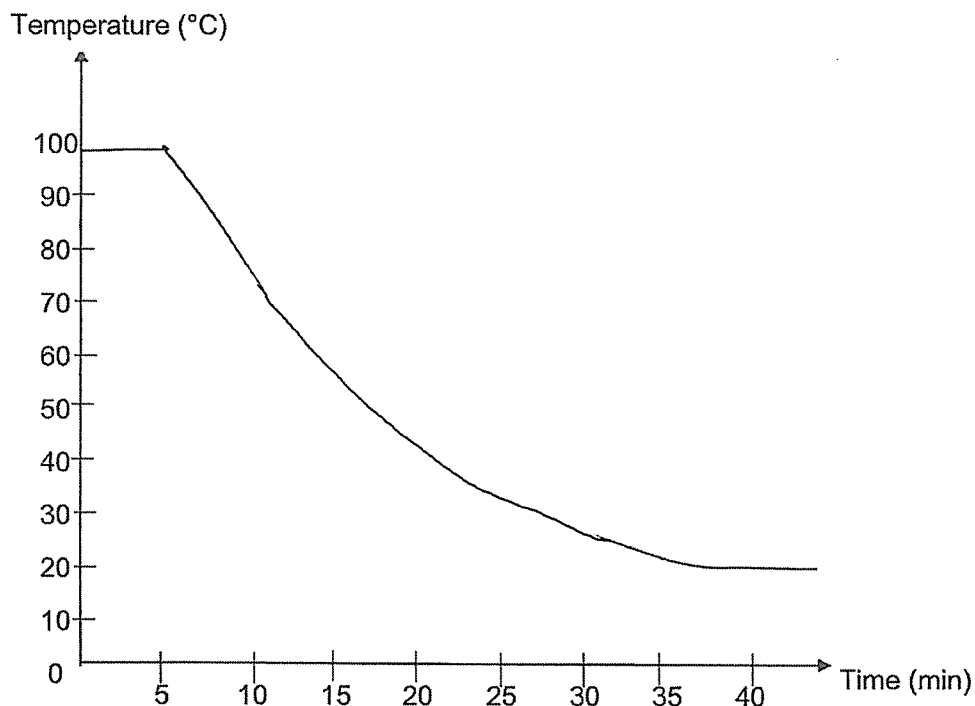

11 What is happening to the water from 0 minutes to 5 minutes?

- (1) Water exists as a liquid state only.
- (2) The temperature of water increases.
- (3) Water changes in state from gas to liquid.
- (4) Water gains heat and undergoes a change in state.

12 What is the room temperature?

- (1) 20 °C
- (2) 30 °C
- (3) 40 °C
- (4) 100 °C

13 Which of the following processes involves heat loss?

- (1) boiling
- (2) melting
- (3) freezing
- (4) evaporation

14 Aishah made a tray of blue coloured ice with blue dye and water. She took the blue coloured ice and placed them in a beaker on the table. 30 minutes later, she noticed liquid X was formed on the table as shown in the diagram below.

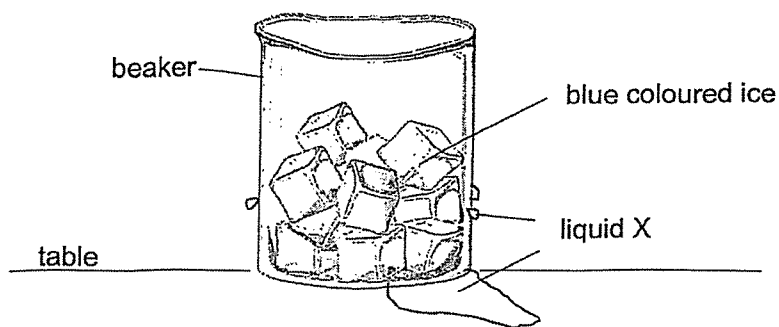

What is the colour of liquid X and state the process that resulted in liquid X.

	Colour of liquid X	Process
(1)	Blue	Melting
(2)	Blue	Condensation
(3)	Colourless	Melting
(4)	Colourless	Condensation

(Go to Booklet B)



**Rosyth School**  
**Weighted Assessment 2024 (Term Two)**  
**SCIENCE**  
**Primary 5**

Total  
Marks:

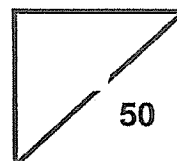

Name: \_\_\_\_\_

Class: Pr 5 \_\_\_\_\_

Date: 7 May 2024

Duration: Total time for Booklet A and B: 1 h

## Booklet B

Instructions to Pupils:

1. Please do not turn this page until you are told to do so.
2. Follow all instructions carefully.
3. Answer all questions.

	<b>Maximum</b>	<b>Marks Obtained</b>
<b>Booklet A</b>	<b>28 marks</b>	
<b>Booklet B</b>	<b>22 marks</b>	
<b>Total</b>	<b>50 marks</b>	

\* This booklet consists of 10 printed pages (including this cover page).

For questions 15 to 20, write your answers in this booklet.

(22 marks)

15 Two cells, P and Q, shown below were taken from different parts of a plant.

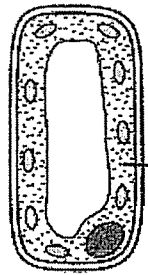

cell P

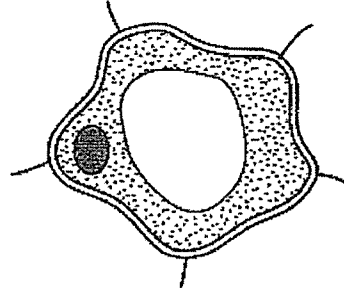

cell Q

(a) Which cell, P or Q, is needed for the plant to make food? Explain your answer. [2]

---

---

(b) In the diagram above, label the cytoplasm in cell P. [1]

- 16 Study the diagram below. The arrows represent the direction of movement of substance M and digested food between the human circulatory and digestive systems.

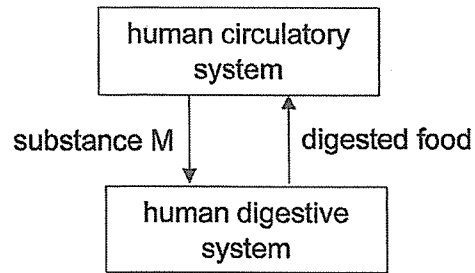

- (a) Name the part in the human digestive system where digested food is absorbed into the blood. [1]

---

- (b) Name substance M that is found in the blood. [1]

---

The graph below shows the volume of blood flow per minute to the leg muscles and small intestine while Alex is exercising or eating.

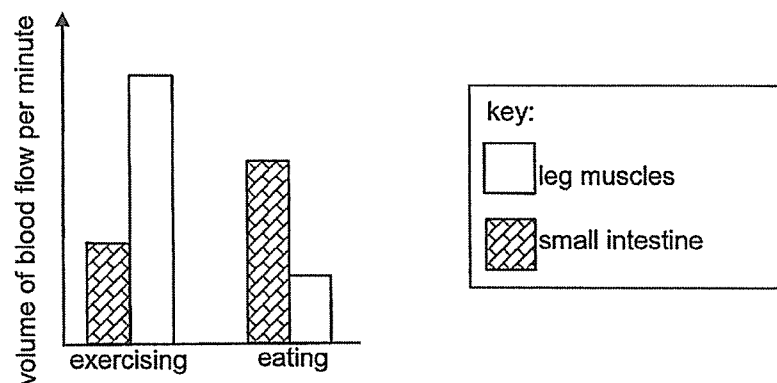

- (c) During which activity, is the volume of blood flow to the small intestine lower?

Tick (✓) your answer below. [1]

exercising

eating

3 [Question 16 is continued on page 4]

- (d) Based on the graph, explain how exercising after a meal affects the absorption of digested food in the small intestine. [1]

---

---

- 17 The diagram below shows how water and food are transported in a plant. X and Y represent different parts of a plant. The arrows represent the direction of movement of water and food in a plant.

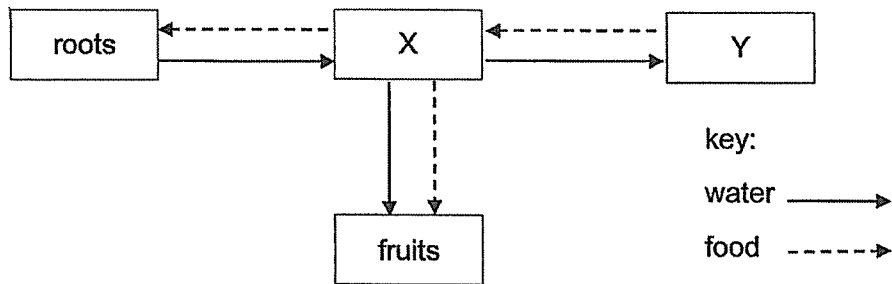

- (a) Identify parts, X and Y. [2]

X: \_\_\_\_\_

Y: \_\_\_\_\_

[Question 17 is continued on page 5]

Andy removed an outer ring from the stem of two similar plants, A and B, as shown below. The food-carrying tubes were removed while the water-carrying tubes remained in the stems. Both plants were given the same volume of water and placed in the same garden.

After a week, he observed that one of the plants died while the other remained alive.

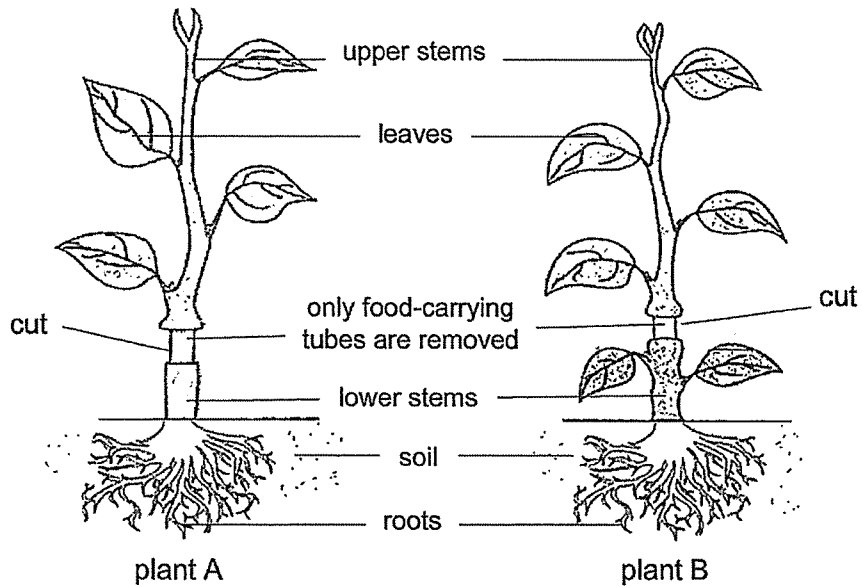

(b) Which plant, A or B, died after a week? Explain why. [2]

---



---



---



---

- 18 A company made a new material called 'Heatwarm'. They want to use 'Heatwarm' to make winter coats. A scientist tested the heat conductivity of 'Heatwarm' using materials A, B and C as shown below.

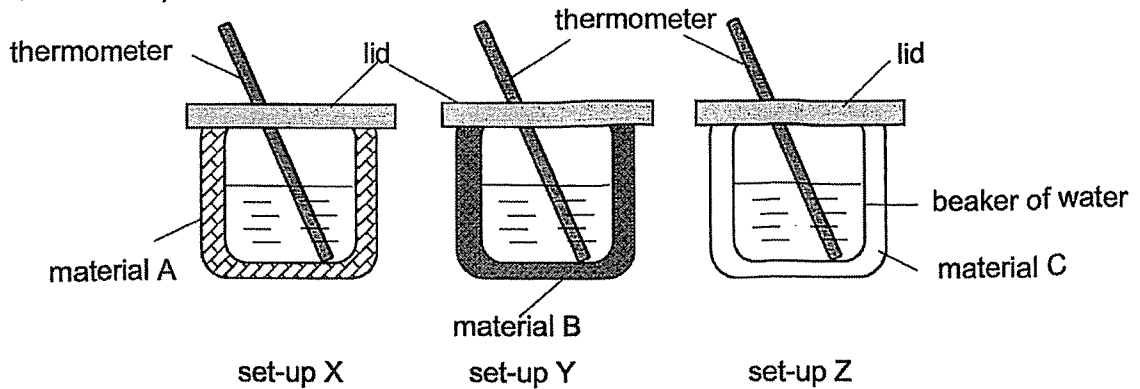

She wrapped each beaker of water in a different material, A, B and C. She recorded the temperature of the water at the start of the experiment and 20 minutes later.

- (a) Identify the changed variable(s), measured variable(s) and unchanged variable(s) in this experiment. Tick the correct box. [2]

	Changed variable	Measured variable	Unchanged variable
Type of material			
Temperature of water in the beaker after 20 minutes			
Volume of water			
Size of the beaker			

[Question 18 is continued on page 7]



The results of the experiment are shown below.

Time (min)	Temperature of water (°C) in the set-up after 20 minutes		
	Set-up X	Set-up Y	Set-up Z
0	60	60	60
20	34	40	52

- (b) Based on the results above, which material is most suitable to make winter coats? Explain your answer. [2]

---

---

- (c) The scientist also wanted a control set-up. Draw and label clearly, the control set-up in the box below. A drawing of a beaker has been done for you. [1]

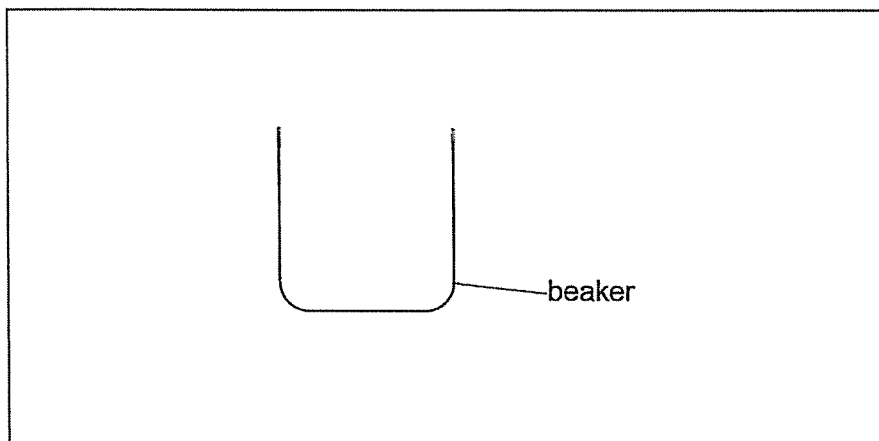

- 19 Jerry and Letisha wanted to find out how quickly matter X flows at different temperatures. Jerry poured some matter X into a cup with a hole at the bottom. Letisha measured the time it took for 20 ml of matter X to drip out of the cup.

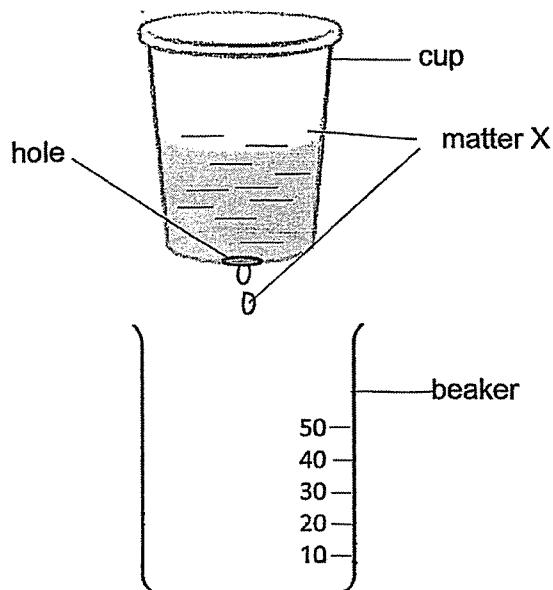

- (a) What is the state of the matter X? [1]
- 
- (b) Assuming all of matter X flows into the beaker, draw on the beaker the volume of matter X. [1]

[Question 19 is continued on page 9]

They repeated this experiment with matter X heated to 30 °C, 35 °C and 40 °C. They recorded their results on a graph.

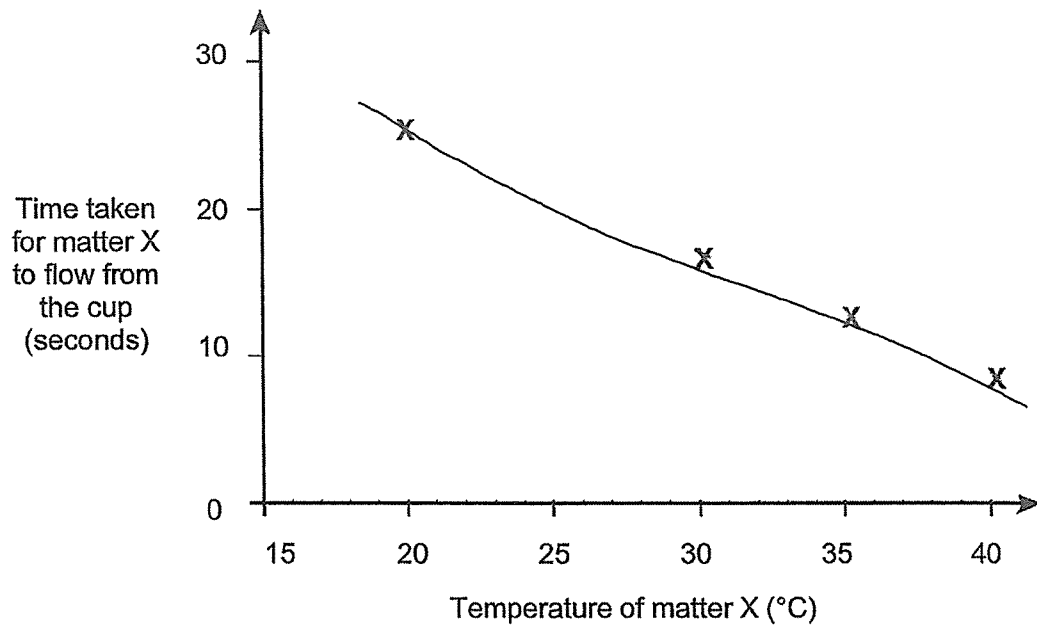

- (c) What is the relationship between the temperature of matter X and the time taken for matter X to flow from the cup? [1]

---

---

20 Jamil placed 5ml of water in his hands and 5ml of water on the table.

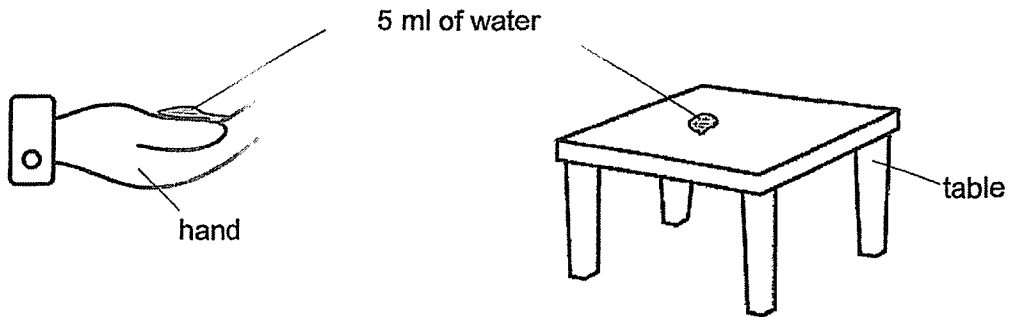

(a) State the change in state when water evaporates from Jamil's hand. [1]

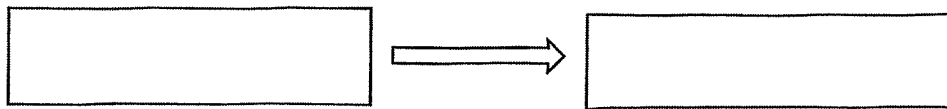

(b) Explain how the water on Jamil's hand and the water on the table disappeared after some time. [2]

Water on Jamil's hand: \_\_\_\_\_

\_\_\_\_\_

\_\_\_\_\_

Water on the table: \_\_\_\_\_

\_\_\_\_\_

\_\_\_\_\_

**End of paper**

SCHOOL : ROSYTH PRIMARY SCHOOL

LEVEL : PRIMARY 5

SUBJECT : SCIENCE

TERM : 2024 WA2

---

Q1	Q2	Q3	Q4	Q5	Q6	Q7	Q8	Q9	Q10
3	3	4	2	1	4	1	1	3	2

Q11	Q12	Q13	Q14
4	1	3	4

**BOOKLET B**

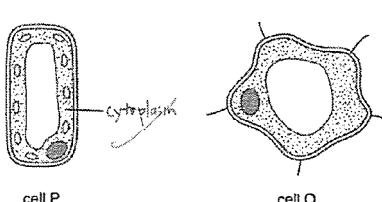
Q15)	<p>a) Cell P is needed for the plant to make food. There is chloroplast in the cell that contains chlorophyll to trap sunlight for making food.</p> <p>b)</p>  <p>cell P</p> <p>cell Q</p>
Q16)	<p>a) Small intestine.</p> <p>b) Oxygen.</p> <p>c) Exercising</p> <p>d) During exercise, the flow of blood per minute to the small intestine decrease so the absorb plan of digested food in the small intestine decreases.</p>

Q17)

- a) X: stem  
Y: leaves

b) Plant A died. When the food-carrying tubes are removed, the food-carrying tubes of the plant can no longer travel the food made by the leaves down to the roots in plant A therefore, without food in the roots to absorb water, it died.

Q18)

a)

	Changed variable	Measured variable	Unchanged variable
Type of material	✓		
Temperature of water in the beaker after 20 minutes		✓	
Volume of water			✓
Size of the beaker			✓

b) Material C. It lost the least heat to the surroundings, therefore is the most suitable for a winter coat. The temperature of the water change after 20 minutes is the least so material is the poorest conductor of heat.

c)

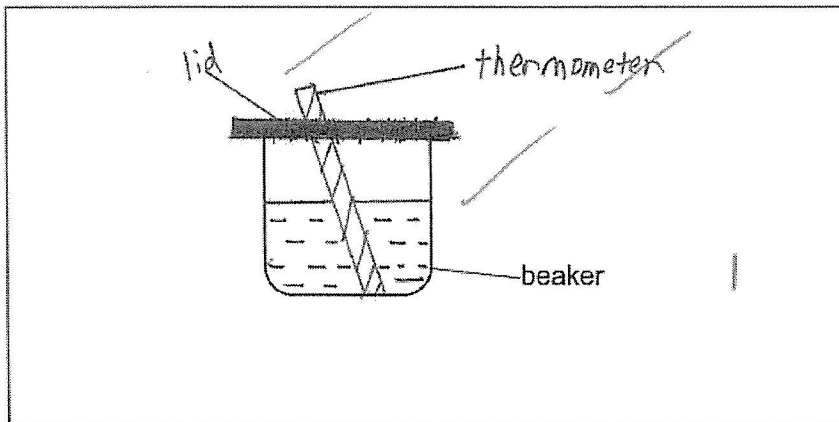

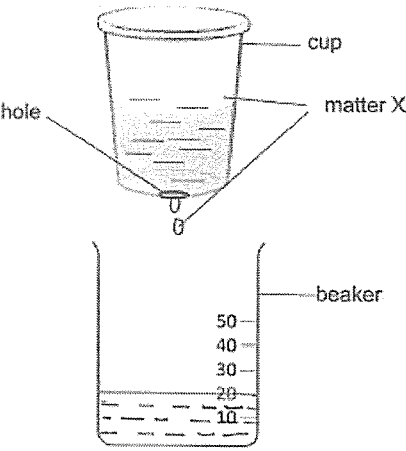
<p><b>Q19)</b></p>	<p><b>a) Liquid state.</b></p> <p><b>b)</b></p>  <p><b>b) The greater the temperature of matter X, the lesser the time taken for matter X to flow the cup.</b></p>
<p><b>Q20)</b></p>	<p><b>a) liquid → gaseous</b></p> <p><b>b) Water on Jamil's hand : It gained heat from his hand and evaporated .</b></p> <p><b>Water on the table: It gained heat from the surrounding and evaporated.</b></p>

