



NANYANG PRIMARY SCHOOL

**TERM 1 WEIGHTED ASSESSMENT  
2023**

**PRIMARY 6**

**MATHEMATICS  
PAPER 1  
(BOOKLET A)**

Total Duration for Booklets A and B: 1 hour

Additional materials: Optical Answer Sheet (OAS)

**INSTRUCTIONS TO PUPILS**

1. Do not turn over this page until you are told to do so.
2. Follow all instructions carefully.
3. Answer all questions.
4. Shade your answers in the Optical Answer Sheet (OAS) provided.
5. The use of calculators is **NOT** allowed.

Name: \_\_\_\_\_ (      )

Class: Primary 6 (      )



Questions 1 to 10 carry 1 mark each. Questions 11 to 15 carry 2 marks each. For each question, four options are given. One of them is the correct answer. Make your choice (1, 2, 3 or 4) and shade your answer on the Optical Answer Sheet. (20 marks)

---

1 Janice is  $\frac{5}{7}$  as tall as Xiao Ming. What is the ratio of Xiao Ming's height to Janice's height?

(1) 5 : 7

(2) 7 : 5

(3) 5 : 12

(4) 7 : 12

2 A pail contains 28 ℓ of water. A tank contains 800 times as much water as the pail. How many litres of water are there in the tank?

(1) 16 400 ℓ

(2) 22 400 ℓ

(3) 64 400 ℓ

(4) 224 000 ℓ

3 What is the value of  $\frac{2}{3} + \frac{1}{5}$  ?

(1)  $\frac{3}{8}$

(2)  $\frac{3}{15}$

(3)  $\frac{2}{15}$

(4)  $\frac{13}{15}$

4 In the number line below, what is the value of  $X$  ?

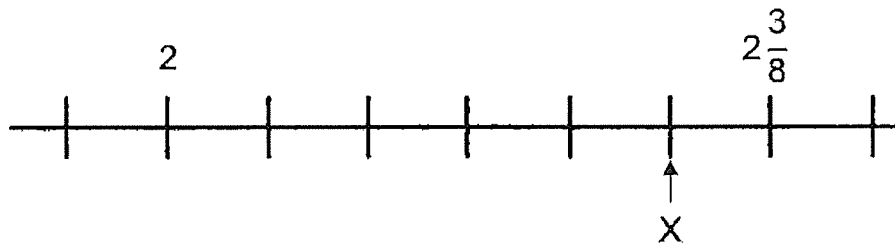

(1)  $2\frac{1}{4}$

(2)  $2\frac{3}{15}$

(3)  $2\frac{5}{16}$

(4)  $2\frac{1}{2}$

5 What is the value of  $\frac{3}{7} \times \frac{5}{2}$ ?

(1)  $\frac{8}{9}$

(2)  $\frac{15}{14}$

(3)  $\frac{15}{9}$

(4)  $\frac{6}{35}$

6  $\frac{3}{4}$  of a pizza was shared equally among 5 people. What fraction of the pizza did each person receive?

(1)  $\frac{3}{20}$

(2)  $\frac{4}{15}$

(3)  $\frac{20}{3}$

(4)  $\frac{7}{45}$

7 Express 10.01 kg in kilograms and grams.

- (1) 1 kg 1 g
- (2) 10 kg 1 g
- (3) 10 kg 10 g
- (4) 100 kg 10 g

8 Ninety identical pencils cost \$57.60. What is the cost of one such pencil?

- (1) \$0.54
- (2) \$0.64
- (3) \$0.74
- (4) \$6.40

9 Sathya had 250 fruits. 50 of them were papayas, 110 of them were mangoes and the rest were pears. What percentage of her fruits were pears?

- (1) 20%
- (2) 36%
- (3) 44%
- (4) 64%

- 10 Which one of the following is likely to be the mass of a honeydew sold in a supermarket?

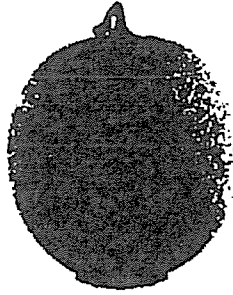

- (1) 2.5 g  
(2) 25 g  
(3) 2.5 kg  
(4) 250 kg
- 11 The length, breadth and height of a box are in the ratio 3 : 2 : 1 respectively. The length of the box is 6 cm. Find the volume of the box.
- (1) 12 cm<sup>3</sup>  
(2) 18 cm<sup>3</sup>  
(3) 36 cm<sup>3</sup>  
(4) 48 cm<sup>3</sup>

- 12 The solid below is made up of 1-cm cubes. How many more 1-cm cubes must be added to the solid to make it a cuboid measuring 4 cm by 3 cm by 4 cm?

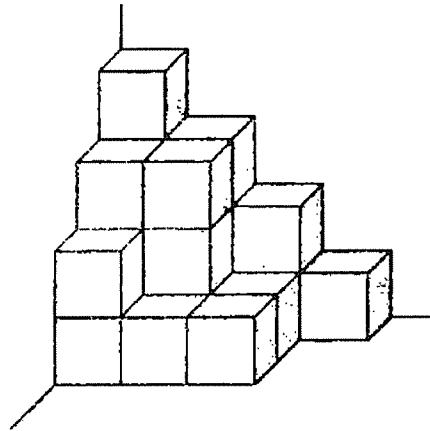

- (1) 27  
(2) 28  
(3) 29  
(4) 30



- 13 The table below shows the number of bicycles sold each month by a shop.

Month	Number of bicycles sold
January	53
February	150
March	124
April	76
May	99

Which of the following bar graphs best represents the information shown in the table?

(1)

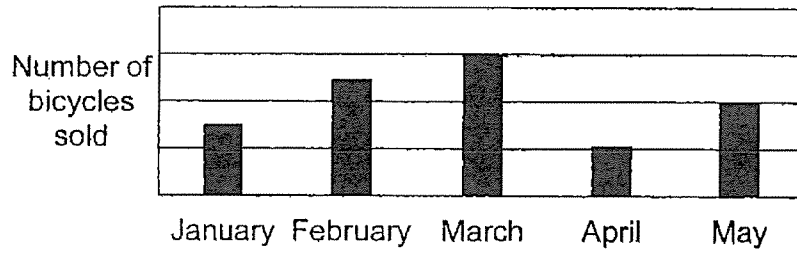

(2)

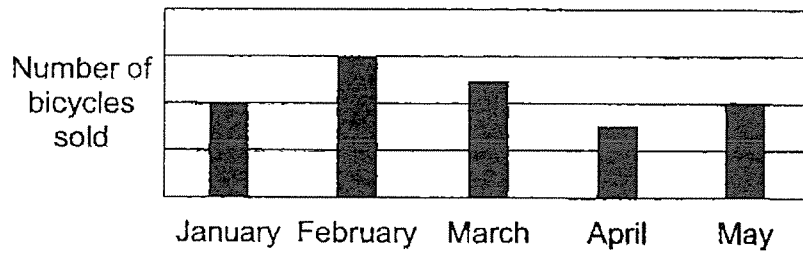

(3)

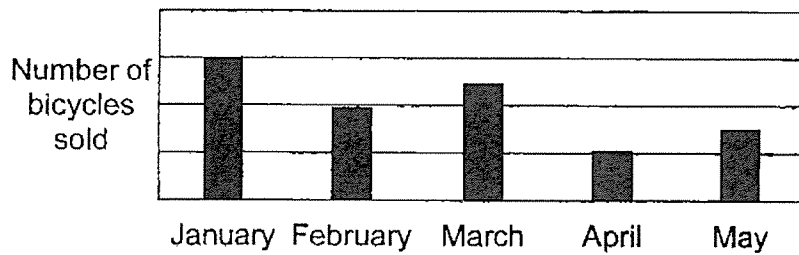

(4)

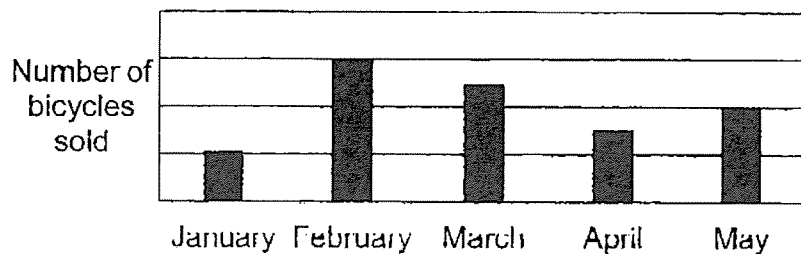

- 14 Sally had some apples.  $\frac{3}{5}$  of the apples were red. She then gave  $\frac{1}{2}$  of the red apples to her sister. What fraction of Sally's apples were given to her sister?

(1)  $\frac{1}{5}$

(2)  $\frac{5}{6}$

(3)  $\frac{1}{10}$

(4)  $\frac{3}{10}$

- 15 The first 15 numbers of a number pattern are given below.

9, 0, 8, 6, 9, 0, 8, 6, 9, 0, 8, 6, 9, 0, 8, ...  
1<sup>st</sup> 15<sup>th</sup>

What is the 274<sup>th</sup> number?

(1) 0

(2) 6

(3) 8

(4) 9



NANYANG PRIMARY SCHOOL

**TERM 1 WEIGHTED ASSESSMENT  
2023**

**PRIMARY 6**

**MATHEMATICS  
PAPER 1  
(BOOKLET B)**

Total Duration for Booklets A and B: 1 hour

**INSTRUCTIONS TO PUPILS**

1. Do not turn over this page until you are told to do so.
2. Follow all instructions carefully.
3. Answer all questions.
4. Write your answers in this booklet.
5. The use of calculators is **NOT** allowed.

Name: \_\_\_\_\_ (      )

Class: Primary 6 (      )

**Booklet B**

**/ 25**

Please sign and return the examination paper the next day. Any queries should be raised at the same time when returning paper.

Questions 16 to 20 carry 1 mark each. Write your answers in the spaces provided. For questions which require units, give your answers in the units stated. (5 marks)

---

16 Find the value of  $72 \div 8 - 2 \times 3 + 77$ .

Ans: \_\_\_\_\_

---

17 The breadth of a rectangle is  $\frac{5}{6}$  m and its area is  $2 \text{ m}^2$ . Find the length of the rectangle. Express your answer as a mixed number in its simplest form.

Ans: \_\_\_\_\_ m

---

- 18 The ratio of Shina's test marks to Kyle's test marks was 3 : 7. Shina scored 16 fewer marks than Kyle. How many marks did Kyle score?

Ans: \_\_\_\_\_

---

- 19 Round 199.99 to 1 decimal place.

Ans: \_\_\_\_\_

---

- 20 Mrs Pereira baked 400 tarts. 45% of the tarts she baked were egg tarts while the rest were chocolate tarts. How many chocolate tarts did Mrs Pereira bake?

Ans: \_\_\_\_\_

---

Questions 21 to 30 carry 2 marks each. Show your working clearly and write your answers in the spaces provided. For questions which require units, give your answers in the units stated. (20 marks)

---

21 75% of a number is 36. What is the number?

Ans: \_\_\_\_\_

---

22 Derinda had 25 m of ribbon. She used it to make as many flowers as possible. She used  $\frac{2}{3}$  m of ribbon to make each flower. How many metres of the ribbon were left?

Ans: \_\_\_\_\_ m

---

- 23 Brenda had 6 ℓ of orange juice. She drank  $\frac{1}{2}$  of it in the morning and gave  $\frac{1}{4}$  ℓ of it to her brother. How much orange juice did she have left in the end?

Ans: \_\_\_\_\_ ℓ

---

- 24 In a camp, the number of children is  $\frac{3}{8}$  of the number of adults.  $\frac{2}{9}$  of the children are boys and there is an equal number of men and women. What is the ratio of the number of girls to the number of women?

Ans: \_\_\_\_\_

---

- 25 Clarence, Amir and Jun Wei received some stickers. The ratio of the number of stickers that Clarence received to the number of stickers Amir received was 4 : 9. The ratio of the number of stickers Jun Wei received to the number of stickers Amir received was 4 : 3. Clarence received 24 stickers. How many stickers did Jun Wei receive?

Ans: \_\_\_\_\_

---

- 26 The ratio of the number of sweets Rachel had to the number of sweets Euodia had was 2 : 3 at first. After Rachel bought 8 more sweets, the ratio of the number of sweets Rachel had to the number of sweets Euodia had became 5 : 6. How many sweets did Euodia have?

Ans: \_\_\_\_\_

---



- 27 Mr Tan had \$20 more than Mr Lee at first. After Mr Tan spent \$50 and Mr Lee spent half of his money, both of them had the same amount of money left. How much money did Mr Lee have at first?

Ans: \$ \_\_\_\_\_

---

- 28 Diane wanted to train for a marathon. She started by running 1.6 km in the first week. She increased her distance by 1.2 km every week from the previous week. Find the total distance that she ran in the first 5 weeks.

Ans: \_\_\_\_\_ km

---

- 29 A wire 210 cm long was cut into 2 pieces and bent to form a rectangle and a square. The length of the rectangle is 48.5 cm and its breadth is 38.5 cm. Find the length of one side of the square.

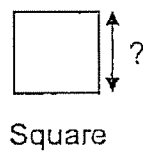
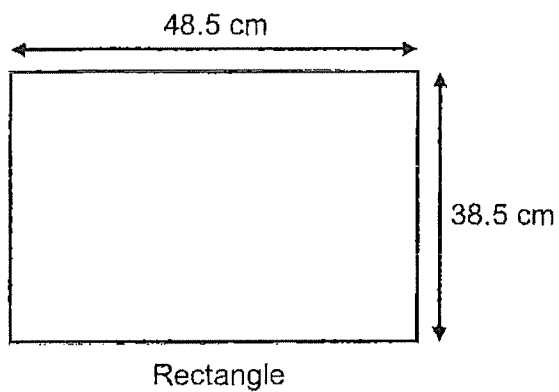

Ans: \_\_\_\_\_ cm

---

- 30 The table below shows the number of toys collected by Sunshine Centre in Year 2021 and Year 2022. Part of the table is covered by an ink blot. The number of soft toys collected and the total number of toys collected were both three-digit numbers.

Type of Toys	Year 2021	Year 2022
Wooden Toys	121	80
Electronic Toys	65	74
Soft Toys	18	200
Total number of toys	3	354

Each of the statements is either true, false or not possible to tell from the information given. For each statement, put a tick (✓) to indicate your answer.

Statement	True	False	Not possible to tell
In Year 2021, more than 50% of the toys collected were soft toys.			
In Year 2021, 20% of the toys collected were electronic toys.			
In Year 2022, the number of wooden toys collected was 40% of the number of soft toys collected.			

---

End of Paper

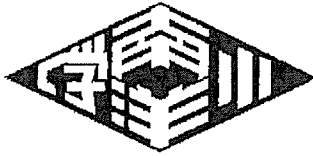

NANYANG PRIMARY SCHOOL

**TERM 1 WEIGHTED ASSESSMENT  
2023**

**PRIMARY 6**

**MATHEMATICS  
PAPER 2**

Duration: 1 hour 30 minutes

**INSTRUCTIONS TO PUPILS**

1. Do not turn over this page until you are told to do so.
2. Follow all instructions carefully.
3. Answer all questions.
4. Write your answers in this booklet.
5. The use of an approved calculator is allowed.

Name: \_\_\_\_\_ (       )

Class: Primary 6 (       )

Parent's Signature: \_\_\_\_\_

<b>Booklet A</b>	<b>/ 20</b>
<b>Booklet B</b>	<b>/ 25</b>
<b>Paper 2</b>	<b>/ 55</b>
<b>Total</b>	<b>/ 100</b>

Please sign and return the examination paper the next day. Any queries should be raised at the same time when returning paper.

Questions 1 to 5 carry 2 marks each. Show your working clearly and write your answers in the spaces provided. For questions which require units, give your answers in the units stated. (10 marks)

---

- 1 Jasper ran  $6\frac{1}{10}$  km. Irfan ran  $2\frac{7}{16}$  km more than Jasper. How far did they run altogether?

Ans: \_\_\_\_\_ km

---

- 2 The mass of each sack of rice is  $4\frac{1}{5}$  kg. Find the total mass of 45 such sacks of rice.

Ans: \_\_\_\_\_ kg

---

- 3 Joy had a meal that cost \$32.50 before GST at a restaurant. What was the cost of her meal after adding 8% GST?

Ans: \$ \_\_\_\_\_

---

- 4 Danny's scores for 5 games are shown in the table below.

Game	1 <sup>st</sup>	2 <sup>nd</sup>	3 <sup>rd</sup>	4 <sup>th</sup>	5 <sup>th</sup>
Score	8	0	7	16	9

Find his average score.

Ans: \_\_\_\_\_

---

- 5 Siti has the exact amount of money to buy 84 bottled drinks or 126 canned drinks. She has already spent some of the money to buy 39 canned drinks and 42 bottled drinks. How many more bottled drinks can she buy with the remaining money?

Ans: \_\_\_\_\_

---

For questions 6 to 17, show your working clearly and write your answers in the spaces provided. The number of marks available is shown in brackets [ ] at the end of each question or part-question. (45 marks)

---

- 6 Miss Wong bought two identical suitcases at a year-end sale. The two suitcases cost \$174 after discount. Find the price of one such suitcase before discount.



Ans: \_\_\_\_\_ [3]

---

- 7 Mr Mohammad took a taxi from home to his office.  
His taxi fare was based on the charges shown below.

First 1 kilometre or less	\$4.30
Every additional 400 m or less	\$0.24
Every 45 seconds of <u>waiting or less</u>	\$0.24

The taxi stopped once at a traffic light and travelled a total distance of 7 km to reach his office. Mr Mohammad paid \$9.10. What was the longest possible duration the taxi stopped at the traffic light?

Ans: \_\_\_\_\_ [3]

---



- 8 A rectangular tank measuring 32.5 cm by 22.5 cm by 18 cm was  $\frac{5}{9}$ -filled with water as shown below. When Kamala poured 7 litres of water into the tank, some water overflowed. Find the volume of water that overflowed. Give your answer in litres.

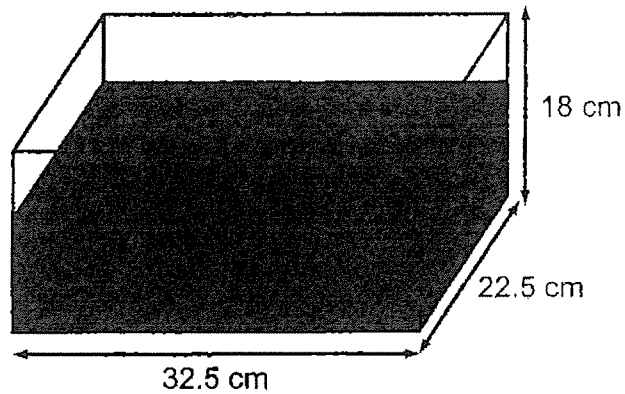

Ans: \_\_\_\_\_ [3]

---

- 9 Amrit had some sugar at first. He used 275 g of sugar to bake some muffins and  $\frac{3}{5}$  of the remaining sugar to bake some cookies. In the end, he had  $\frac{1}{8}$  of the sugar left. How much sugar did he have at first?

Ans: \_\_\_\_\_ [3]

---

- 10 In a class of 42 children, the average mass of the children was 37.5 kg. The average mass of the girls in the class was 36.7 kg. The average mass of the boys in the class was 38.8 kg. How many more girls than boys were there in the class?

Ans: \_\_\_\_\_ [3]

---

- 11 A group of children is put into 2 halls, hall A and hall B. The ratio of the number of children in hall A to the number of children in hall B is 3 : 8. In hall A, the ratio of the number of boys to the number of girls is 5 : 2. There are 18 girls in hall A. Find the total number of children in both halls.

Ans: \_\_\_\_\_ [3]

---

- 12 In the figure below, ABCD is a trapezium. APB, DQC, RCS and PQR are straight lines. APB is parallel to DQC and AD is parallel to PQR.  $\angle BCS = 50^\circ$ ,  $\angle BCQ = 90^\circ$  and  $\angle QRC = 95^\circ$ .

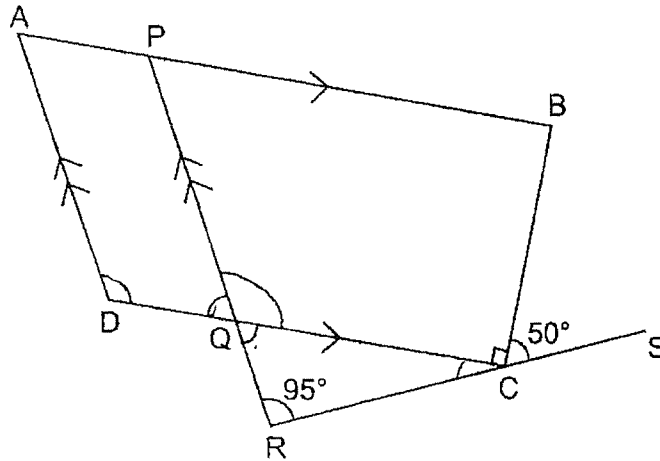

(a) Find  $\angle DQP$ .

Ans: (a) \_\_\_\_\_ [2]

(b) Find  $\angle ADQ$ .

Ans: (b) \_\_\_\_\_ [2]

- 13 Ashraf had some money at first. He spent 15% of it on food and \$810 on a new laptop. He then gave 20% of the remainder to his brother. In the end, he had \$304 left.

(a) How much money did Ashraf give to his brother?

Ans: (a) \_\_\_\_\_ [2]

(b) How much money did Ashraf have at first?

Ans: (b) \_\_\_\_\_ [3]

---

- 14 Susan had 117 beads and marbles altogether. The beads and marbles were either white or black. 20% of the beads and 50% of the marbles were white. There were as many black beads as black marbles.

- (a) In the statement below, circle the phrase 'more than', 'fewer than' or 'the same as' that correctly describes the comparison between the number of beads and marbles Susan had.

The number of beads Susan had was  
( more than / fewer than / the same as )  
the number of marbles she had.

- (b) How many beads did Susan have?

Ans: (b) \_\_\_\_\_ [3]

- 15 Christopher and Helen had 1044 erasers altogether at first. Christopher gave  $\frac{4}{5}$  of his erasers to his brother. Helen gave  $\frac{5}{8}$  of her erasers to her sister. In the end, Helen had 150 erasers more than Christopher. How many erasers did Christopher have at first?

Ans: \_\_\_\_\_ [4]

---



- 16 The figure below is made up of 2 squares, ABCD and DEFG. X is a point on GD and Y is a point on DE.  $BC = 7\text{ cm}$ ,  $FE = 6\text{ cm}$  and  $XD = DY = YE$ .

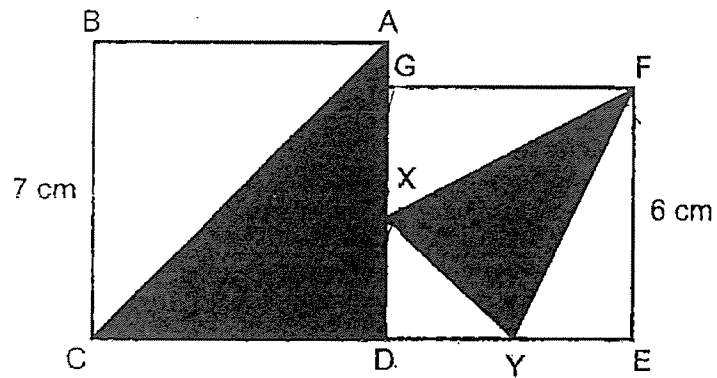

- (a) Find the total area of the shaded parts.

Ans: (a) \_\_\_\_\_ [3]

- (b) What fraction of the figure is unshaded?

Ans: (b) \_\_\_\_\_ [2]

- 17 The table below shows the number of clips in different coloured containers.

Colour of container	Number of clips in each container
White	30
Blue	50
Green	60

- (a) Gwen has a total of 10 white containers and green containers. What is the smallest possible difference between the total number of clips in Gwen's white containers and the total number of clips in her green containers?

Ans: (a) \_\_\_\_\_ [2]

- (b) Clement has some white containers and some blue containers. The ratio of the total number of clips in Clement's white containers to the total number of clips in his blue containers is 3 : 2. Express the number of his blue containers as a fraction of the total number of his containers.

Ans: (b) \_\_\_\_\_ [3]

---

End of Paper



NANYANG PRIMARY SCHOOL

TERM 1 WEIGHTED ASSESSMENT  
2023

PRIMARY 6

MATHEMATICS  
PAPER 1  
(BOOKLET A)

Total Duration for Booklets A and B: 1 hour

Additional materials: Optical Answer Sheet (OAS)

INSTRUCTIONS TO PUPILS

1. Do not turn over this page until you are told to do so.
2. Follow all instructions carefully.
3. Answer all questions.
4. Shade your answers in the Optical Answer Sheet (OAS) provided.
5. The use of calculators is **NOT** allowed.

Name: \_\_\_\_\_ ( )

Primary 6 ( )

Questions 1 to 10 carry 1 mark each. Questions 11 to 15 carry 2 marks each. For each question, four options are given. One of them is the correct answer. Make your choice (1, 2, 3 or 4) and shade your answer on the Optical Answer Sheet. (20 marks)

1 Janice is  $\frac{5}{7}$  as tall as Xiao Ming. What is the ratio of Xiao Ming's height to Janice's height?

xiao ming : Janice  
7 : 5

- (1) 5 : 7
- (2) 7 : 5
- (3) 5 : 12
- (4) 7 : 12

(2)

2 A pail contains 28 l of water. A tank contains 800 times as much water as the pail. How many litres of water are there in the tank?

- (1) 16 400 l
- (2) 22 400 l
- (3) 64 400 l
- (4) 224 000 l

$28 \times 800 = 28 \times 8 \times 100$   
 $= 224 \times 100$   
 $= 22 400$

(2)

$\begin{array}{r} 28 \\ \times 8 \\ \hline 224 \end{array}$

3 What is the value of  $\frac{2}{3} + \frac{1}{5}$ ?

- (1)  $\frac{3}{8}$
- (2)  $\frac{3}{15}$
- (3)  $\frac{2}{16}$
- (4)  $\frac{13}{15}$

$\frac{10}{15} + \frac{3}{15}$   
 $= \frac{13}{15}$

(4)

5 What is the value of  $\frac{3}{7} \times \frac{5}{2}$ ?

- (1)  $\frac{8}{9}$
- (2)  $\frac{15}{14}$
- (3)  $\frac{15}{9}$
- (4)  $\frac{8}{35}$

$\frac{3}{7} \times \frac{5}{2} = \frac{15}{14}$

(2)

4 In the number line below, what is the value of X?

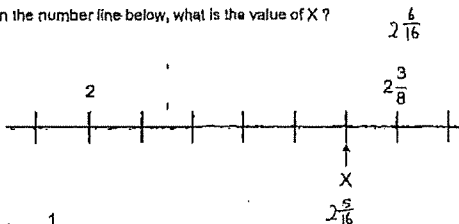

- (1)  $2\frac{1}{4}$
- (2)  $2\frac{3}{10}$
- (3)  $2\frac{5}{16}$
- (4)  $2\frac{1}{2}$

(3)

6  $\frac{3}{4}$  of a pizza was shared equally among 5 people. What fraction of the pizza did each person receive?

- (1)  $\frac{3}{20}$
- (2)  $\frac{4}{15}$
- (3)  $\frac{20}{3}$
- (4)  $\frac{7}{45}$

$\frac{3}{4} \div \frac{5}{1}$   
K r F  
 $= \frac{3}{4} \times \frac{1}{5}$   
 $= \frac{3}{20}$

(1)

7 Express 10.01 kg in kilograms and grams.

$$0.01 \times 1000 = 10$$

- (1) 1 kg 1 g
- (2) 10 kg 1 g
- (3) 10 kg 10 g
- (4) 100 kg 10 g

(3)

8 <sup>90</sup> Ninety identical pencils cost \$57.60. What is the cost of one such pencil?

- (1) \$0.54
- (2) \$0.64
- (3) \$0.74
- (4) \$6.40

$$\begin{aligned} \$57.60 \div 90 &= \$\frac{57.60}{9} \div 10 \\ &= \$6.40 \div 10 \end{aligned}$$

$$\begin{array}{r} 6.40 \\ 9 \overline{) 57.60} \\ \underline{-54} \phantom{0} \\ 36 \\ \underline{-36} \\ 0 \end{array}$$

(2)

9 Sathya had 250 fruits. 50 of them were papayas, 110 of them were mangoes and the rest were pears. What percentage of her fruits were pears?

- (1) 20%
- (2) 36%
- (3) 44%
- (4) 64%

$$\begin{aligned} \text{Pears} &\rightarrow 250 - 50 - 110 \\ &= 200 - 110 \\ &= 90 \end{aligned}$$

$$\begin{aligned} \frac{90}{250} &= \frac{9}{25} \\ &= \frac{36}{100} \\ &= 36\% \end{aligned}$$

(2)

12 The solid below is made up of 1 cm cubes. How many more 1-cm cubes must be added to the solid to make it a cuboid measuring 4 cm by 3 cm by 4 cm?

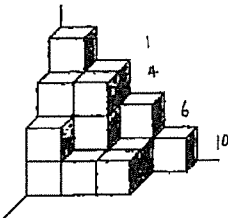

- (1) 27
- (2) 28
- (3) 29
- (4) 30

$$\begin{aligned} 4 \times 3 \times 4 &= 12 \times 4 \\ &= 48 \end{aligned}$$

$$1 + 4 + 6 + 10 = 21$$

$$48 - 21 = 27$$

(1)

10 Which one of the following is likely to be the mass of a honeydew sold in a supermarket?



- (1) 2.5 g
- (2) 25 g
- (3) 2.5 kg
- (4) 250 kg

(3)

11 The length, breadth and height of a box are in the ratio 3 : 2 : 1 respectively. The length of the box is 6 cm. Find the volume of the box.

- (1) 12 cm<sup>3</sup>
- (2) 18 cm<sup>3</sup>
- (3) 36 cm<sup>3</sup>
- (4) 48 cm<sup>3</sup>

$$3 \text{ units} = 6 \text{ cm}$$

$$1 \text{ unit} = 6 \div 3 = 2$$

$$2 \text{ units} = 2 \times 2 = 4$$

$$\text{Volume} = \text{Length} \times \text{Breadth} \times \text{Height}$$

$$= 6 \times 4 \times 2$$

$$= 24 \times 2$$

$$= 48$$

(4)

13 The table below shows the number of bicycles sold each month by a shop.

Month	Number of bicycles sold
January	53
February	150
March	124
April	76
May	88

Which of the following bar graphs best represents the information shown in the table?

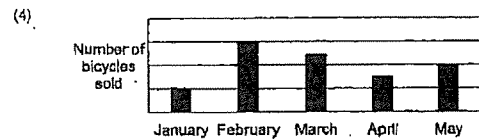
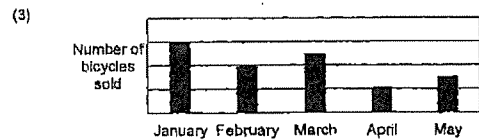
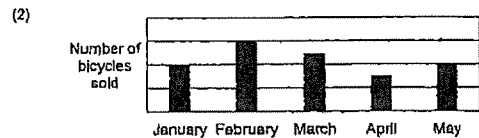
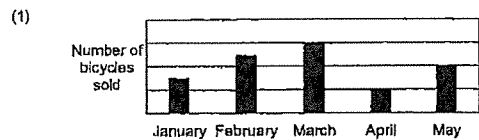

(4)

- 14 Sally had some apples.  $\frac{3}{5}$  of the apples were red. She then gave  $\frac{1}{2}$  of the red apples to her sister. What fraction of Sally's apples were given to her sister?

- (1)  $\frac{1}{5}$   
 (2)  $\frac{6}{5}$   
 (3)  $\frac{1}{10}$   
 (4)  $\frac{3}{10}$

$$\frac{3}{5} \times \frac{1}{2} = \frac{3}{10}$$

(4)

- 15 The first 15 numbers of a number pattern are given below.

$\underbrace{0, 0, 8, 0, 9, 0, 8, 6, 9, 0, 8, 6, 9, 0, 8, \dots}_{1^{\text{st}} \quad \quad \quad 15^{\text{th}}}$

What is the 274<sup>th</sup> number?

- (1) 0  
 (2) 6  
 (3) 8  
 (4) 9

$$274 \div 4 = 68R2$$

$$\begin{array}{r} 68 \\ 4 \overline{)274} \\ \underline{-24} \phantom{0} \\ 34 \\ \underline{-32} \\ 2 \end{array}$$

(1)



NANYANG PRIMARY SCHOOL

TERM 1 WEIGHTED ASSESSMENT  
2023

PRIMARY 6

MATHEMATICS  
PAPER 1  
(BOOKLET B)

Total Duration for Booklets A and B: 1 hour

INSTRUCTIONS TO PUPILS

1. Do not turn over this page until you are told to do so.
2. Follow all instructions carefully.
3. Answer all questions.
4. Write your answers in this booklet.
5. The use of calculators is **NOT** allowed.

Name: \_\_\_\_\_ ( )

Class: Primary 6 ( )

Booklet B	/ 25
-----------	------

Please sign and return the examination paper the next day. Any queries should be raised at the same time when returning paper.

Questions 16 to 20 carry 1 mark each. Write your answers in the spaces provided. For questions which require units, give your answers in the units stated. (5 marks)

- 16 Find the value of  $72 \div 8 - 2 \times 3 + 77$ .

$$\begin{aligned} & 72 \div 8 - 2 \times 3 + 77 \\ &= 9 - 2 \times 3 + 77 \\ &= 9 - 6 + 77 \\ &= 3 + 77 \\ &= 80 \text{ (ans)} \end{aligned}$$

Ans: 80

- 17 The breadth of a rectangle is  $\frac{5}{6}$  m and its area is 2 m<sup>2</sup>. Find the length of the rectangle. Express your answer as a mixed number in its simplest form.

$$\begin{aligned} \text{Length} &= 2 \div \frac{5}{6} \\ &= \frac{2}{1} \times \frac{6}{5} \\ &= \frac{12}{5} \\ &= 2\frac{2}{5} \text{ m (ans)} \end{aligned}$$

Ans: 2 $\frac{2}{5}$  m

- 18 The ratio of Shina's test marks to Kyle's test marks was 3 : 7. Shina scored 16 fewer marks than Kyle. How many marks did Kyle score?

$$\begin{aligned} 7 - 3 &= 4 \\ 4 \text{ units} &= 16 \\ 1 \text{ unit} &= 16 \div 4 \\ &= 4 \\ 7 \text{ units} &= 4 \times 7 \\ &= 28 \text{ (ans)} \end{aligned}$$

Ans: 28

- 19 Round 199.99 to 1 decimal place.

$$199.\underline{9}9 \approx 200.0 \text{ (ans)}$$

Ans: 200.0

- 20 Mrs Pereira baked 400 tarts. 45% of the tarts she baked were egg tarts while the rest were chocolate tarts. How many chocolate tarts did Mrs Pereira bake?

$$\begin{aligned} 100\% - 45\% &= 55\% \\ \frac{55}{100} \times \frac{400}{1} \\ &= 55 \times 4 \\ &= 220 \text{ (ans)} \end{aligned}$$

OR

$$\begin{aligned} \frac{45}{100} \times \frac{400}{1} &= 45 \times 4 \\ &= 180 \\ 400 - 180 &= 220 \text{ (ans)} \end{aligned}$$

Ans: 220

Questions 21 to 30 carry 2 marks each. Show your working clearly and write your answers in the spaces provided. For questions which require units, give your answers in the units stated. (20 marks)

21 75% of a number is 36. What is the number?

$$\begin{aligned} \div 3 \downarrow & 75\% \rightarrow 36 \\ & 25\% \rightarrow 36 \div 3 \\ & = 12 \\ \div 4 \downarrow & 100\% \rightarrow 12 \times 4 \\ & = 48 \text{ (ans)} \end{aligned}$$

OR

$$\begin{aligned} 75\% &= \frac{3}{4} \\ \frac{3}{4} &\rightarrow 36 \\ \frac{1}{4} &\rightarrow 36 \div 3 \\ &= 12 \\ \frac{4}{4} &\rightarrow 12 \times 4 \\ &= 48 \text{ (ans)} \end{aligned}$$

Ans: 48

22 Derinda had 25 m of ribbon. She used it to make as many flowers as possible. She used  $\frac{2}{3}$  m of ribbon to make each flower. How many metres of the ribbon were left?

$$\begin{array}{r} 37 \\ 2 \overline{) 75} \\ \underline{-6} \phantom{0} \\ 15 \\ \underline{-14} \\ 1 \end{array}$$

$$\begin{aligned} 25 \div \frac{2}{3} &= \frac{25}{1} \times \frac{3}{2} \\ &= \frac{75}{2} \\ &= 37\frac{1}{2} \end{aligned}$$

$$\frac{1}{2} \times \frac{2}{3} = \frac{1}{3} \text{ m (ans)}$$

Ans:  $\frac{1}{3}$  m

23 Clarence, Amir and Jun Wei received some stickers. The ratio of the number of stickers that Clarence received to the number of stickers Amir received was 4:9. The ratio of the number of stickers Jun Wei received to the number of stickers Amir received was 4:3. Clarence received 24 stickers. How many stickers did Jun Wei receive?

$$\begin{array}{l} \downarrow \\ \text{Clarence : Amir} \\ \underline{4 : 9} \end{array} \quad \begin{array}{l} \downarrow \\ \text{Jun Wei : Amir} \\ \underline{4 : 3} \\ \underline{12 : 9} \end{array}$$

$$\begin{aligned} 4 \text{ units} &= 24 \\ 1 \text{ unit} &= 24 \div 4 \\ &= 6 \end{aligned}$$

$$12 \text{ units} = 6 \times 12$$

$$= 72 \text{ (ans)} \quad \text{Ans: } \underline{72}$$

24 The ratio of the number of sweets Rachel had to the number of sweets Euodia had was 2:3 at first. After Rachel bought 8 more sweets, the ratio of the number of sweets Rachel had to the number of sweets Euodia had became 5:6. How many sweets did Euodia have?

Euodia constant

$$\begin{array}{l} \text{At first,} \\ \text{Rachel : Euodia} \\ \underline{2 : 3} \\ \underline{4 : 6} \end{array} \quad \begin{array}{l} \text{End,} \\ \text{Rachel : Euodia} \\ \underline{5 : 6} \end{array}$$

$$5 - 4 = 1$$

$$1 \text{ unit} = 8$$

$$6 \text{ units} = 8 \times 6$$

$$= 48 \text{ (ans)}$$

Ans: 48

25 Brenda had 6 l of orange juice. She drank  $\frac{1}{2}$  of it in the morning and gave  $\frac{1}{4}$  l of it to her brother. How much orange juice did she have left in the end?

$$\begin{aligned} \text{morning} &\rightarrow \frac{1}{2} \times \frac{6}{1} \\ &= 3 \text{ l} \end{aligned}$$

$$\text{Left} \rightarrow 6 - 3 = 3$$

$$= 3 - \frac{1}{4}$$

$$= 2\frac{3}{4}$$

$$= 2\frac{3}{4} \text{ l (ans)}$$

Ans:  $2\frac{3}{4}$  l

26 In a camp, the number of children is  $\frac{3}{8}$  of the number of adults.  $\frac{2}{9}$  of the children are boys and there is an equal number of men and women.

What is the ratio of the number of girls to the number of women?

$$\begin{array}{l} \downarrow \\ \text{Children : Adult} \\ 3 : 8 \\ \underline{9 : 24} \end{array} \quad \begin{array}{l} \downarrow \\ \text{boys : girls : children} \\ 2 : 7 : 9 \end{array}$$

$$24 \div 2 = 12$$

Girls : Women

$$7 : 12 \text{ (ans)}$$

Ans: 7:12

27 Mr Tan had \$20 more than Mr Lee at first. After Mr Tan spent \$50 and Mr Lee spent half of his money, both of them had the same amount of money left. How much money did Mr Lee have at first?

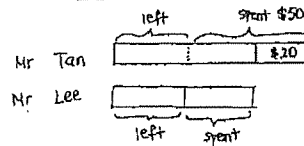

$$\begin{aligned} 1 \text{ unit} &= \$50 - \$20 \\ &= \$30 \end{aligned}$$

$$2 \text{ units} = \$30 \times 2$$

$$= \$60 \text{ (ans)}$$

Ans: \$ 60

28 Diane wanted to train for a marathon. She started by running 1.6 km in the first week. She increased her distance by 1.2 km every week from the previous week. Find the total distance that she ran in the first 5 weeks.

$$\begin{array}{l} 1\text{st} \quad 1.6 \\ 2\text{nd} \quad 1.6 + 1.2 \\ 3\text{rd} \quad 1.6 + 1.2 + 1.2 \\ 4\text{th} \quad 1.6 + 1.2 + 1.2 + 1.2 \\ 5\text{th} \quad 1.6 + 1.2 + 1.2 + 1.2 + 1.2 \end{array} \quad \left. \vphantom{\begin{array}{l} 1\text{st} \\ 2\text{nd} \\ 3\text{rd} \\ 4\text{th} \\ 5\text{th} \end{array}} \right\} ?$$

$$1.6 \times 5 = 8$$

$$1.2 \times 10 = 12$$

$$8 + 12 = 20 \text{ (ans)}$$

Ans: 20 km

- 29 A wire 210 cm long was cut into 2 pieces and bent to form a rectangle and a square. The length of the rectangle is 48.5 cm and its breadth is 38.5 cm. Find the length of one side of the square.

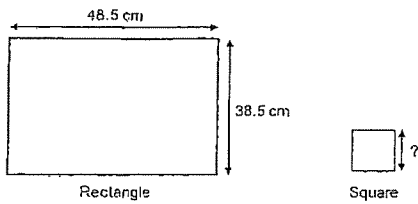

$$\begin{array}{r} 48.5 \\ + 38.5 \\ \hline 87.0 \end{array}$$

$$\begin{aligned} \text{Perimeter of rectangle} &= (48.5 + 38.5) \times 2 \\ &= 87 \times 2 \\ &= 174 \end{aligned}$$

$$\begin{array}{r} 87 \\ \times 2 \\ \hline 174 \end{array}$$

$$210 - 174 = 36$$

$$36 \div 4 = 9 \text{ cm (ans)}$$

$$\begin{array}{r} 10 \\ 1210 \\ - 174 \\ \hline 36 \end{array}$$

Ans: 9 cm

- 30 The table below shows the number of toys collected by Sunshine Centre in Year 2021 and Year 2022. Part of the table is covered by an ink blot. The number of soft toys collected and the total number of toys collected were both three-digit numbers.

Type of Toys	Year 2021	Year 2022
Wooden Toys	121	80
Electronic Toys	65	74
Soft Toys	180	200
Total number of toys	366	354

Each of the statements is either true, false or not possible to tell from the information given. For each statement, put a tick (✓) to indicate your answer.

Statement	True	False	Not possible to tell
In Year 2021, more than 50% of the toys collected were soft toys.			✓
In Year 2021, 20% of the toys collected were electronic toys.		✓	
In Year 2022, the number of wooden toys collected was 40% of the number of soft toys collected.	✓		

$$121 + 65 = 186$$

$$\begin{aligned} 20\% &\rightarrow 65 \\ 10\% &\rightarrow 65 \div 2 \\ &= 32.5 \\ 100\% &\rightarrow 32.5 \times 10 \\ &= 325 \end{aligned}$$

$$121 + 65 + 180$$

$$= 186 + 180$$

$$= 366$$

Total toys in 2021 is at least 366

$$\frac{80}{200} = \frac{40}{100}$$

$$= 40\%$$

End of Paper



NANYANG PRIMARY SCHOOL  
TERM 1 WEIGHTED ASSESSMENT  
2023

PRIMARY 6  
MATHEMATICS  
PAPER 2

Duration: 1 hour 30 minutes

INSTRUCTIONS TO PUPILS

- Do not turn over this page until you are told to do so.
- Follow all instructions carefully.
- Answer all questions.
- Write your answers in this booklet.
- The use of an approved calculator is allowed.

Name: \_\_\_\_\_ ( )

Class: Primary 6 ( )

Parent's Signature: \_\_\_\_\_

Booklet A	/ 20
Booklet B	/ 25
Paper 2	/ 55
Total	/ 100

Please sign and return the examination paper the next day. Any queries should be raised at the same time when returning paper.

Questions 1 to 5 carry 2 marks each. Show your working clearly and write your answers in the spaces provided. For questions which require units, give your answers in the units stated. (10 marks)

- 1 Jasper ran  $6\frac{1}{10}$  km. Ifran ran  $2\frac{7}{18}$  km more than Jasper. How far did they run altogether?

$$\begin{aligned} \text{Ifran} &\rightarrow 2\frac{7}{18} + 6\frac{1}{10} \\ &= 8\frac{43}{90} \end{aligned}$$

$$8\frac{43}{90} + 6\frac{1}{10} = 14\frac{51}{90} \text{ (ans)}$$

Ans: 14  $\frac{51}{90}$  km

- 2 The mass of each sack of rice is  $4\frac{1}{5}$  kg. Find the total mass of 45 such sacks of rice.

$$4\frac{1}{5} \times 45 = 189 \text{ (ans)}$$

Ans: 189 kg

- 3 Joy had a meal that cost \$32.50 before GST at a restaurant. What was the cost of her meal after adding 8% GST?

$$120\% + 8\% = 128\%$$

$$\frac{128}{100} \times \$32.50 = \$41.60 \text{ (ans)}$$

Ans: \$ 41.60

- 4 Danny's scores for 5 games are shown in the table below.

Game	1 <sup>st</sup>	2 <sup>nd</sup>	3 <sup>rd</sup>	4 <sup>th</sup>	5 <sup>th</sup>
Score	8	0	7	16	9

Find his average score.

$$\frac{8 + 0 + 7 + 16 + 9}{5} = \frac{40}{5}$$

$$= 8 \text{ (ans)}$$

Ans: 8

- 5 Siti has the exact amount of money to buy 84 bottled drinks or 126 canned drinks. She has already spent some of the money to buy 39 canned drinks and 42 bottled drinks. How many more bottled drinks can she buy with the remaining money?

$$84 \text{ bottled} \rightarrow 126 \text{ canned}$$

$$1 \text{ bottled} \rightarrow \frac{126}{84} \text{ canned}$$

$$= 1.5$$

$$39 \div 1.5 = 26$$

$$26 \text{ bottled} \rightarrow 39 \text{ canned}$$

$$84 - 26 - 42 = 16 \text{ (ans)}$$

Ans: 16

- 7 Mr Mohammad took a taxi from home to his office. His taxi fare was based on the charges shown below.

First 1 kilometre or less	\$4.30
Every additional 400 m or less	\$0.24
Every 45 seconds of waiting or less	\$0.24

The taxi stopped once at a traffic light and travelled a total distance of 7 km to reach his office. Mr Mohammad paid \$9.10. What was the longest possible duration the taxi stopped at the traffic light?

$$7 - 1 = 6$$

$$6 \text{ km} = 6000 \text{ m}$$

$$6000 \div 400 = 15$$

$$15 \times \$0.24 = \$3.60$$

$$\$3.60 + \$4.30 = \$7.90$$

$$\$9.10 - \$7.90 = \$1.20$$

$$\$1.20 \div \$0.24 = 5$$

$$5 \times 45 = 225 \text{ s (ans)}$$

Ans: 225 s (3)

For questions 8 to 17, show your working clearly and write your answers in the spaces provided. The number of marks available is shown in brackets [ ] at the end of each question or part-question. (45 marks)

- 6 Miss Wong bought two identical suitcases at a year-end sale. The two suitcases cost \$174 after discount. Find the price of one such suitcase before discount.

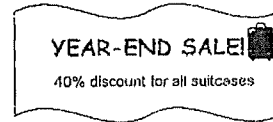

$$1 \text{ suitcase after discount} \rightarrow \$174 \div 2$$

$$= \$87$$

$$100\% - 40\% = 60\%$$

$$\div 60 \rightarrow \$87 \rightarrow \$27$$

$$10\% \rightarrow \$27 \div 6$$

$$= \$4.50$$

$$\times 100 \rightarrow \$4.50 \times 10$$

$$= \$45 \text{ (ans)}$$

Ans: \$45 (3)

- 8 A rectangular tank measuring 32.5 cm by 22.5 cm by 18 cm was  $\frac{5}{8}$ -filled with water as shown below. When Kamala poured 7 litres of water into the tank, some water overflowed. Find the volume of water that overflowed. Give your answer in litres.

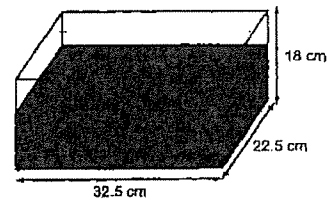

$$\text{Volume of tank} = 32.5 \times 22.5 \times 18$$

$$= 13162.5$$

$$1 - \frac{5}{8} = \frac{3}{8}$$

$$\frac{3}{8} \times 13162.5 = 5850$$

$$7000 - 5850 = 1150$$

$$1150 \text{ cm}^3 = 1.15 \text{ l (ans)}$$

Ans: 1.15 l (3)



- 9 Aunt had some sugar at first. He used  $275\text{ g}$  of sugar to bake some muffins and  $\frac{3}{5}$  of the remaining sugar to bake some cookies. In the end, he had  $\frac{1}{8}$  of the sugar left. How much sugar did he have at first?

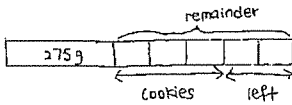

$$\frac{1}{8} \text{ of sugar} \rightarrow 2 \text{ units}$$

$$\frac{3}{5} \text{ of sugar} \rightarrow 3 \times 8$$

$$= 16 \text{ units}$$

$$16 - 5 = 11$$

$$11 \text{ units} = 275$$

$$1 \text{ unit} = 275 \div 11$$

$$= 25$$

$$16 \text{ units} = 25 \times 16$$

$$= 400 \text{ g (ans)}$$

Ans: 400 g [3]

- 10 In a class of 42 children, the average mass of the children was  $37.5\text{ kg}$ . The average mass of the girls in the class was  $36.7\text{ kg}$ . The average mass of the boys in the class was  $38.8\text{ kg}$ . How many more girls than boys were there in the class?

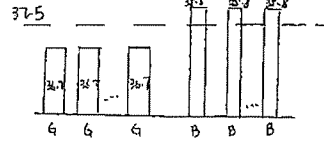

$$37.5 - 36.7 = 0.8$$

↑  
need to top up  
0.8 kg per girl

$$38.8 - 37.5 = 1.3$$

↑  
need to take  
away 1.3 kg  
per boy

$$13 + 8 = 21$$

$$42 \div 21 = 2$$

$$13 \times 2 = 26 \rightarrow \text{number of girls}$$

$$8 \times 2 = 16 \rightarrow \text{number of boys}$$

$$26 - 16 = 10 \text{ (ans)}$$

or  
Supposition method

$$42 \times 37.5 = 1575$$

Suppose all 42 are girls

$$42 \times 36.7 = 1541.4$$

$$1575 - 1541.4 = 33.6$$

$$38.8 - 36.7 = 2.10$$

$$33.6 \div 2.10 = 16 \rightarrow \text{ex}$$

$$42 - 16 = 26 \rightarrow \text{girls}$$

$$26 - 16 = 10 \text{ (ans)}$$

Ans: 10 [3]

- 11 A group of children is put into 2 halls, hall A and hall B. The ratio of the number of children in hall A to the number of children in hall B is 3 : 8. In hall A, the ratio of the number of boys to the number of girls is 5 : 2. There are 18 girls in hall A. Find the total number of children in both halls.

In A,

A : B	Boys : Girls : total
3 : 8	5 : 2 : 7
<u>21 : 56</u>	<u>15 : 6 : 21</u>

$$6 \text{ units} = 18$$

$$1 \text{ unit} = 18 \div 6$$

$$= 3$$

$$21 + 56 = 77$$

$$77 \text{ units} = 3 \times 77$$

$$= 231 \text{ (ans)}$$

Ans: 231 [3]

- 12 In the figure below, ABCD is a trapezium. APB, DQC, RCS and PQR are straight lines. APB is parallel to DQC and AD is parallel to PQR.  $\angle BCS = 50^\circ$ ,  $\angle BCQ = 90^\circ$  and  $\angle QRC = 95^\circ$ .

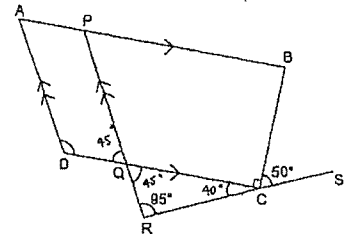

- (a) Find  $\angle DQP$ .

$$\angle RCQ = 180^\circ - 90^\circ - 50^\circ$$

$$= 40^\circ$$

$$\angle RQC = 180^\circ - 95^\circ - 40^\circ$$

$$= 45^\circ \text{ (ans)}$$

$$= \angle DQP$$

Ans: (a) 45° [2]

- (b) Find  $\angle ADQ$ .

$$\angle ADQ = 180^\circ - 45^\circ$$

$$= 135^\circ \text{ (ans)}$$

Ans: (b) 135° [2]

- 13 Ashraf had some money at first. He spent 15% of it on food and \$810 on a new laptop. He then gave 20% of the remainder to his brother. In the end, he had \$304 left.

(a) How much money did Ashraf give to his brother?

$$100\% - 15\% = 85\%$$

$$85\% \text{ of remainder} \rightarrow \$304$$

$$\frac{1}{85} \left\{ \begin{array}{l} 20\% \text{ of remainder} \rightarrow \$304 \div 4 \\ = \$76 \text{ (ans)} \end{array} \right.$$

Ans: (a) \$76 [2]

(b) How much money did Ashraf have at first?

$$\text{remainder} \rightarrow \$76 \times 5$$

$$= \$380$$

$$100\% - 15\% = 85\%$$

$$85\% \rightarrow \$380 + \$810$$

$$= \$1190$$

$$1\% \rightarrow \$1190 \div 85$$

$$= \$14$$

$$100\% \rightarrow \$14 \times 100$$

$$= \$1400 \text{ (ans)}$$

Ans: (b) \$1400 [3]

10

- 15 Christopher and Helen had 1044 erasers altogether at first. Christopher gave  $\frac{4}{6}$  of his erasers to his brother. Helen gave  $\frac{5}{8}$  of her erasers to her sister. In the end, Helen had 150 erasers more than Christopher. How many erasers did Christopher have at first?

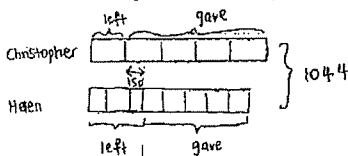

make them of the same unit

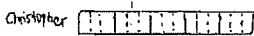

$$150 \div 3 = 50$$

$$3 \times 5 = 15 \text{ units} \rightarrow \text{Christopher}$$

$$50 \times 8 = 400$$

$$8 \text{ units} + 400 \rightarrow \text{Helen}$$

$$15 + 8 = 23$$

$$23 \text{ units} + 400 \rightarrow 1044$$

$$23 \text{ units} = 644$$

$$1 \text{ unit} = 644 \div 23$$

$$= 28$$

$$15 \text{ units} = 28 \times 15$$

$$= 420 \text{ (ans)}$$

Ans: 420 [4]

12

- 14 Susan had 117 beads and marbles altogether. The beads and marbles were either white or black. 20% of the beads and 50% of the marbles were white. There were as many black beads as black marbles.

(a) In the statement below, circle the phrase 'more than', 'fewer than' or 'the same as' that correctly describes the comparison between the number of beads and marbles Susan had.

The number of beads Susan had was  
( more than / fewer than / the same as )  
the number of marbles she had.

[1]

(b) How many beads did Susan have?

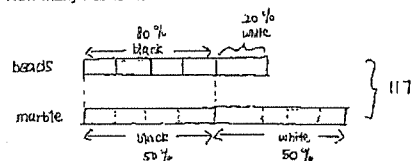

$$80\% = \frac{4}{5}$$

$$50\% = \frac{1}{2}$$

$$13 \text{ units} = 117$$

$$1 \text{ unit} = 117 \div 13$$

$$= 9$$

$$5 \text{ units} = 9 \times 5$$

$$= 45 \text{ (ans)}$$

$$\frac{4}{5} B \rightarrow \frac{1}{2} M$$

$$\frac{4}{5} B \rightarrow \frac{4}{8} M$$

$$5 + 8 = 13$$

$$13 \text{ units} = 117$$

$$5 \text{ units} = \frac{117}{13} \times 5$$

$$= 45 \text{ (ans)}$$

Ans: (b) 45 [3]

11

- 16 The figure below is made up of 2 squares, ABCD and DEFG. X is a point on GD and Y is a point on DE. BC = 7 cm, FE = 6 cm and XD = DY = YE.

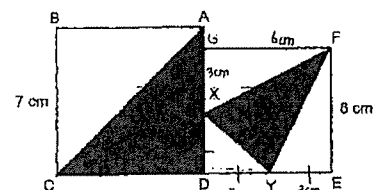

(a) Find the total area of the shaded parts.

$$6 \div 2 = 3$$

$$\text{Area of } \triangle ACD = \frac{1}{2} \times 7 \times 7$$

$$= 24.5$$

$$\text{Area of } \triangle XYF = \text{Area of DEFG} - \text{Area } \triangle DKY - \text{Area } \triangle YEF - \text{Area } \triangle XDF$$

$$= (6 \times 6) - (\frac{1}{2} \times 3 \times 3) - (\frac{1}{2} \times 3 \times 6) - (\frac{1}{2} \times 3 \times 6)$$

$$= 36 - 4.5 - 9 - 9$$

$$= 13.5$$

$$24.5 + 13.5 = 38 \text{ cm}^2 \text{ Ans: (a) } \underline{38 \text{ cm}^2} [3]$$

(b) What fraction of the figure is unshaded?

$$\text{Area of figure} = (7 \times 7) + (6 \times 6)$$

$$= 49 + 36$$

$$= 85$$

$$\text{Unshaded} \rightarrow 85 - 38$$

$$= 47$$

$$\frac{\text{Unshaded}}{\text{Total}} \rightarrow \frac{47}{85} \text{ (ans)}$$

Ans: (b)  $\frac{47}{85}$  [2]

13

6

- 17 The table below shows the number of clips in different coloured containers.

Colour of container	Number of clips in each container
White	30
Blue	50
Green	60

- (a) Gwen has a total of 10 white containers and green containers. What is the smallest possible difference between the total number of clips in Gwen's white containers and the total number of clips in her green containers?

Number of clips in green container is twice the number of clips in white container.

For every 2 white containers to 1 green container, the difference is zero.

$$2+1=3$$

$$10 \div 3 = 3R1$$

$$3 \times 2 + 1 = 7$$

$$10 - 7 = 3 \quad 7 \times 30 = 210 \quad \text{Ans: (a) } \underline{30} \quad (2)$$

$$3 \times 60 = 180 \quad 210 - 180 = 30 \text{ (Ans)}$$

- (b) Clement has some white containers and some blue containers. The ratio of the total number of clips in Clement's white containers to the total number of clips in his blue containers is 3 : 2. Express the number of his blue containers as a fraction of the total number of his containers.

white clips : blue clips

$$3 : 2$$

$$150 : 100$$

$$150 \div 30 = 5 \rightarrow \text{white containers}$$

$$100 \div 50 = 2 \rightarrow \text{blue containers}$$

$$2+5=7$$

$$\frac{\text{blue}}{\text{total}} \rightarrow \frac{2}{7} \text{ (Ans)} \quad \text{Ans: (b) } \underline{\frac{2}{7}} \quad (3)$$

End of Paper

9  
END

