



ROSYTH SCHOOL  
2023 PRELIMINARY EXAMINATION  
MATHEMATICS  
PRIMARY 6  
PAPER 1

Name: \_\_\_\_\_

Register No. \_\_\_\_\_

Class: Pr 6 - \_\_\_\_\_

Date: 22 August 2023

Parent's Signature: \_\_\_\_\_

Total Time for Booklets A and B : 1 hour

---

BOOKLET A

Instructions to Pupils:

1. Do not open this booklet until you are told to do so.
2. Follow all instructions carefully.
3. Shade your answers in the Optical Answer Sheet (OAS) provided.
4. You are **not** allowed to use a calculator.
5. Answer all questions.

Section	Maximum Mark	Marks Obtained
Paper 1 (Booklet A)	20	

\* This booklet consists of 8 pages (including this cover page).  
This paper is not to be reproduced in part or whole without the permission of the Principal.

Questions 1 to 10 carry 1 mark each. Questions 11 to 15 carry 2 marks each.  
For each question, four options are given. One of them is the correct answer.  
Make your choice (1, 2, 3 or 4). Shade the oval (1, 2, 3 or 4) on the Optical Answer Sheet.

*All diagrams in this paper are not drawn to scale unless stated otherwise.*

(20 marks)

---

1. Round 8.685 to 2 decimal places.

- (1) 8.60
- (2) 8.68
- (3) 8.69
- (4) 8.70

2. Simplify  $8a + 21 - 7 - 4a$

- (1)  $4a + 14$
- (2)  $4a + 28$
- (3)  $12a + 14$
- (4)  $12a + 28$

3. Which of the following is the same as 2050 cm?

- (1) 2 m 5 cm
- (2) 2 m 50 cm
- (3) 20 m 5 cm
- (4) 20 m 50 cm

Use the information given below to answer Questions 4 and 5.

Alyna conducted a survey of the favourite sport of the students in 4 classes. The results are shown below.

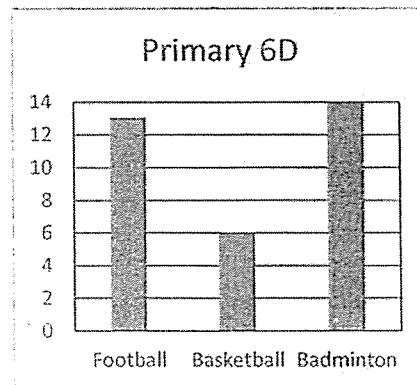
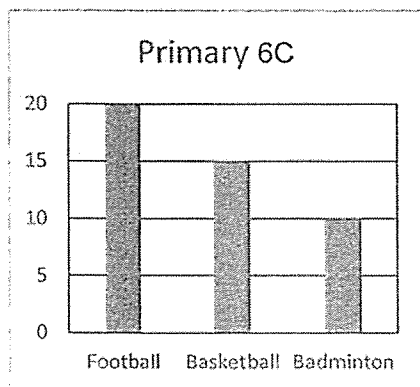
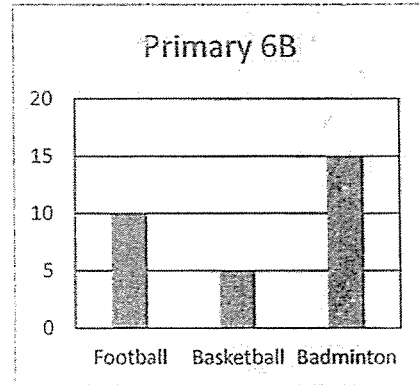
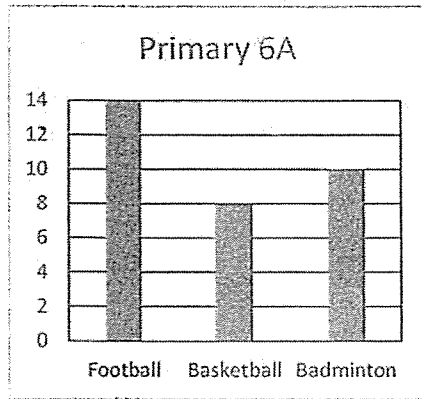

4 Which of the classes above has the greatest number of students choosing Football?

- (1) Primary 6A
- (2) Primary 6B
- (3) Primary 6C
- (4) Primary 6D

5 In these 4 classes, how many more students choose Badminton as compared to Basketball?

- (1) 15
- (2) 25
- (3) 34
- (4) 49

6. After traveling for 2 hours and 15 minutes, a train arrived in Kuala Lumpur from Singapore at 6.15 p.m. At what time did the train leave Singapore?

- (1) 3.45 p.m.
- (2) 4.00 p.m.
- (3) 4.15 p.m.
- (4) 8.30 p.m.

7. The figure below shows 12 identical squares. What is the least number of such squares that must be added to the figure so that the line AB becomes a line of symmetry?

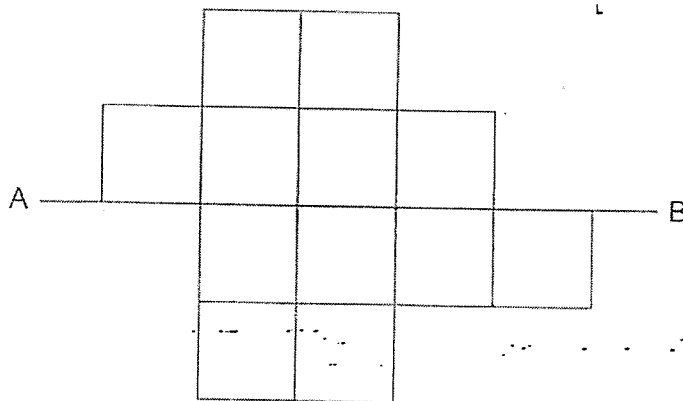

- (1) 1
- (2) 2
- (3) 3
- (4) 4

8 In the figure below,  $\overline{AB}$  and  $\overline{CD}$  are straight lines. Find  $\angle p$ .

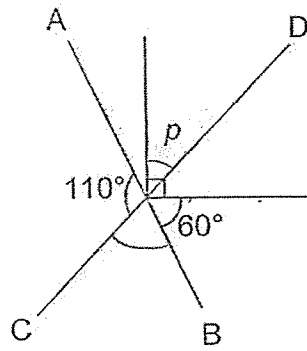

- (1)  $40^\circ$
- (2)  $45^\circ$
- (3)  $50^\circ$
- (4)  $70^\circ$

Refer to the square grid below and answer question 9.

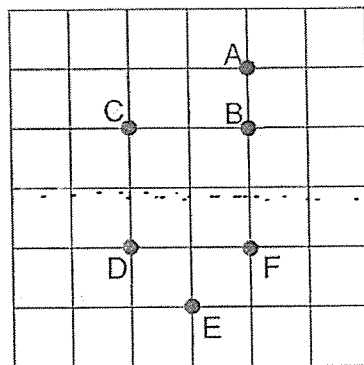

9. Which of the following statements is TRUE of the diagram shown above?

- (1) Point E is north-east of Point F
- (2) Point D is north-east of Point E
- (3) Point D is north-east of Point B
- (4) Point F is north-east of Point E

10. The postage rate for sending letters to Japan is shown below.

Postage Rate	
First 20 g	\$0.80
Per additional 10 g or part thereof	\$0.25

Mrs Tan sent a letter weighing 38 g to Japan. How much did she pay for the postage?

- (1) \$1.00
- (2) \$1.05
- (3) \$1.30
- (4) \$1.60

11. Mr Tan has 200 g of sugar. He wants to pack the sugar into 1000 packets equally. What is the mass of each packet of the sugar?

- (1) 0.02 g
- (2) 0.2 g
- (3) 50 g
- (4) 5 g

12. Eddie bought a card and a sunflower for \$8.20. Jane bought a card and 2 sunflowers for \$14. How much did a card cost?

- (1) \$2.40
- (2) \$5.80
- (3) \$11.60
- (4) \$22.20

13. Ansen and Beirul drank all the water in a bottle of water. Ansen drank 100 ml more than  $\frac{3}{8}$  of the total amount of water in the bottle. Beirul drank 250 ml. How much water was there in the bottle of water at first?

- (1) 150 ml
- (2) 240 ml
- (3) 350 ml
- (4) 560 ml

14. Three parts of a circle with a radius of 14 cm is shaded. These three parts add up to a quarter of the circle. What is the total perimeter of the three shaded parts?

Take  $\pi = \frac{22}{7}$

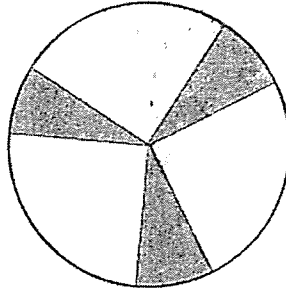

- (1) 22 cm  
 (2) 50 cm  
 (3) 95 cm  
 (4) 106 cm

15. ACE and BDF are equilateral triangles.  $AF = FE$  and  $BC = CD$ . Find  $\angle y$  in the figure.

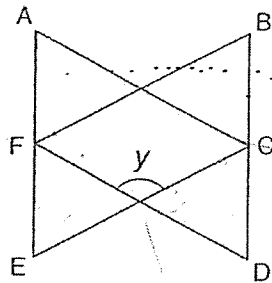

- (1)  $60^\circ$   
 (2)  $90^\circ$   
 (3)  $120^\circ$   
 (4)  $240^\circ$





ROSYTH SCHOOL  
2023 PRELIMINARY EXAMINATION  
MATHEMATICS  
PRIMARY 6  
PAPER 1

Name: \_\_\_\_\_

Register No. \_\_\_\_\_

Class: Pr 6 - \_\_\_\_\_

Date: 22 August 2023

Parent's Signature: \_\_\_\_\_

Total Time for Booklets A and B : 1 hour

---

**BOOKLET B**

Instructions to Pupils:

1. Do not turn over this page until you are told to do so.
2. Follow all instructions carefully.
3. Answer all questions.
4. Use a dark blue or black ballpoint pen to write your answers in the space provided for each question.
5. Do not use correction fluid/tape or highlighters.
6. You are not allowed to use a calculator.

Section	Maximum Mark	Marks Obtained
Paper 1 (Booklet B)	25	

\* This booklet consists of 10 pages (including this cover page).  
This paper is not to be reproduced in part or whole without the permission of the Principal.

Questions 16 to 20 carry 1 mark each. Write your answers in the spaces provided. For questions which require units, give your answers in the units stated.

Do not write in this space

**All diagrams in this paper are not drawn to scale unless stated otherwise.**

(5 marks)

16. Find the value of  $10 \times (24 + 36 \div 6)$ .

Ans: \_\_\_\_\_

17. The table below shows the mark Chelsie scored for 3 tests. What is the average mark she scored for these 3 tests?

Test 1	Test 2	Test 3
37	48	44

Ans: \_\_\_\_\_

18. Find the area of triangle ABC.

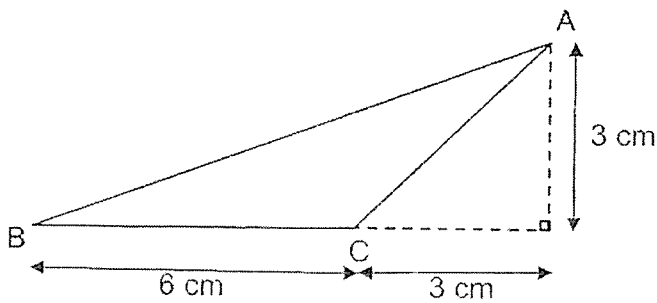

Ans: \_\_\_\_\_ cm<sup>2</sup>

19. The pie chart shows Natalie's expenditure last month. How much did she spend on food?

Do not write in this space

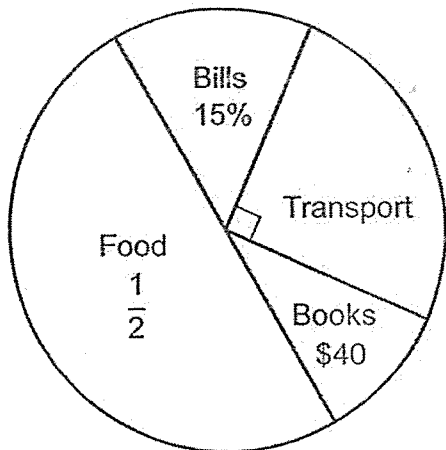

Ans: \$ \_\_\_\_\_

20. ABCD is a trapezium with AB parallel to DC.  $\angle ADC = 112^\circ$ . Find  $\angle BAD$ .

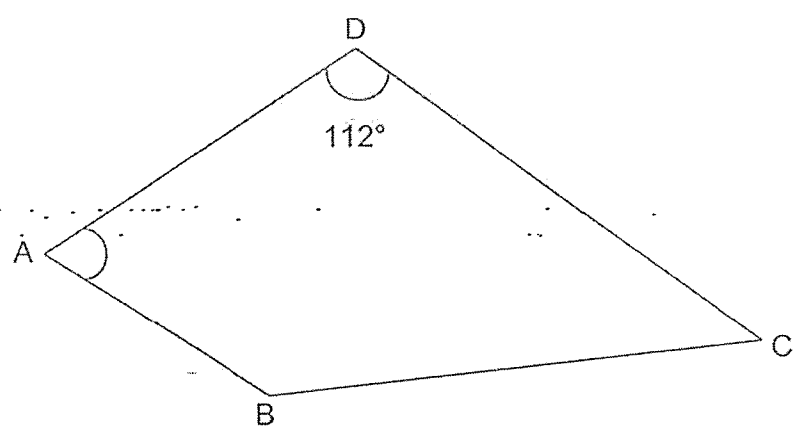

Ans: \_\_\_\_\_<sup>o</sup>

Questions 21 to 30 carry 2 marks each. Show your workings clearly in the space provided for each question and write your answers in the spaces provided. For questions which require units, give your answers in the units stated.

Do not write in this space

*All diagrams in this paper are not drawn to scale unless stated otherwise.*  
(20 marks)

---

21. Using all the digits 4, 9, 0, 5, form:

(a) the smallest 4-digit number that is a multiple of 5.

Ans: (a) \_\_\_\_\_

(b) a 4-digit number closest to 5000.

Ans: (b) \_\_\_\_\_

---

22. Dave had more money than Jerry. After Dave gave Jerry \$140, they have the same amount of money. How much more money did Dave have than Jerry at first?

Ans: \$ \_\_\_\_\_

---

23. Mr Fong bought a box of markers.  $\frac{1}{7}$  of the markers were black.  $\frac{1}{3}$  of the remaining markers were red and the rest were green. There were 400 green markers, how many markers did Mr Fong buy altogether?

Do not write  
in this space

Ans: \_\_\_\_\_

24. Uncle John sold  $(p + 4)$  muffins on Monday. He sold  $2p$  more muffins on Tuesday than on Monday. Altogether, he sold 240 muffins on the two days. Find the value of  $p$ .

Ans: \_\_\_\_\_

25. The table below shows the favourite subject of the students in Primary 6C. It is used to draw the pie chart shown. Mathematics is the most favourite subject amongst the students. Some parts of the table have been blanked off.

Do not write  
in this space

English		Science	
12	16		8

Favourite Subject

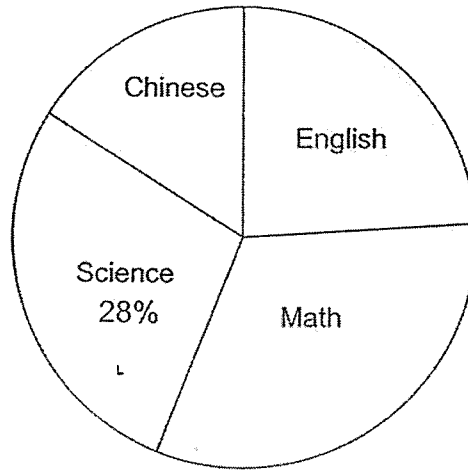

How many students chose Science as their favourite subject?

Ans: \_\_\_\_\_

26. Two squares of different sizes are drawn as shown below. An unshaded square is formed where the 2 squares overlap each other. The difference between the area of the shaded part A and the area of the shaded part B is  $24 \text{ cm}^2$ . Find the area of the unshaded part.

Do not write  
in this space

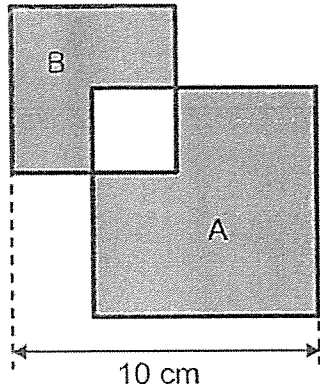

Ans: \_\_\_\_\_  $\text{cm}^2$

27. The solid is made up of nine 1-cm cubes.

Do not write  
in this space

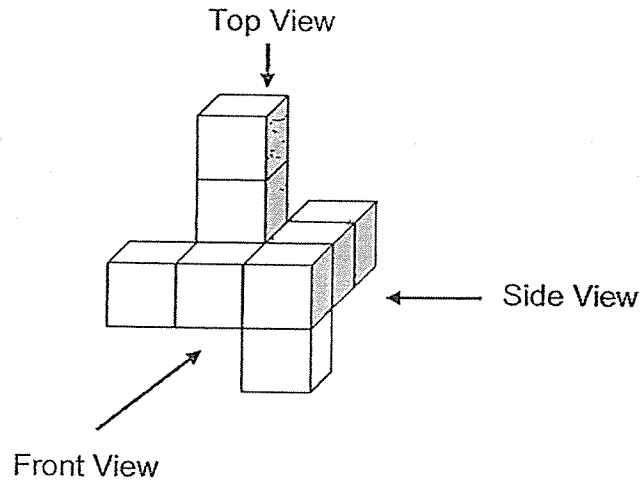

(a) Draw the top view of the solid on the grid below.

Top View

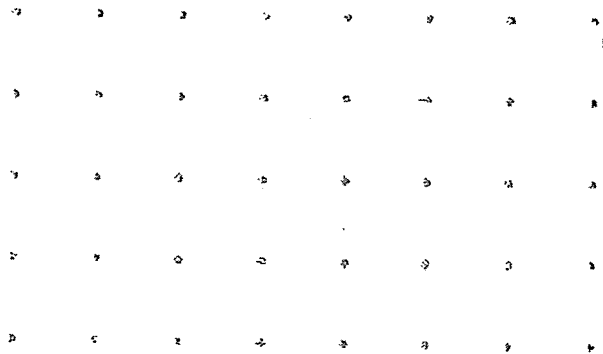

(b) Find the greatest number of cubes that can be added to the solid without changing the top view and the side view.

Ans: \_\_\_\_\_



28. (a) Complete the net of the solid figure in the grid below.

Do not write  
in this space

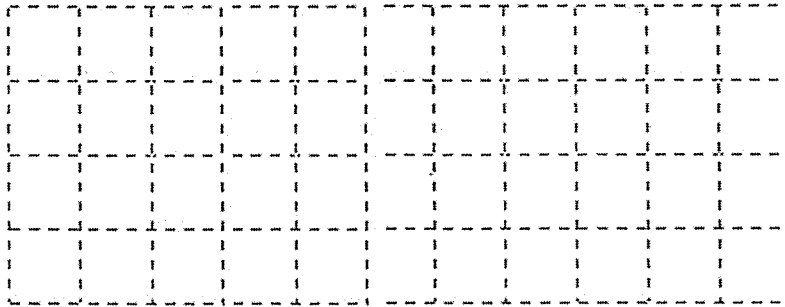
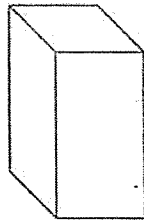

- (b) The net of the solid figure has an extra face. Identify the extra face and put a cross (X) over it.

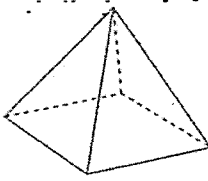
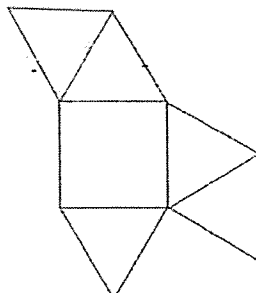
Solid Figure	Net - Put a (X) over the extra face
	

Do not write  
in this space

29. PQ and QR are two sides of a parallelogram.
- (a) Complete the drawing of the parallelogram PQRS.
- (b) QR also forms one side of an isosceles triangle QRT in which  $QR = RT$  and  $\angle QRT$  is an obtuse angle. Complete the drawing of the triangle QRT within the grid.

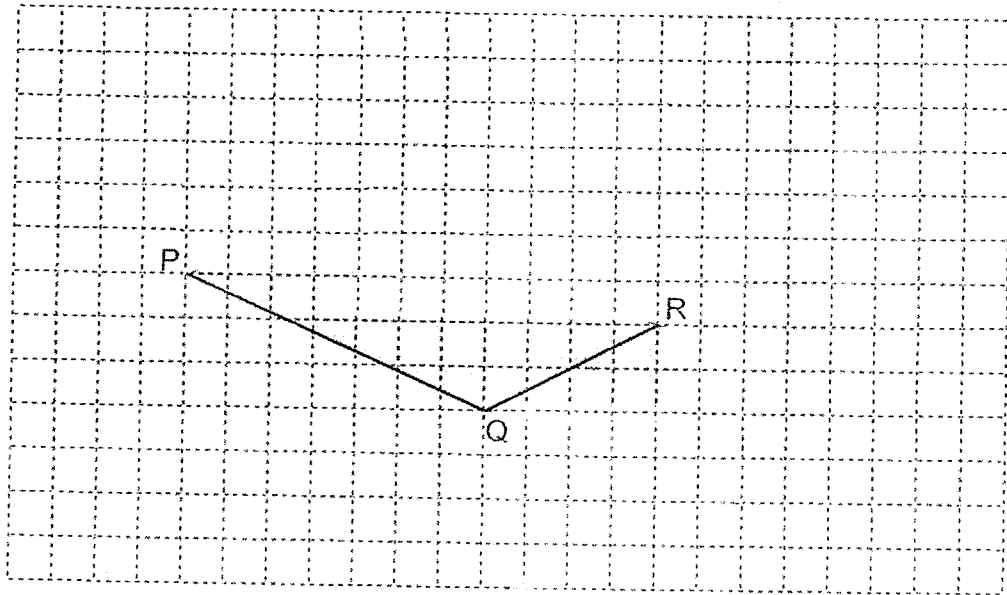

30. \$2 is paid for every box sealed. Mrs Lee can seal 12 boxes in 3 hours. How much will Mrs Lee get in a full week (including Saturday and Sunday) if she spends 6 hours each day sealing boxes?

Ans: \$ \_\_\_\_\_

End of paper  
Have you checked your work?



**ROSYTH SCHOOL**  
**2023 PRELIMINARY EXAMINATION**  
**MATHEMATICS**  
**PRIMARY 6**  
**PAPER 2**

Name: \_\_\_\_\_

Register No. \_\_\_\_\_

Class: Pr 6 - \_\_\_\_\_

Date: 22 August 2023

Parent's Signature: \_\_\_\_\_

Time: 1 h 30 min

Instructions to Pupils:

1. Do not turn over this page until you are told to do so.
2. Follow all instructions carefully.
3. Answer all questions.
4. Use a dark blue or black ballpoint pen to write your answers in the space provided for each question.
5. Do not use correction fluid/tape or highlighters.
6. The use of an approved calculator is allowed.

Questions	Maximum Mark	Marks Obtained
Q 1 to 5	10	
Q 6 to 17	45	

Section	Maximum Mark	Marks Obtained
Paper 1	45	
Paper 2	55	
<b>Total</b>	<b>100</b>	

\* This booklet consists of 18 pages (including this cover page)  
This paper is not to be reproduced in part or whole without the permission of the Principal.

Questions 1 to 5 carry 2 marks each. Show your working clearly in the space provided for each question and write your answers in the spaces provided. For questions which require units, give your answers in the units stated.

Do not write in this space

(10 marks)

*All diagrams in this paper are not drawn to scale unless stated otherwise.*

1. 13 pots of plants are arranged in a row of equal distance apart. The distance between the first pot of plant and the fifth pot of plant is  $1\frac{3}{4}$  m. What is the distance between the 2<sup>nd</sup> pot of plant and the 12<sup>th</sup> pot of plant?

Ans: \_\_\_\_\_ m

2. A tray of cookies is arranged in 3 rows. Each row has  $p$  more cookies than the row in front of it. There are  $5p$  cookies in the last row. How many cookies are there in the front row? Give your answer in terms of  $p$  in the simplest form.

Ans: \_\_\_\_\_

3. A strip of paper 60 cm long is folded to form the shape shown below.

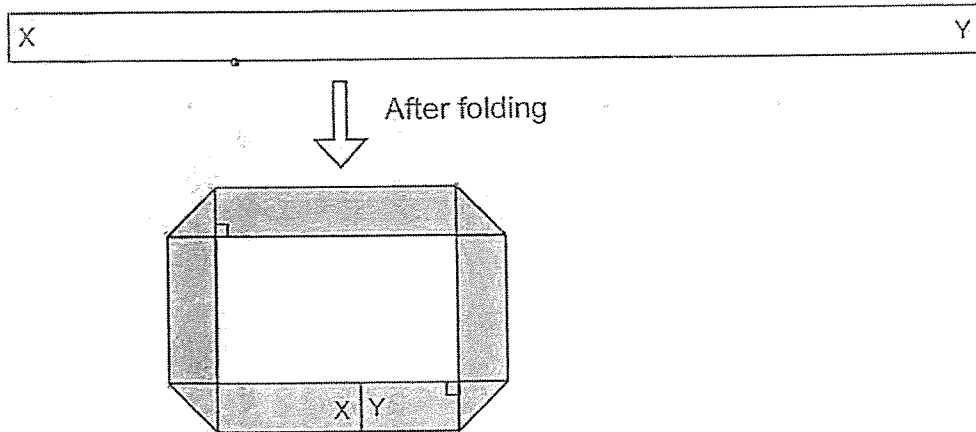

The difference in area between the strip of paper and the folded strip is  $18 \text{ cm}^2$ . Find the area of the shaded folded strip.

Do not write  
in this space

Ans: \_\_\_\_\_  $\text{cm}^2$

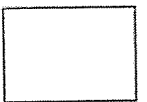

4. The figure below is made up of a trapezium and 2 parallel lines. Study the figure and answer the following questions,

Do not write in this space

- (a) which 2 angles add up to  $75^\circ$ ?

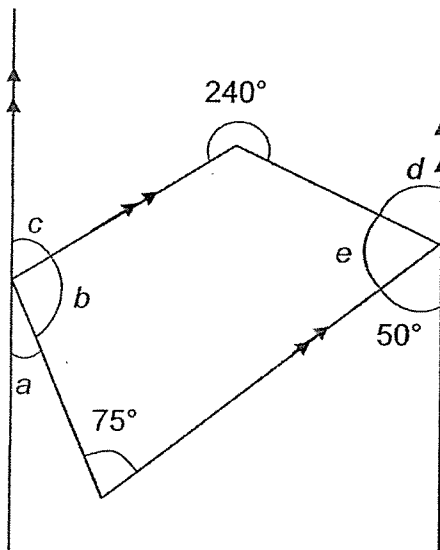

Ans: (a)  $\angle$  \_\_\_\_\_ and  $\angle$  \_\_\_\_\_ [1]

- (b) which 2 angles add up to  $165^\circ$ ?

Ans: (b)  $\angle$  \_\_\_\_\_ and  $\angle$  \_\_\_\_\_ [1]



5. Mrs Lee left Town P for Town Q, driving at an average speed of 60 km/h. 20 minutes later, Mr Kumar left Town Q for Town P, driving at an average speed of 80 km/h. Mrs Lee met Mr Kumar 50 minutes after she left Town P. What is the distance between Town P and Town Q?

Do not write  
in this space

Ans: \_\_\_\_\_ km

For Questions 6 to 17, show your working clearly in the space provided for each question and write your answers in the spaces provided. The number of marks available is shown in brackets [ ] at the end of each question or part-question. For questions which require units, give your answers in the units stated. (45 marks)

Do not write  
in this space

6. A school is collecting money for a donation drive.  $\frac{1}{2}$  of the students in the school donated \$3.  $\frac{2}{5}$  of them donated \$4. The rest of the students donated \$5. A total of \$9000 in donation is collected from the school. How many students are there in the school?

Ans: \_\_\_\_\_ [3]

7. At first, Jing Jing had a total of 4000 paper clips and magnets. After she gave away 50 paper clips and 10% of the magnets, she had a total of 1125 magnets left. How many paper clips did Jing Jing have at first?

Ans: \_\_\_\_\_ [3]



8. There are 210 students in the level and they are divided into groups of three. It is found that:
- 1) There are 23 groups with only 1 boy.
  - 2) There are 34 groups with two or more boys.
  - 3) The number of all-boy groups is twice the number of all-girl groups.
- How many girls are there in the level?

Do not write  
in this space

Ans: \_\_\_\_\_ [3]

9. There was 21.6 litres of water altogether in container A and container B. The water level in container A was the same as container B. The base area of container A was  $700 \text{ cm}^2$  and the base of container B has dimensions as shown.

Do not write in this space

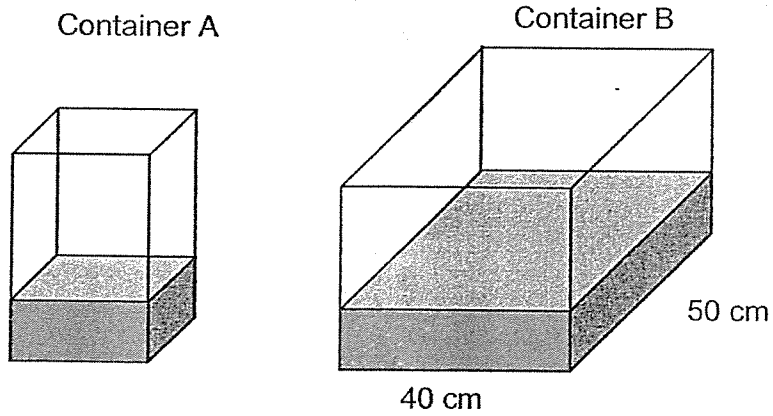

- (a) What was the height of water in container B?

Ans: (a) \_\_\_\_\_ [1]

- (b) From which container should water be poured out from such that both containers would have the same amount of water? How much water should be poured?

Ans: (b) Container \_\_\_\_\_

Ans: \_\_\_\_\_ [2]

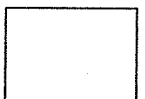

10. ABCD is a rhombus and CDEF is a parallelogram.  
Find  $\angle ACG$ .

Do not write  
in this space

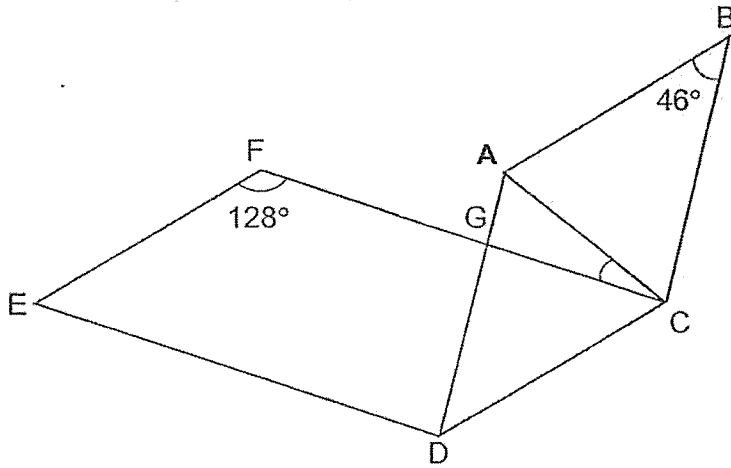

Ans: \_\_\_\_\_ [3]

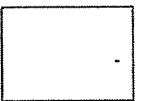

11. There were red, blue, white and green stickers in a bag. After the percentage of red stickers was increased by 60%, the percentage of blue stickers was decreased by 30% and  $\frac{2}{7}$  of the white stickers were coloured green, the number of each colour of stickers became the same. There were a total of 94 080 stickers in the end. Find the total number of stickers in the bag at first.

Do not write  
in this space

Ans: \_\_\_\_\_ [5]

12. The figure below is formed by a square  $ABCD$ , equilateral triangle  $ABE$  and triangles  $BDG$  and  $BEG$ .  $AFE$  and  $BFD$  are straight lines. Do not write in this space

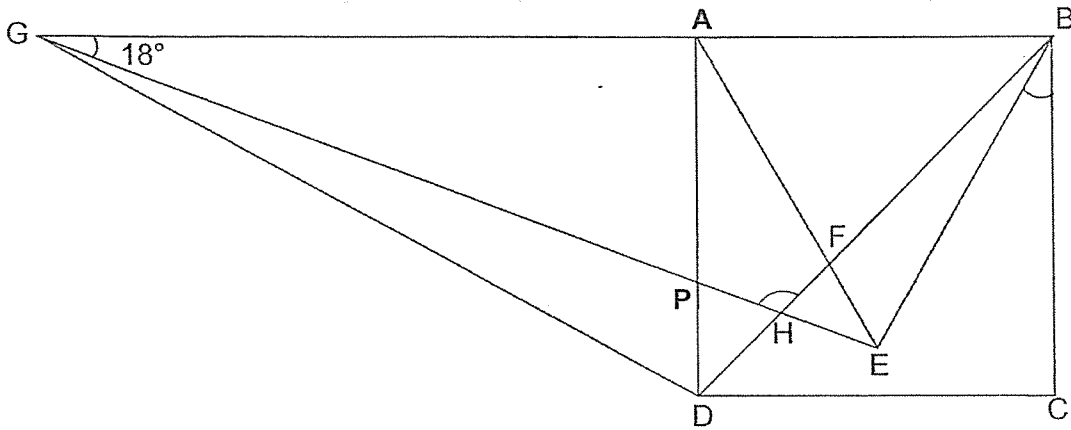

- (a) Find  $\angle CBE$ .

Ans: (a) \_\_\_\_\_ [2]

- (b) Find  $\angle BHG$ .

Ans: (b) \_\_\_\_\_ [2]

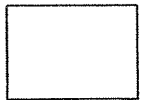

13. Shop A, Shop B and Shop C sells an identical pen at different prices. The price of the pen is shown in the table below.

Do not write in this space

Shop	Shop A	Shop B	Shop C
Price of 1 pen	\$1.20	\$1.50	\$1.00

The bar graph below shows the number of pens sold by the 3 shops on Monday and Tuesday.

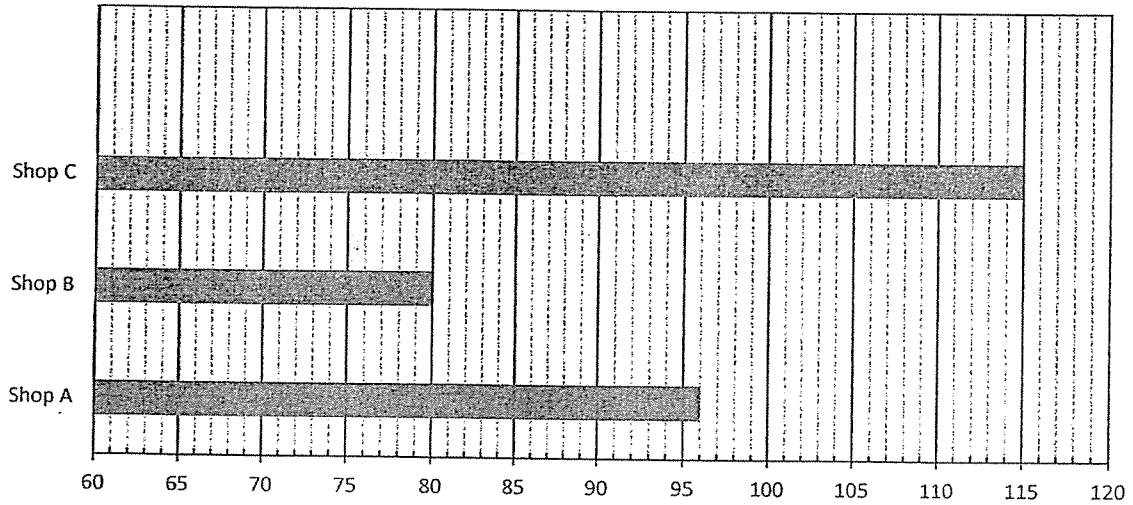

Monday

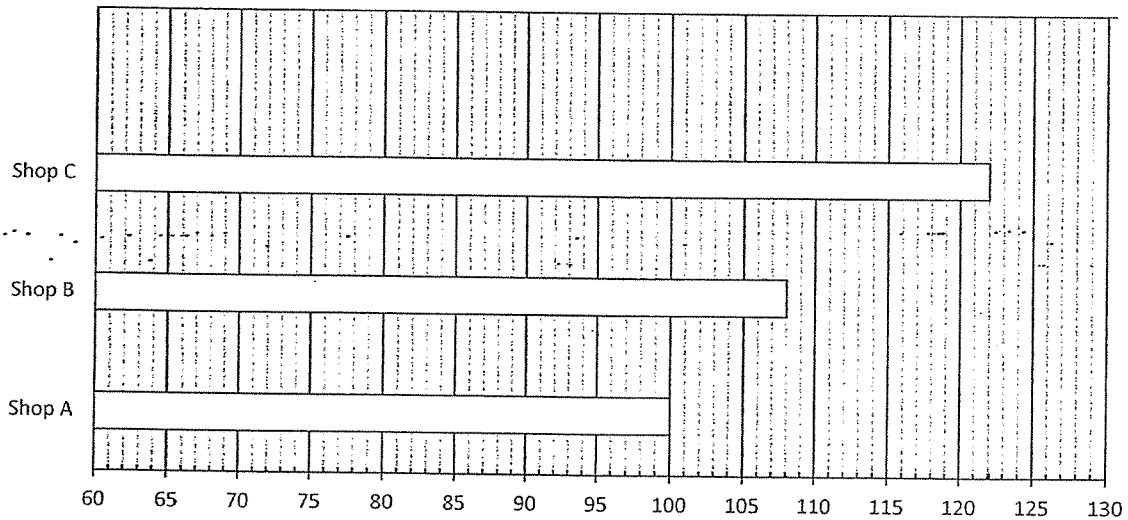

Tuesday

- (a) How much money was collected altogether by Shop A from the sale of the pens on Monday and Tuesday?

Ans: (a) \_\_\_\_\_ [1]

Continue with part (b) on the next page.

- (b) What was the percentage increase in the number of pens sold by shop C from Monday to Tuesday? Round your answer to 2 decimal places.

Do not write  
in this space

Ans: (b) \_\_\_\_\_ [1]

- (c) On Tuesday, a discount was given in Shop B. Shop B collected \$6.60 less on Tuesday than Monday. What was the percentage discount given in shop B on Tuesday?

Ans: (c) \_\_\_\_\_ [2]



14. The graph below shows the total number of cars painted by two different robots, Robot A and Robot B over a period of 10 hours at a constant rate.

Do not write in this space

Robot B stopped working after 5 hours while Robot A continued painting the cars at the same constant rate as before.

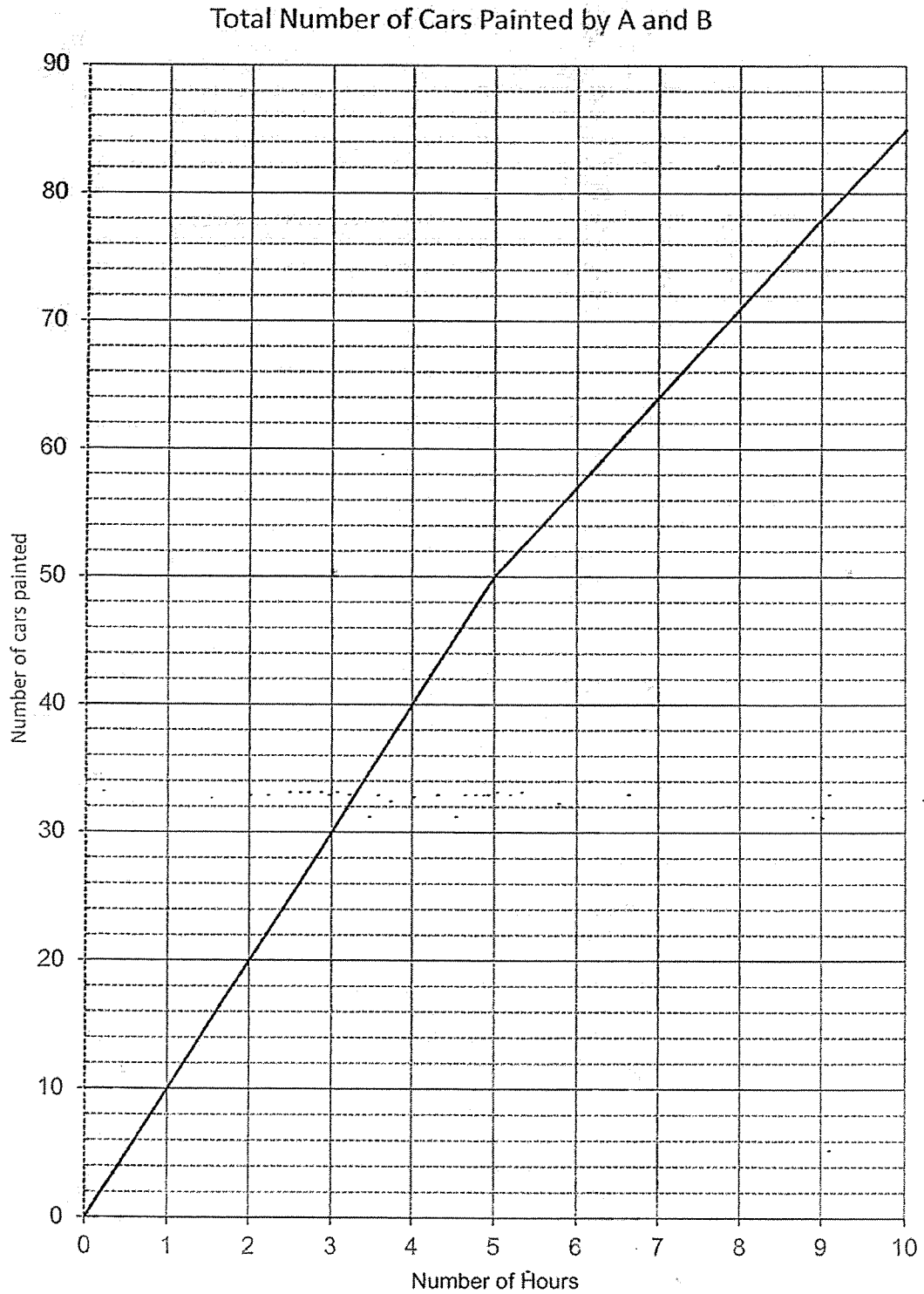

Answer the questions on the next page.



- (a) How many cars did Robot A and B paint altogether before Robot B stopped working?

Do not write  
in this space

Ans: (a) \_\_\_\_\_ [1]

- (b) How many cars did Robot A paint over the 10 hours?

Ans: (b) \_\_\_\_\_ [3]



15. The figure shown is made up of rectangle  $ABCD$ , a circle with  $FG$  as the diameter, 2 identical small semi-circles with diameters  $EF$  and  $GH$  and 2 larger semi-circles with diameters  $EG$  and  $FH$ . The radius of the circle  $FG$  is  $18\text{ cm}$ .  $EH$  is a straight line. The length of  $BC$  is  $60\text{ cm}$ .

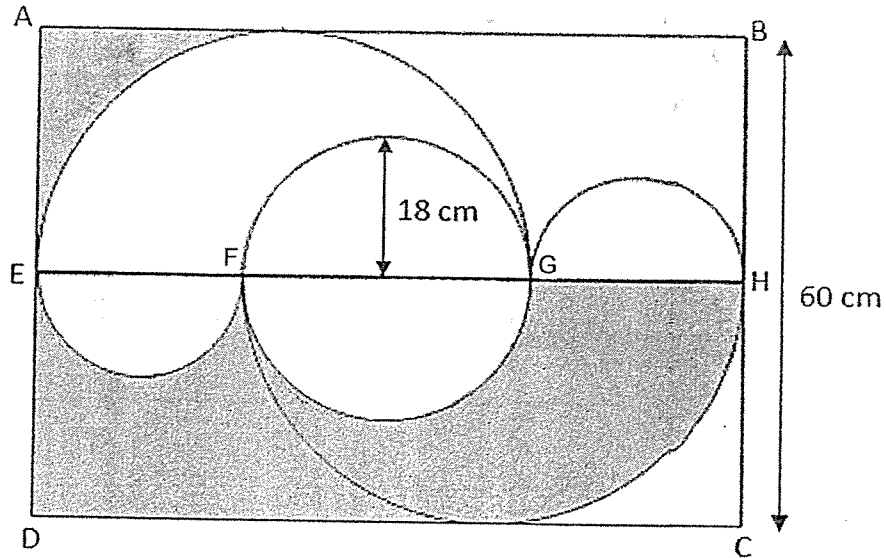

- (a) Find the length of  $EF$ .

Ans: (a) \_\_\_\_\_ [1]

- (b) Find the total area of all the shaded parts. (Take  $\pi = 3.14$ )

Ans: (b) \_\_\_\_\_ [3]

Do not write  
in this space

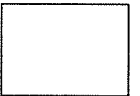



17. Laptops were sold at the discount stated below.

Do not write  
in this space

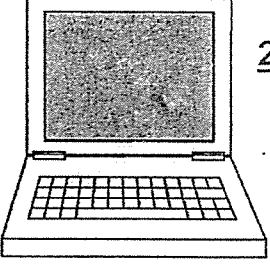

**2023 Great SG Laptop Sale!**

1<sup>st</sup> laptop – 15% discount  
2<sup>nd</sup> laptop – 30% discount  
3<sup>rd</sup> laptop – 40% discount

Jian Hao paid a total of \$5805 for 3 similar laptops during the 2023 Great SG Laptop Sales. The amount that he paid includes an 8% GST.

- (a) What was the original price of a laptop without GST?

Ans: (a) \_\_\_\_\_ [2]

- (b) If he had bought the 3 laptops without any discount, how much more would he have to pay not including the GST?

Ans: (b) \_\_\_\_\_ [2]

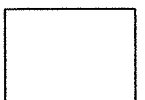

SCHOOL : Rosyth SCHOOL  
 LEVEL : PRIMARY 6  
 SUBJECT : MATH  
 TERM : 2023 Prelims

PAPER 1 BOOKLET A

Q 1	Q2	Q3	Q4	Q5	Q6	Q7	Q8	Q9	Q10
3	1	4	3	1	2	2	1	4	3

Q 11	Q12	Q13	Q14	Q15
2	1	4	4	3

PAPER 1 BOOKLET B

Q16)	$10 * (24 + 36 \div)$ $= 10 * (24 + 6)$ $= 10 * 30$ $= 300$
Q17)	Total = $37 + 48 + 44 = 129$ Average = $129 \div 3 = 43$
Q18)	$\frac{1}{2} * 6 * 3 = 9$
Q19)	$100\% - 25\% - 15\% - 50\% = 10\%$ $10U: 40$ $50U: 40 * 5 = 200$
Q20)	$180^\circ - 112^\circ = 68^\circ$
Q21)	a) 4095 b) 5049
Q22)	\$280
Q23)	$4U: 400$ $1U: 100$ $7U: 700$
Q24)	Monday: (P+4) Tuesday: (3P+4)

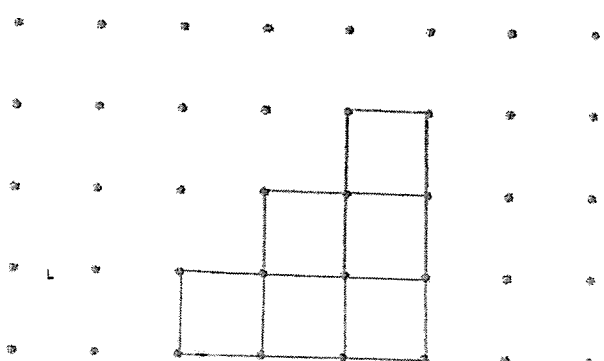
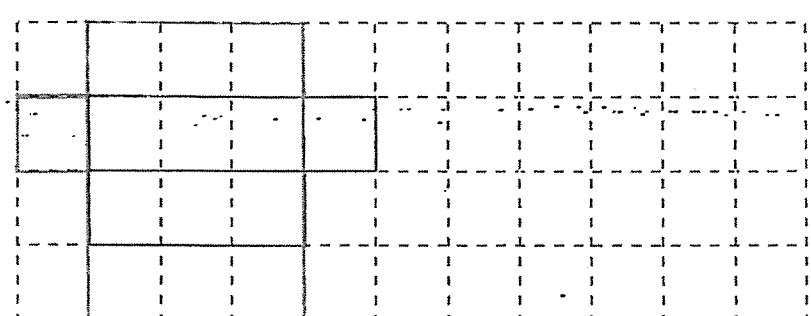
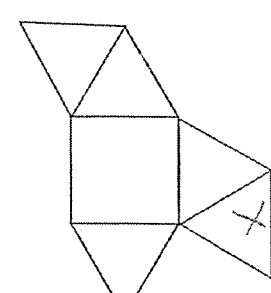
	<p>Altogether: <math>4P+8</math></p> <p><math>4P + 8 = 240</math>  <math>4P = 240 - 8 = 232</math>  <math>1P = 232 \div 4 = 58</math></p>
Q25)	<p><math>100u - 28u = 72U</math>  <math>72U = 12 + 16 + 8 = 36</math>  <math>1U = 36 \div 72 = 0.5</math>  <i>Science</i>(<math>28U</math>) = <math>28 * 0.5 = 14</math></p>
Q26)	4
Q27)	<p style="text-align: center;">Top View</p>  <p>a) b) 4</p>
Q28 a)	
Q28 b)	

Q29	
Q30	<p>1 Day = 24  7 Days = 7 * 24 = 168  168 * \$2 = \$336</p>

**PAPER 2**

Q1)	<p>1st to 5th = 4 gaps  <math>4 \text{ gaps} = 1\frac{3}{4} = 175\text{cm}</math>  2nd to 12th = 10 gaps  <math>10\text{gaps} = \frac{175\text{cm}}{4} * 10 = 437.5\text{cm} = 4.375\text{m}</math></p>
Q2)	$5P - 2P = 3P$
Q3)	<p>Width of the strip = <math>\sqrt{9\text{cm}^2} = 3\text{cm}</math>  Area of unfolded stripe = <math>60\text{cm} * 3\text{cm} = 180\text{cm}^2</math>  Area of shaded folded stripe = <math>180\text{cm}^2 - 18\text{cm}^2 = 162\text{cm}^2</math></p>
Q4a)	<p><math>180^\circ - 60^\circ - 50^\circ = 70^\circ</math>  <math>180^\circ - 120^\circ = 60^\circ</math>  Answer: A and C</p>
Q4b)	<p><math>\angle B + \angle E = 360^\circ - 120^\circ - 75^\circ = 165^\circ</math>  Answer: <math>\angle B</math> and <math>\angle e</math></p>
Q5)	<p>Mrs Lee  S: 60km/hour  T: 50 mins = <math>\frac{5}{6}h</math>  <math>D = S * T = 60\text{km/h} * \frac{5}{6}h = 50\text{km}</math></p> <p>Mr Kumar  S: 80km/hour</p>

	<p><math>T: 30\text{mins} = \frac{1}{2}h</math>  <math>D = S * T</math>  <math>= 80\text{km/h} \times \frac{1}{2}h</math>  <math>= 40\text{km}</math></p> <p>Total Distance = 40km + 50km = 90km</p>
Q6)	<p><math>15u + 6u + 5u = 36u</math>  <math>36u = 9000</math>  <math>1u = 9000 \div 36 = 250</math>  <i>Students</i> = <math>10 * 250 = 2500</math></p>
Q7)	<p><math>9u = 1125</math>  <math>1u = 1125 \div 9 = 125</math>  <math>10u = 10 * 125 = 1250</math>  <i>Paper clip at first</i> = <math>4000 - 1250 = 2750</math></p>
Q8)	<p><math>210 \div 3 = 70</math>  All girls teams = <math>70 - (34 + 23) = 13</math>  All boys teams = <math>13 * 2 = 26</math>  Two boys One Girl = <math>34 - 26 = 8</math>  One boy 2 Girls = 23  Total Girls = <math>(13 * 3) + (1 * 8) + (23 * 2) = 39 + 8 + 46 = 93</math></p>
Q9a)	<p>Based area of B = <math>50\text{cm} \times 40\text{cm} = 2000\text{cm}^2</math>  21.6litres = <math>21600\text{cm}^3</math>  Height in both = <math>21600\text{cm}^3 \div (700\text{cm}^2 + 2000\text{cm}^2) = 8\text{cm}</math></p>
Q9b)	<p>Answer: Container B</p> <p><math>A = 8 * 700 = 5600</math>  <math>B = 8 * 2000 = 1600</math></p> <p><math>21600 \div 2 = 10800</math></p> <p>To pour <math>16000 - 10800 = 5200\text{cm}^3</math></p>
Q10)	<p><math>\angle DCG = 180^\circ - 128^\circ = 52^\circ</math>  <math>\angle ACB = (180^\circ - 46^\circ) \div 2 = 67^\circ</math>  <math>\angle BAD = 180^\circ - 46^\circ = 134^\circ</math>  <math>\angle ACG = 134^\circ - 52^\circ - 67^\circ = 15^\circ</math></p>
Q11)	<p><math>4 * 560n = 2240n</math>  <math>2240u = 94080</math>  <math>1u = 94080 \div 2240 = 42</math>  <math>350u + 800u + 784u + 336u = 2270u</math>  <math>2270u = 2270 * 42 = 95340</math></p>



Q12a )	$\angle HEF = 180^\circ - 18^\circ - 60^\circ - 60^\circ = 42^\circ$ $\angle APH = 180^\circ - 30^\circ - 42^\circ = 108^\circ$ $\angle CBE = 90^\circ - 60^\circ = 30^\circ$
Q12b )	$\angle BHG = 360^\circ - 105^\circ - 30^\circ - 108^\circ = 117^\circ$
Q13a )	$196 * 1.2 = 235.20$
Q13b )	$\frac{7}{115} * 100\% \approx 6.09\%$
Q13c )	$\$162 - \$113.40 = \$48.60$ $\$48.60 \div 108 = \$0.45$ $\$1.50 - \$0.45 = \$1.05$ $\frac{\$0.45}{\$1.50} * 100\% = 30\%$
Q14a )	50
Q14b )	A- 5hours = $80 - 50 = 35$ A- 1hour = $35 \div 5 = 7$ 10hours = $10 * 7 = 70\text{hours}$
Q15a )	$60\text{cm} \div 2 = 30\text{cm}$ $EG = 30\text{cm} * 2 = 60\text{cm}$ $EF = 60\text{cm} - 36\text{cm} = 24\text{cm}$
Q15b )	$\angle DEH = 30 * 84 = 2520$ $\bigcirc = \frac{1}{2} * 12 * 12 * 3.14 = 226.08$ $\bigcirc = \frac{1}{2} * 18 * 18 * 3.14 = 508.68$ $2520 - 226.08 - 508.68 = 1785.24\text{cm}^2$
Q16a )	$103 + 7 = 110$
Q16b )	20 <sup>th</sup> Corner: 118 21 <sup>th</sup> Corner: 129  <b>Formula</b> $N^{\text{th}} \text{ Corner} = 8 + \left[ \frac{n}{2} * \left( \frac{n}{2} * 11 \right) \right]$
Q17a )	$85u + 70u + 60u = 215u$ $215u = 5805$ $1u = 5805 \div 215 = \$27$ $100u = 100 * \$27 = \$2700$ $\text{Original Price} = \frac{2700}{108} * 100 = 2500$

Q17b )	$\$2500 * 3 = \$7500$ $\$7500 - \$5375 = \$2125$
-----------	---