

**Anglo-Chinese School
(Junior)**



**BITE-SIZED ASSESSMENT TWO (2023)
PRIMARY 4**

MATHEMATICS

Thursday

4 May 2023

45 min

INSTRUCTIONS TO PUPILS

DO NOT TURN OVER THE PAGES UNTIL YOU ARE TOLD TO DO SO

Follow all instructions carefully.

There are 13 questions in this booklet.

Answer ALL questions.

You are not allowed to use a calculator.

Name: _____ ()

Class: 4. ()

Parent's Signature: _____

Section	Possible Marks	Marks Obtained
A	7	
B	7	
C	11	
TOTAL	25	

This question paper consists of 10 printed pages. (Inclusive of cover page)

Section A

Questions 1 to 3 carry 1 mark each.

Questions 4 and 5 carry 2 marks each.

For each question, four options are given. One of them is the correct answer. Make your choice and write its number (1, 2, 3 or 4) in the brackets provided. (7 marks)

1. In the figure below, which angle is greater than a right angle?

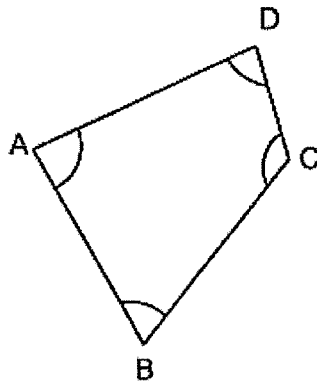

- 1) $\angle ABC$
- 2) $\angle BAD$
- 3) $\angle CDA$
- 4) $\angle DCB$

()

2. Which of the following figures is a symmetric figure?

1)

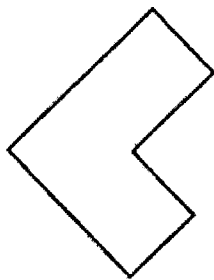

2)

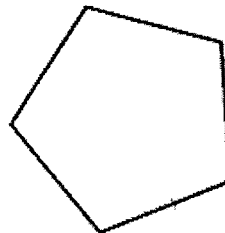

3)

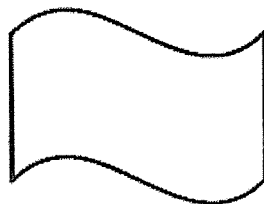

4)

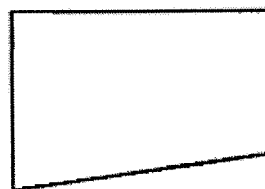

()

2

Sub-Total:

3. The figure below is not drawn to scale. KLMN is a square. Find $\angle e$.

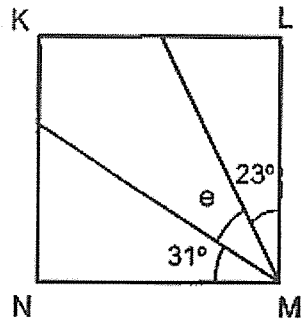

- 1) 36°
- 2) 46°
- 3) 59°
- 4) 67°

()

4. John is facing south-west. When he turns through an angle of _____ in an anti-clockwise direction, he will be facing east.

- 1) 45°
- 2) 90°
- 3) 135°
- 4) 225°



()

3

Sub-Total:

5. The figure below is made up of 2 identical squares of side 4 cm, a rectangle A with breadth 5 cm and a square B. Find the length of rectangle A.

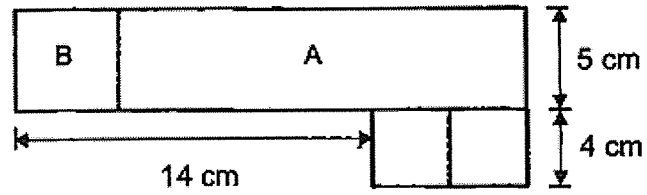

- 1) 9 cm
- 2) 17 cm
- 3) 18 cm
- 4) 22 cm

()

Section B

Questions 6 to 8 carry 1 mark each.

Questions 9 and 10 carry 2 marks each.

Show your working clearly in the space provided for each question and write your answers in the spaces provided. For questions which require units, give your answers in the units stated. (7 marks)

6. Use a protractor to measure $\angle XYZ$.

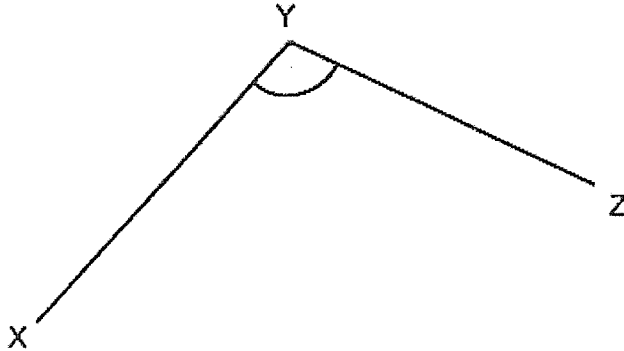

7. In the figure below, what is the least number of squares that must be added so that AB is the line of symmetry for the figure.

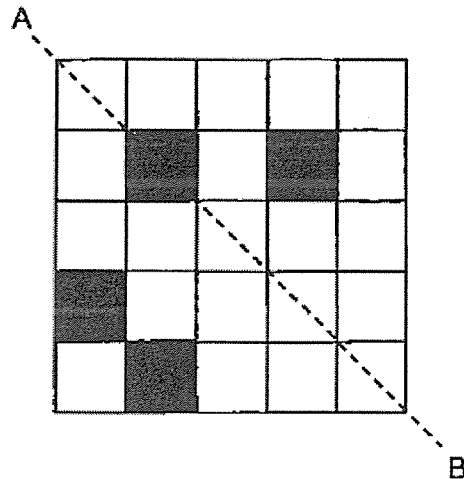

5

Sub-Total:

8. In the square grid below, two sides of a rectangle have been drawn. Complete the drawing of the rectangle within the grid with the given lines.

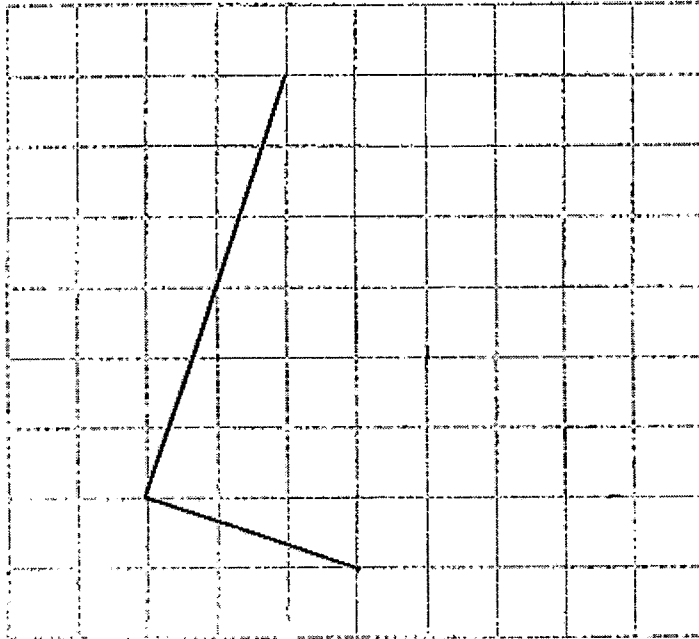

9. The figure below is not drawn to scale. EF is perpendicular FG and $\angle p = \angle q$. Find $\angle p$.

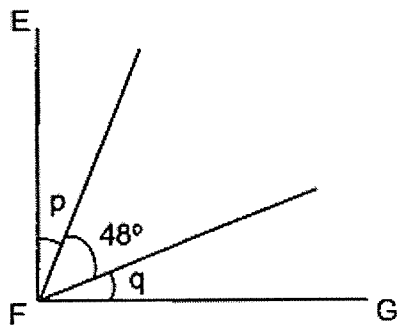

6

Sub-Total:

10. Study the diagram below.

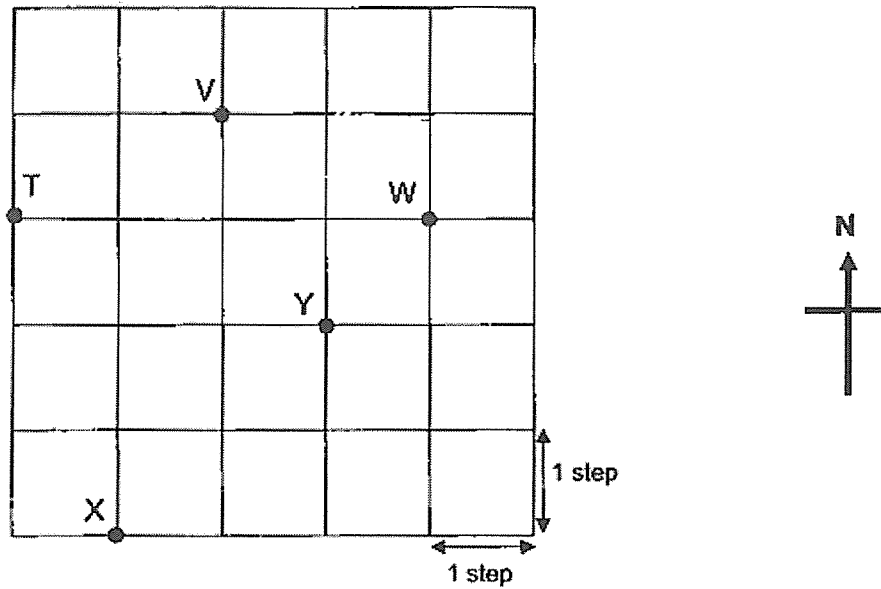

Perry was at a certain position. He walked 2 steps due north, 1 step due east, 4 steps due south and then 3 steps due west. He ended at Position X. What was his starting position?

Position _____

7

Sub-Total:

Section C

For questions 11 to 13, show your working clearly and write your answers in the spaces provided. The number of marks available is shown in brackets [] at the end of each question or part-question. (11 marks)

11. Mr Lim had 528 mangoes. He sold all the mangoes at 6 for \$14. How much money did he receive?

Ans: _____ [3]

8

Sub-Total:

12. Mrs Tan baked three times as many banana muffins as chocolate muffins. After she gave away 16 chocolate muffins, there were 5 times as many banana muffins as chocolate muffins. How many chocolate muffins did she bake at first?

Ans: _____ [4]

Sub-Total:

13. Rina had 5 times as many red beads as blue beads at first. She then gave away 36 red beads and bought another 36 blue beads. She had the same number of red beads and blue beads in the end. How many red beads did she have in the end?

Ans: _____ [4]

~ End of Paper ~

10

Sub-Total:

SCHOOL : ACS (J) PRIMARY SCHOOL
 LEVEL : PRIMARY 4
 SUBJECT : MATH
 TERM : WA2 (2023)

Q 1	Q2	Q3	Q4	Q5
4	2	1	3	2

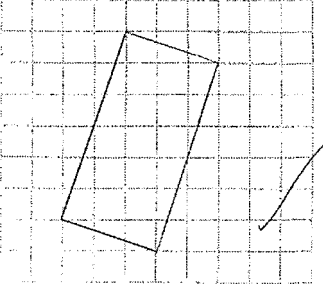
Q6)	108°
Q7)	3
Q8)	
Q9)	$90 - 48 = 42^\circ$ $42 \div 2 = 21^\circ$
Q10)	Y
Q11)	$528 \div 6 = 88$ $88 \times 14 = 1232$ Mr Lim receive \$1232
Q12)	$2u \rightarrow 16 \times 3 = 48$ $1u \rightarrow 48 \div 2 = 24$ $24 + 16 = 40$ She bake 40 chocolate muffins at first.
Q13)	$36 \div 2 = 18$ $3 \times 18 = 54$ She have 54 red beads in the end.

