



SINGAPORE CHINESE GIRLS' SCHOOL
SECOND SEMESTRAL ASSESSMENT 2022

**PRIMARY 3
SCIENCE
BOOKLET A**

Additional Materials: Optical Answer Sheet (OAS)

Total Time for Booklets A and B: 1 h 25 min

Name : _____ ()

28 October 2022

Class : Primary 3 SY / C / G / SE / P

INSTRUCTIONS TO CANDIDATES

1. Do not open this booklet until you are told to do so.
2. Follow all instructions carefully.
3. Answer all questions.
4. Shade your answers on the Optical Answer Sheet (OAS) provided.

This booklet consists of 10 printed pages.



Booklet A: 40 marks

For each question from 1 to 20, four options are given. One of them is the correct answer. Make your choice (1, 2, 3 or 4) and shade your answer on the Optical Answer Sheet.

1. Look at the four pictures below.

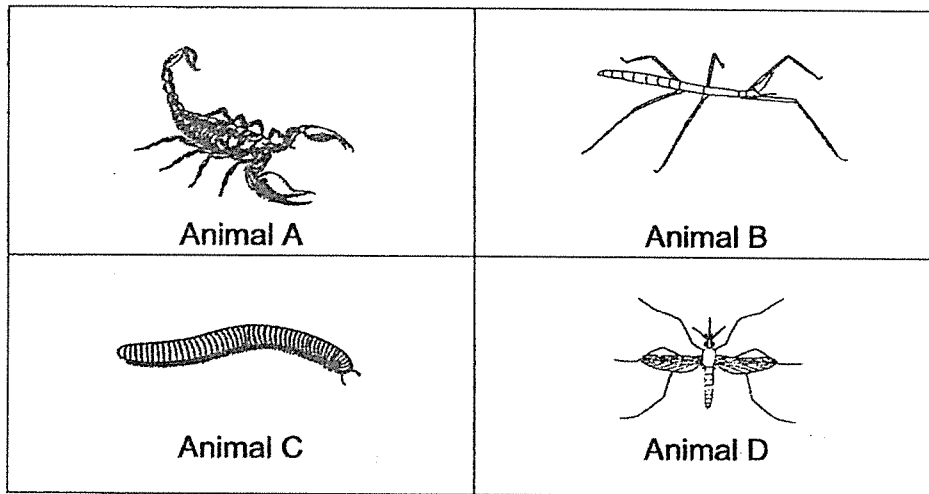

Which of the animals is/are insect(s)?

- (1) Animal A only
- (2) Animal B only
- (3) Animals A and C only
- (4) Animals B and D only

2. Study the classification table below.

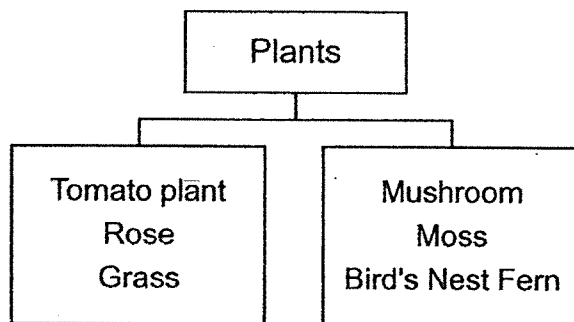

Which of the following is grouped wrongly?

- (1) Tomato plant
- (2) Grass
- (3) Mushroom
- (4) Moss

3. The diagram below shows four animals.

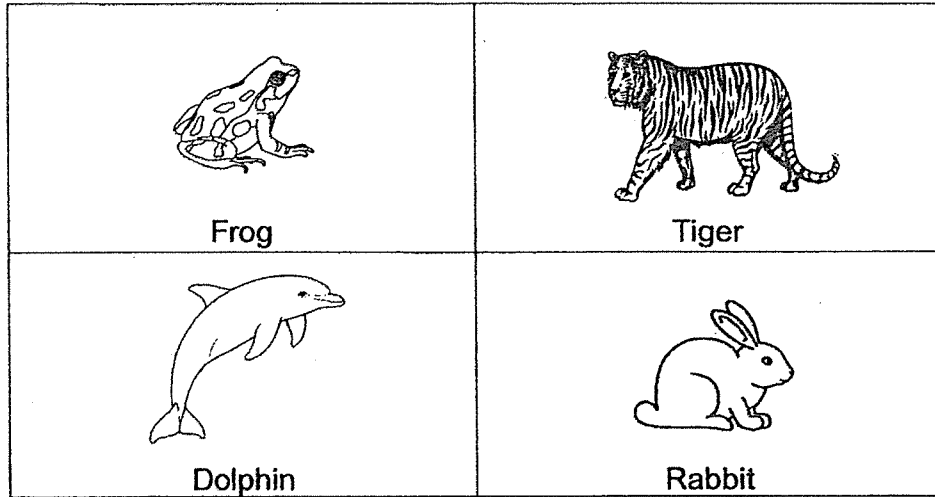

Which of the animals above **does not** give birth to its young alive?

- (1) Frog
- (2) Tiger
- (3) Dolphin
- (4) Rabbit

4. The diagrams below show bread mould and a fern.

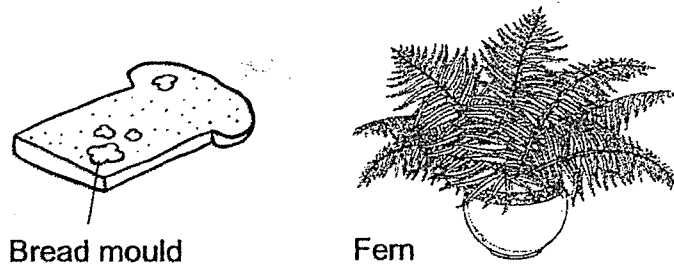

Which of the following statements is true?

- (1) Both make their own food.
- (2) Both reproduce by spores.
- (3) Only the fern produces flowers.
- (4) Only the bread mould can make its own food.

5. The properties of object R are shown below.

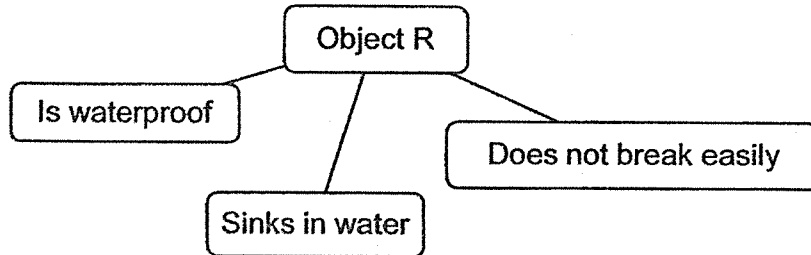

Which of the following objects could object R be?

- A: Glass cup
- B: Steel Paper clip
- C: Copper coin
- D: Handkerchief

- (1) A only
- (2) B only
- (3) B and C only
- (4) C and D only

6. The diagram below shows a few kickboards that are used for swimming.

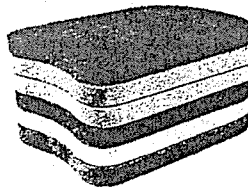

Peter has four different materials W, X, Y and Z and the table below shows the properties of materials

Materials	Waterproof	Transparent	Able to float
W	✓	✓	
X	✓		✓
Y			
Z	✓		

Which of the materials is the most suitable for making a kickboard?

- (1) Material W
- (2) Material X
- (3) Material Y
- (4) Material Z

7. Study the classification chart below.

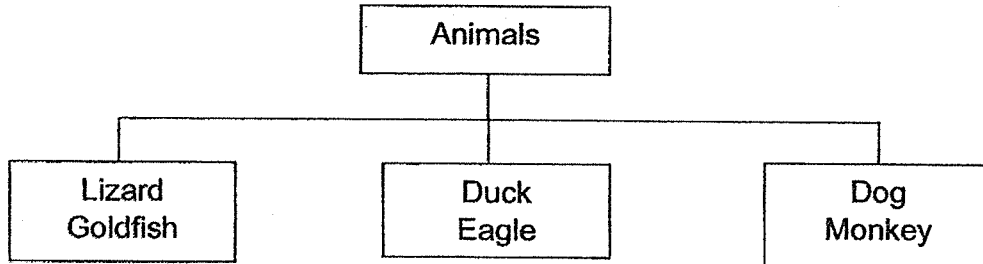

The animals above are classified according to _____.

- (1) how they move
- (2) where they live
- (3) their outer body covering
- (4) how they reproduce

8. The functions of three body systems are stated below.

System P: Takes air into the body.

System Q: Carries digested food to all parts of the body.

System R: Protects organs in the body.

Which of the following identified the systems correctly?

	System P	System Q	System R
(1)	Circulatory system	Digestive system	Skeletal system
(2)	Respiratory system	Circulatory system	Skeletal system
(3)	Circulatory system	Digestive system	Muscular system
(4)	Respiratory system	Circulatory system	Digestive system

9. Three pupils had a discussion on human body systems.

The heart is part of the circulatory system.

Ally

Benny

The lungs are part of the circulatory system.

The windpipe is part of the respiratory system.

Caleb

Who is/are correct?

(1) Ally and Benny

(3) Benny and Caleb

(2) Ally and Caleb

(4) All of them

10. Terry swims every weekend.



Which of his body systems is/are involved when he swims?

A: Skeletal system

B: Respiratory system

C: Circulatory system

D: Muscular system

(1) B only

(3) C and D only

(2) B and D only

(4) All of the above

11. Where does digestion begin in the human body?

- (1) Mouth
- (2) Gullet
- (3) Stomach
- (4) Small intestine

12. Look at the plant below.

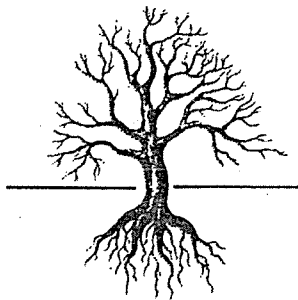

Which of the following is the plant unable to do?

- (1) Make food
- (2) Absorb water
- (3) Transport water
- (4) Hold the plant firmly in the soil

13. Keira noticed that an adult plant has more and longer roots than a young plant.

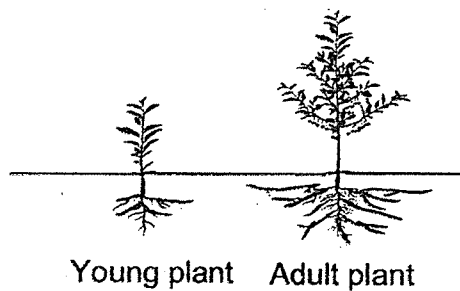

What is the reason for this?

- (1) To take in more air for the plant.
- (2) To make more food for the plant.
- (3) To hold the plant more firmly in the soil.
- (4) To store more food for the plant.

14. Which of the following will not cause a magnet to lose its magnetism?

- (1) Dropping the magnet many times
- (2) Hammering the magnet
- (3) Heating it over a flame
- (4) Stroking it with a copper nail

15. Which of the following shows how paper clips could be attracted to a magnet?

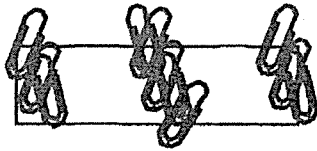

(1)

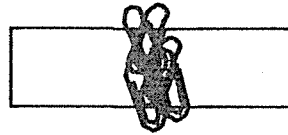

(3)

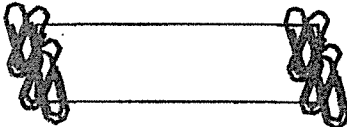

(2)

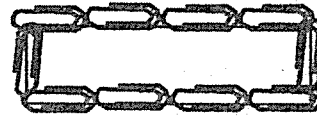

(4)

16. Which of the following objects uses magnets?

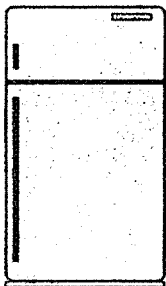

Refrigerator

(1)

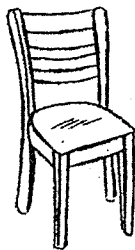

Chair

(2)

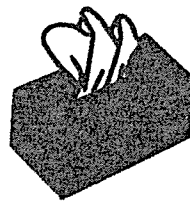

Tissue Box

(3)



Stapler

(4)

17. Three magnets are arranged in the diagram shown below. The poles are labelled.

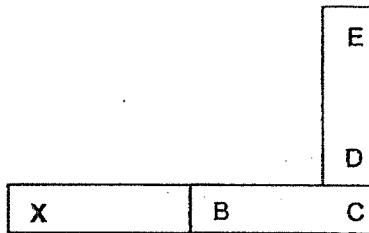

Which of the following poles will be attracted by 'X' Pole of the magnet?

- (1) B and D only (3) C and D only
(2) B and E only (4) C and E only

18. Portia placed a magnet beside a few objects as stated below.

- A: Glass rod
B: Steel spoon
C: Plastic pin
D: Aluminium rod

Which of the following objects will be attracted by the magnet?

- (1) B only (3) A and C only
(2) C only (4) B and D only



SINGAPORE CHINESE GIRLS' SCHOOL
SECOND SEMESTRAL ASSESSMENT 2022

PRIMARY 3

SCIENCE

BOOKLET B

Total Time for Booklets A and B: 1 h 25 min

Name : _____ ()

28 October 2022

Class : Primary 3 SY / C / G / SE / P

INSTRUCTIONS TO CANDIDATES

1. Do not open this booklet until you are told to do so.
2. Follow all instructions carefully.
3. Answer all questions.
4. Write your answers in this booklet.

	Max Mark	Marks attained
Booklet A	40	
Booklet B	30	
Total Marks	70	
		Percentage %

Parent's Signature

This booklet consists of 9 printed pages and 1 blank page.

Booklet B: 30 marks

For questions 21 to 28, write your answers in this booklet.

The number of marks available is shown in brackets () at the end of each question or part question.

21. Daryl placed three set-ups as shown below in a dark room.

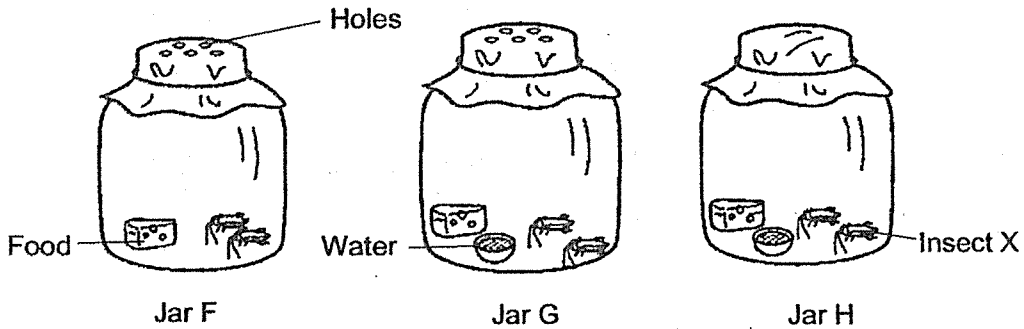

- (a) Which jar will most likely have Insect X that are still alive after a week?
Explain your answer. (2m)

- (b) When the lights of the room were switched on, all the insects made a sound.

Which characteristic of living things is shown by the observation above?
(1m)

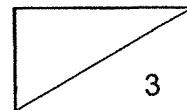

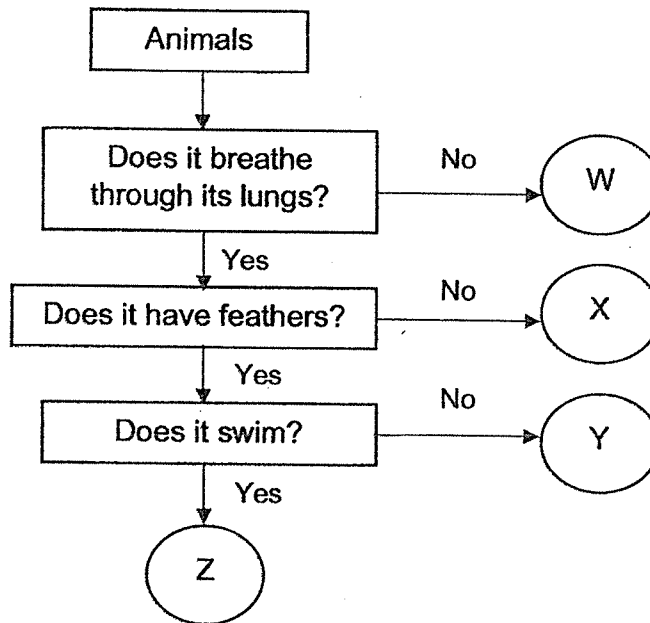

22. Look at the chart below carefully.



(a) Describe Animal X. (1m)

(b) State one difference between Animal W and Animal Y. (1m)

(c) Based on the chart above, which animals, W, X, Y or Z represents the animals below? (2m)

	
Animal _____	Animal _____

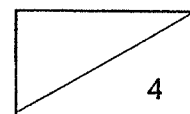

23. Grace tested three different types of wood, F, G and H, using the experiment below. The three types of wood are of the same thickness and length.

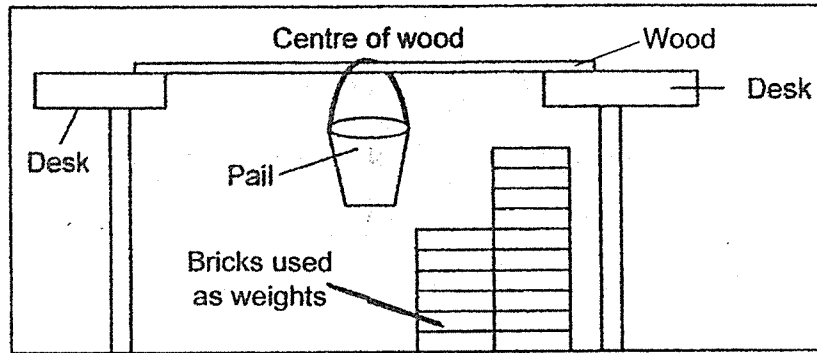

She placed the bricks into the pail one at a time until the wood broke. She repeated the experiment with different types of wood and recorded her results in the table below.

Type of Wood	Number of Bricks needed to break the Wood
F	10
G	20
H	14

- (a) Which property of the wood is she testing? (1m)

Property: _____

- (b) Grace chose Wood G to make a bookshelf. Do you agree? Explain your answer. (1m)

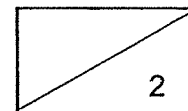

24. Jeremy set up a tent below for his outdoor camp.

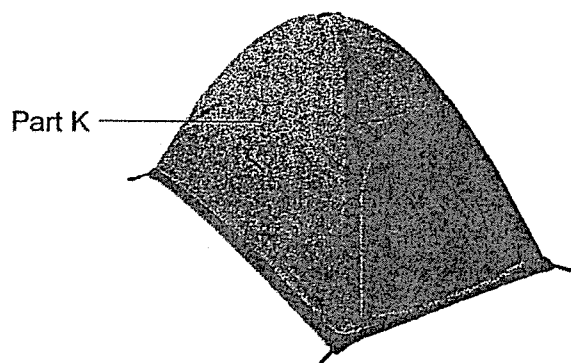

(a) Circle the material that should be used to make Part K of the tent. (1m)

Glass Wood Plastic Iron

(b) Compare the materials and give two reasons why you chose the material instead of the others above. (2m)

Reason 1: _____

Reason 2: _____

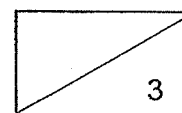

25. Different parts of the human digestive system are labelled in the diagram below.

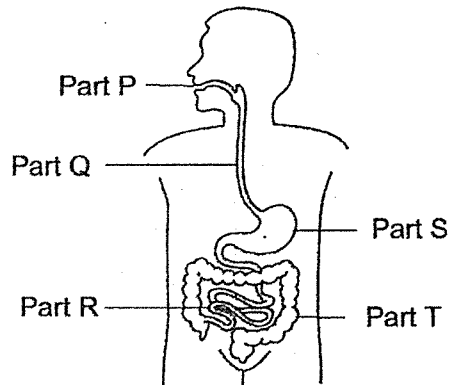

- (a) Match the parts of the digestive system (P, Q, R, S or T) to the statements below. (3m)

Statements	Parts
Food is not digested here.	_____ and _____
Digestion of food is completed here.	_____

- (b) Fill in the blank. (1m)

In Part T, is removed from the undigested food.

- (c) State the flow of food in the digestive system by filling in the boxes with Parts P, Q, R, S and T. (1m)

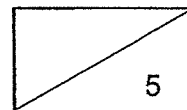
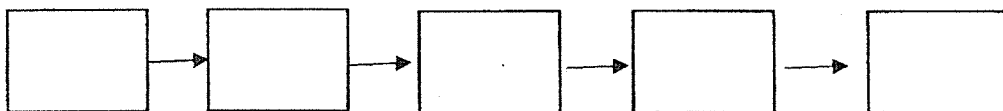

26. The diagram below shows a plant. It is watered daily.

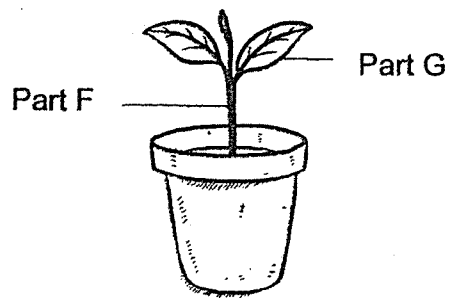

(a) Label the parts of the plant. (2m)

Part F: _____

Part G: _____

(b) What is the function of Part F? (1m)

(c) The roots of the plant above were removed.
Explain why the plant died after a few days. (2m)

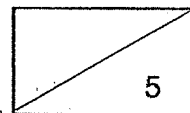

27. Kamala did two experiments using magnets.

- (a) Kamala has three different objects, A, B and C, which are made of unknown materials. She placed a magnet close to Object A and recorded her observations in the table below. She repeated the experiment with Objects B and C.

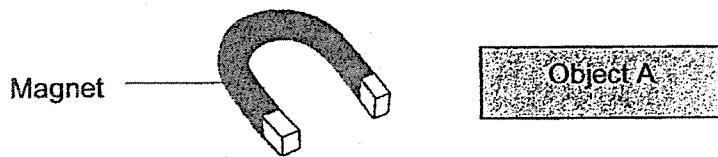

Objects	Attracted to the magnet	Repelled by the magnet
A		
B	✓	
C		✓

Which of the objects, A, B or C, could be a plastic block or steel ruler?

- (i) Plastic block: Object _____ (2m)
- (ii) Steel ruler: Object _____
- (b) Kamala then set up the second experiment with an iron toy car as shown below.

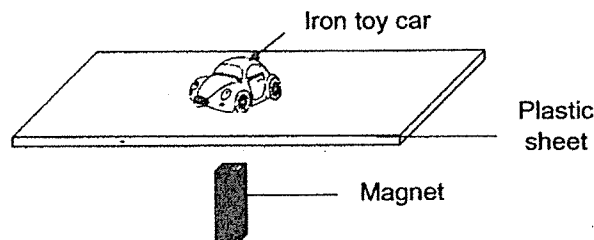

The toy car was able to move when Kamala moved a magnet under the plastic sheet. She repeated the same experiment using a wooden block, instead of a magnet.

Will the toy car be able to move? Explain your answer. (2m)

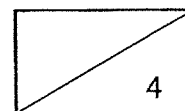

28. The diagram below shows an electromagnet placed near a box of paper clips.

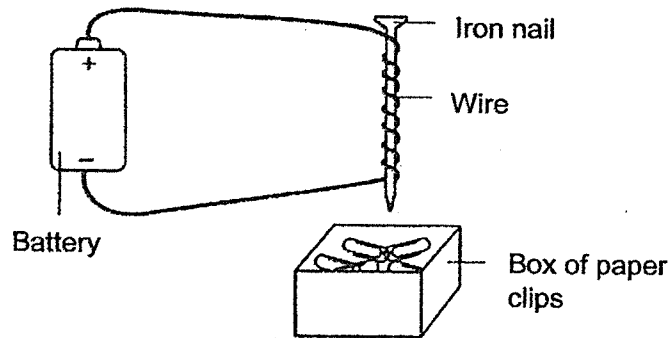

- (a) The electromagnet can attract five paper clips.

State two possible changes to make the electromagnet stronger to attract more than five paper clips. (2m)

1st change: _____

2nd change: _____

- (b) The iron nail was replaced with a silver nail and no paper clips were attracted. Explain the observation. (2m)

End of Booklet B
Please check your work.

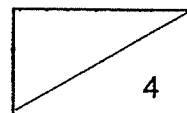

YEAR : 2022
 LEVEL : PRIMARY 3
 SCHOOL : SINGAPORE CHINESE GIRLS' SCHOOL
 SUBJECT : SCIENCE
 TERM : SECOND SEMESTRAL ASSESSMENT

(BOOKLET A)

Q1	4	Q2	3	Q3	1	Q4	2	Q5	3
Q6	2	Q7	3	Q8	2	Q9	2	Q10	4
Q11	1	Q12	1	Q13	3	Q14	4	Q15	2
Q16	1	Q17	4	Q18	1	Q19	4	Q20	3

(BOOKLET B)

Q21	(a)	Jar G. Because it has holes for air to come in so that insect X can breathe and it also has food and water for insect X to stay alive.
	(b)	Living things respond to changes around them.
Q22	(a)	Animal X breathes through its lungs and does not have feathers.
	(b)	Animal W does not breathe through its lungs but Animal Y does.
	(c)	Animal W // Animal Y
Q23	(a)	Property: Strength
	(b)	Yes. Because Wood G needed the most number of bricks to break it.
Q24	(a)	*Circle Plastic*
	(b)	Reason 1: Plastic is lighter than iron, wood and glass. Reason 2: Plastic is flexible but iron, wood and glass are not flexible.
Q25	(a)	Parts: Q and T R
	(b)	Digestive water
	(c)	P -> Q -> S -> T -> R
Q26	(a)	Part F: Stem Part G: leaves
	(b)	It holds the plant upright.
	(c)	Roots absorb water and mineral salts for the plants, thus the plant could not receive any water for survival.
Q27	(a)	(i) Object A (ii) Object B
	(b)	No. The wooden block is not a magnet so it cannot attract the toy car.
Q28	(a)	1 st change: Put more batteries 2 nd change: Coil the wire more times around the iron nail.
	(b)	Because silver is a non-magnetic material so it cannot be magnetized.