

Red Swastika School
Primary 3 Science 2022
Class Test 1

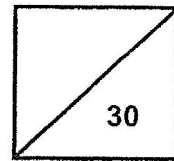

Name: _____ () Parent's Signature: _____

Class: Pr. 3 _____ Date: _____

Section A: Multiple-Choice Questions (9 x 2 = 18 marks)

Choose the most suitable answer and write its number in the brackets provided.

1. Look at the table below.

Living things	Non-living things
fire	cup
butterfly	car

Which item in the table is grouped wrongly?

- (1) fire
- (2) cup
- (3) car
- (4) butterfly

()

2. Which of the following is a characteristic of mammals?

- (1) Lay eggs
- (2) Have four legs
- (3) Have hair on their bodies
- (4) Have hard outer coverings

()

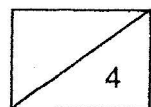

3. James spotted a bird's nest fern as shown below.

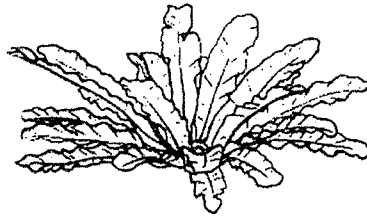

Which of the following statements about the bird's nest fern is incorrect?

- (1) It can grow.
- (2) It has leaves.
- (3) It cannot make food.
- (4) It reproduces by spores. ()

4. Study the diagrams below.

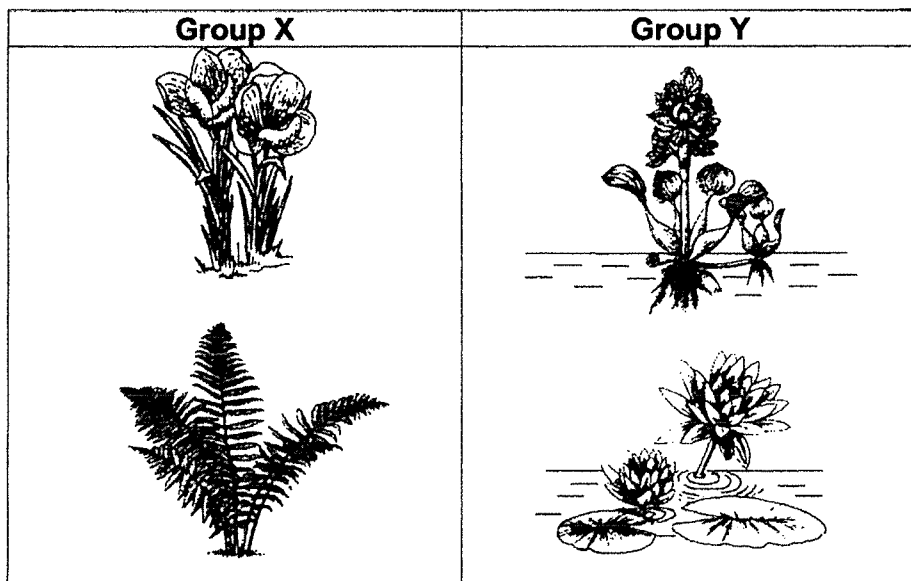

Which of the following are the most suitable headings for groups X and Y?

	Group X		Group Y
(1)	Land plants		Water plants
(2)	Flowering plants		Non-flowering plants
(3)	Non-living things		Living things
(4)	Non-flowering plants		Flowering plants

()

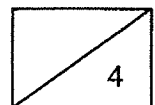

5. Rina observed that the leaves of a tree open up in the day but close up at night as shown below.

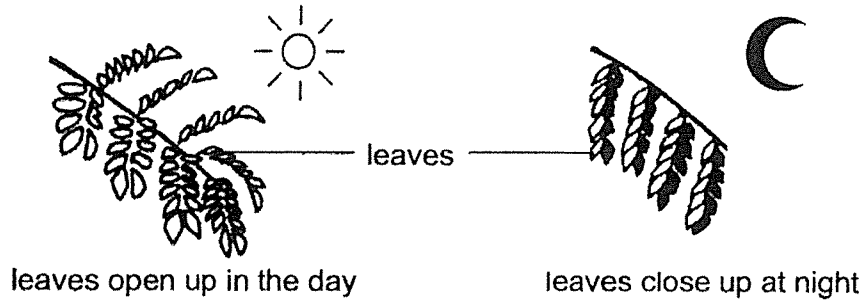

Which characteristic of living things is shown by the leaves above?

- (1) Living things can die.
- (2) Living things can grow.
- (3) Living things can reproduce.
- (4) Living things respond to changes. ()

6. Study the flowchart below.

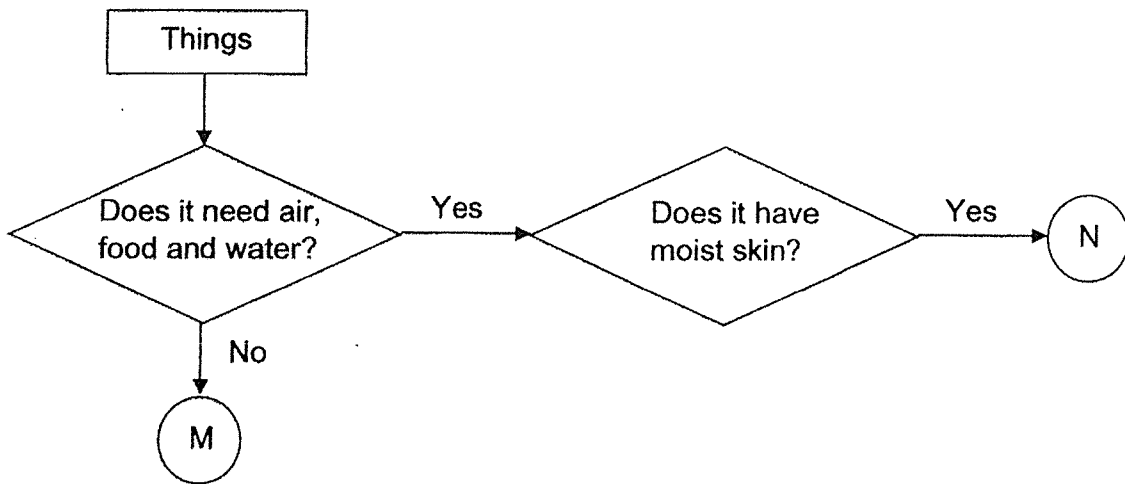

What could M and N most likely be?

	M	N
(1)	book	frog
(2)	table	fish
(3)	fish	frog
(4)	fish	book

()

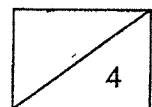

7. The table below shows the characteristics of animals A, B, C and D.

	Has dry skin	Has hair
Lives in water	A	B
Does not live in water	C	D

The diagram below shows a dolphin.

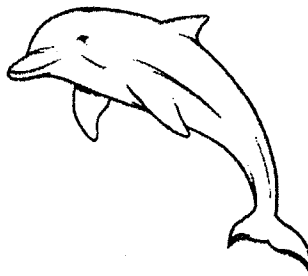

Which letter in the table above represents the dolphin?

- (1) A
- (2) B
- (3) C
- (4) D

()

8. The table below shows the characteristics of four animals, W, X, Y and Z.

Characteristics	W	X	Y	Z
Has hair		✓	✓	
Has wings	✓	✓		
Has a hard outer covering				✓

Which animal is most likely an insect?

- (1) W
- (2) X
- (3) Y
- (4) Z

()

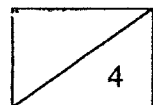

9. Nadia found four different plants, A, B, C and D. She recorded her observations of their characteristics in the table below.

Characteristics	A	B	C	D
Bears fruits	No	No	Yes	Yes
Grows on land	Yes	No	Yes	No

Using the information in the table above, Nadia wants to classify the four plants into the classification chart below.

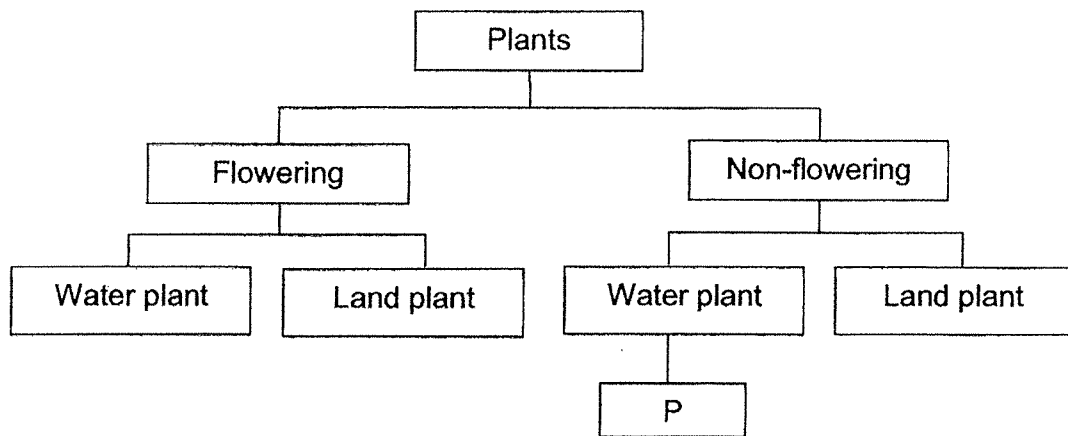

Which plant, A, B, C or D, can be classified under P?

- (1) A
- (2) B
- (3) C
- (4) D

()

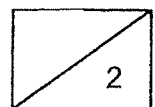

Section B: Open-ended Questions (3 x 4 = 12 marks)

10. Ahmad saw two animals, A and B, as shown below.

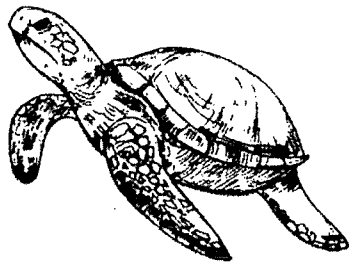

Animal A

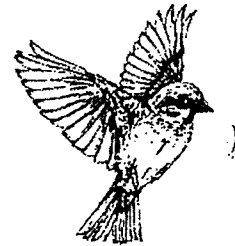

Animal B

(a) State the animal groups that animals A and B belong to. (2m)

Animal A: _____

Animal B: _____

(b) State a similarity in the way animals A and B reproduce. (1m)

(c) State a difference in the body coverings of animals A and B. (1m)

11. Gerald has a toy robot. It is able to move and respond to sounds.

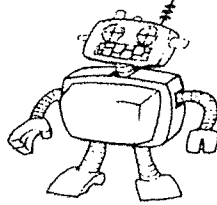

(a) However, Gerald knows that the toy robot is not a living thing. Using the characteristics of living things, state two reasons why the robot is not a living thing. (2m)

Reason 1: _____

Reason 2: _____

The table below shows the characteristics of two animals, M and N.

Characteristics	M	N
Gives birth to young alive	✓	
Has three body parts		✓
Lives on land		✓
Lives in water	✓	

(b) Based on the information above, write M and N into the correct boxes in the classification chart below. (2m)

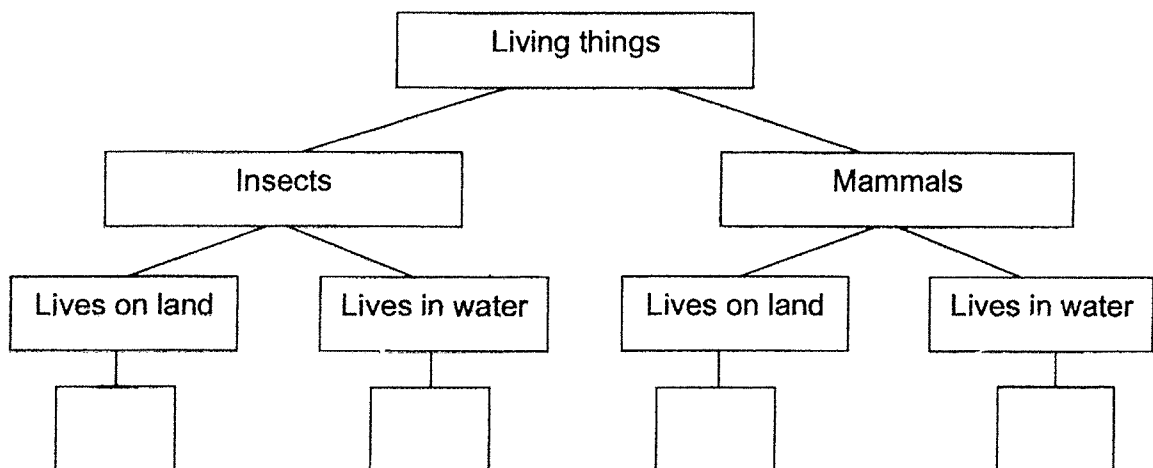

12. Study the diagram of the plant below.

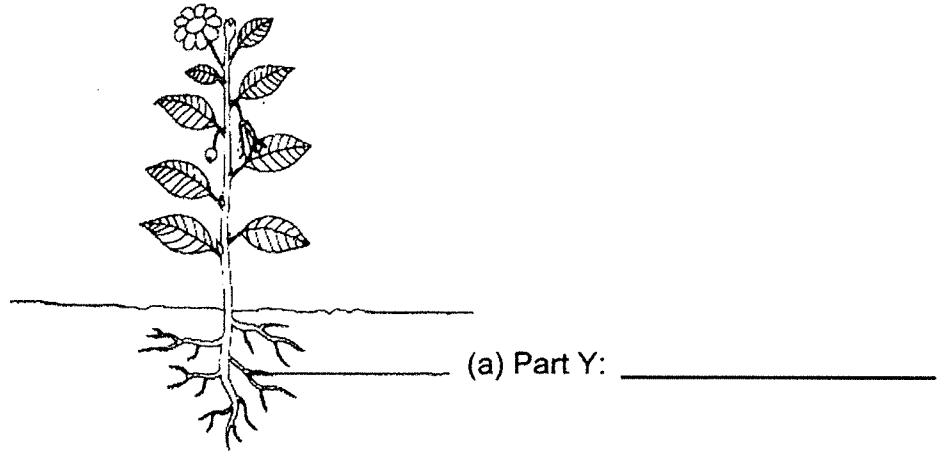

(a) Name part Y of the plant above. (1m)

(b) How does the plant above reproduce? (1m)

Ashley placed four similar plants, A, B, C and D, under different conditions as shown in the table below.

	A	B	C	D
Plant was watered daily	Yes	Yes	No	No
Place where plant was left	Garden	Inside a dark cupboard	Garden	Inside a dark cupboard

(c) Predict which plant is likely to die first. (1m)

(d) Give a reason for your answer in (c). (1m)

End of Paper

Please check your answer.

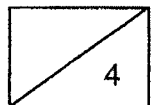

Red Swastika School
Primary 3 Science 2022
Class Test 2

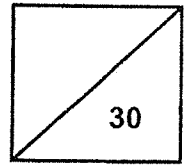

Name: _____ () Parent's Signature: _____

Class: Pr. 3 _____ Date: _____

Section A: Multiple-Choice Questions (9 x 2 = 18 marks)

Choose the most suitable answer and write its number in the brackets provided.

1. The diagram below shows a park.

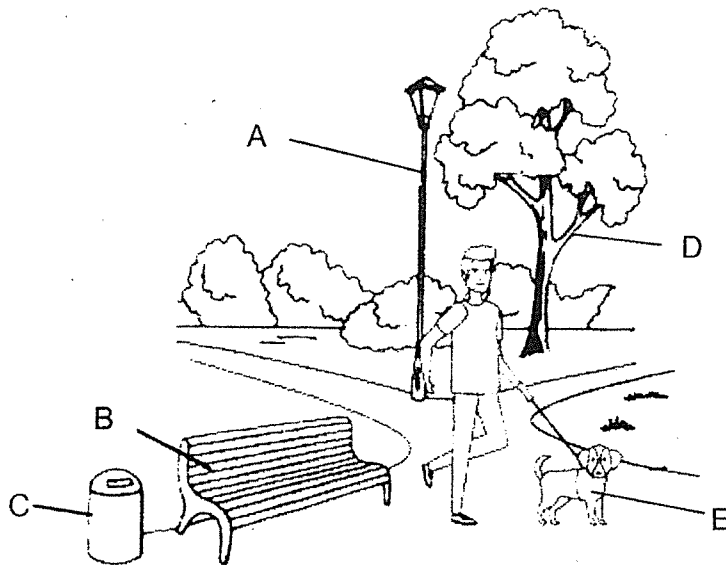

Which of the following things need air, food and water to survive?

- (1) D only
- (2) D and E only
- (3) B, C and D only
- (4) A, D and E only

()

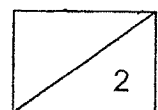

2. Adriel kept two fish in a fish tank. He fed the fish every day and did not add in any new fish to the tank. He noticed that the number of fish increased after a few weeks.

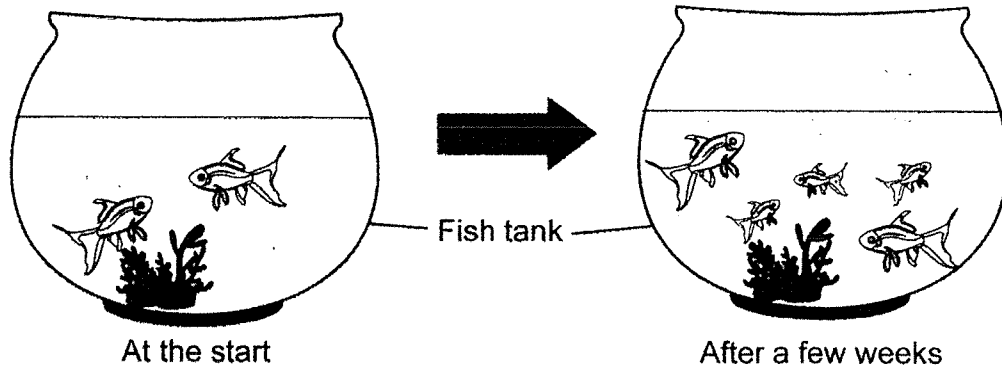

Why did the number of fish increase?

- (1) The fish reproduced.
- (2) The fish grew in size.
- (3) The fish fed on other fish.
- (4) The fish responded to changes. ()

3. Look at the pictures of the living things, A and B, shown below.

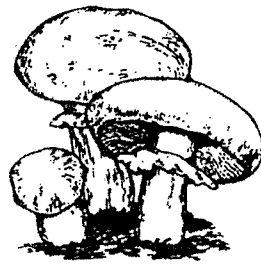

A



B

Which of the following statements about A and B are true?

- A Both can grow.
- B Both can reproduce.
- C Both can make their own food.

- (1) A and C only
- (2) A and B only
- (3) B and C only
- (4) A, B and C ()

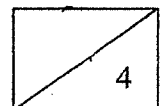

4. Which of the following are true about bacteria?

- A Bacteria can reproduce.
- B Bacteria can make their own food.
- C Bacteria can only be seen with a microscope.
- D Bacteria respond to changes in the surrounding.

- (1) A and B only
- (2) B and C only
- (3) A, B and C only
- (4) A, C and D only

()

5. Jiayi wanted to carry out an experiment to find out if plants need water to grow. She used two identical pots of plants, X and Y, for her experiment. The conditions for Pot X are shown in the table below.



Pot X



Pot Y

	Pot X	Pot Y
Amount of water (ml)	100	?
Number of hours in the sun daily	5	?

Which of the following conditions should Jiayi use for Pot Y so as to conduct a fair experiment?

	Amount of water (ml)	Number of hours in the sun daily
(1)	100	5
(2)	100	3
(3)	0	5
(4)	0	3

()

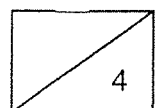

6. Dave kept the same number of beetles in four tanks, A, B, C and D, as shown in the diagram below. The beetles were left in the tanks for three weeks.

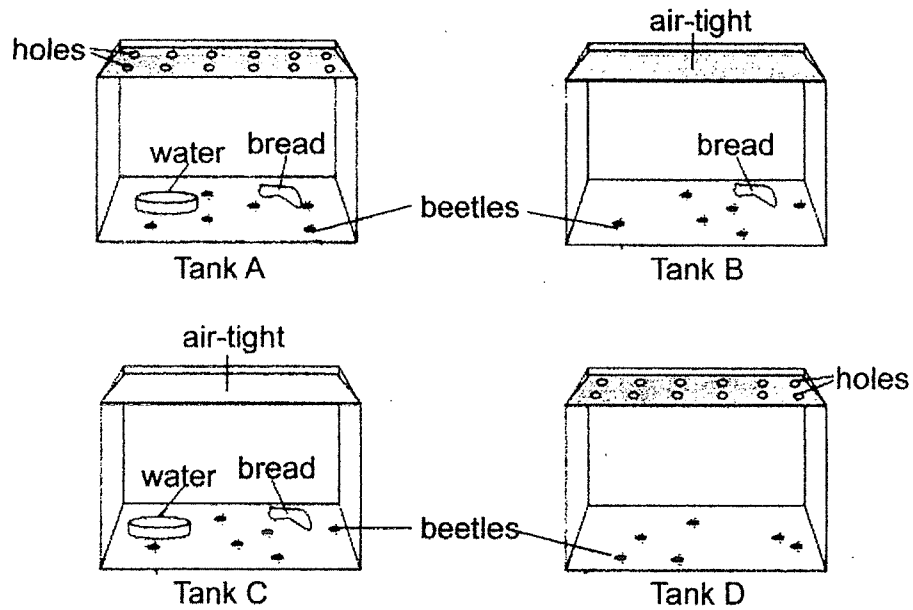

Which tank would have the greatest number of beetles alive after three weeks?

- (1) Tank A
- (2) Tank B
- (3) Tank C
- (4) Tank D

()

7. Jon observed an animal.



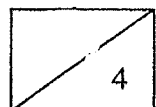

Which one of the following pair of observations would help Jon conclude that the animal is a mammal or a reptile?

	Mammal	Reptile
(1)	Found on land	Found in water
(2)	Has two legs	Has four legs
(3)	Gives birth	Lays eggs
(4)	Feeds on both plants and animals	Feeds on animals only

()



8. Some objects are classified into two groups, X and Y, as shown below.

Group X		Group Y	
			
paper towel	rubber floor mat	glass mug	metal spoon

Which of the following are the most suitable headings for groups X and Y?

	Group X	Group Y
(1)	Flexible	Not flexible
(2)	Breaks easily	Does not break easily
(3)	Floats on water	Sinks in water
(4)	Allows light to pass through	Does not allow light to pass through ()

9. Meiling wanted to find out the strength of materials W, X, Y and Z. She placed identical weights on the material, as shown in the set-up below. The materials were of the same size, thickness and shape.

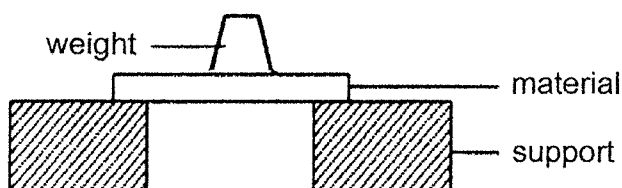

She recorded the number of weights needed to break each material in the table below.

Material	Number of weights needed to break the material
W	20
X	3
Y	8
Z	15

What could be a possible conclusion based on the results in the table above?

- (1) W is the weakest material.
- (2) X is the strongest material.
- (3) Y is weaker than X.
- (4) Z is stronger than Y.

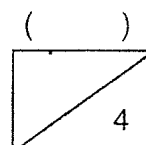

Section B: Open-ended Questions (3 x 4 = 12 marks)

10. Sarvesh went to the zoo. He observed two animals, P and Q, and recorded his observations in the table below.

Observation	Animal P	Animal Q
It breathes through gills.	Yes	No
Its body is covered with scales.	Yes	Yes

(a) Based on the information above, name the two animal groups that animals P and Q most likely belong to. (2m)

(i) Animal P: _____

(ii) Animal Q: _____

Sarvesh concluded that a frog, as shown below, does not belong to the same group as Animal Q.

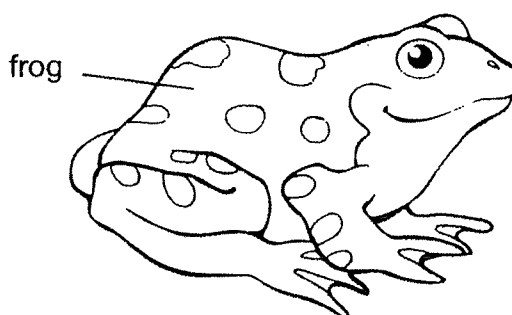

(b) Which animal group does the frog belong to? Why do you say so? (2m)

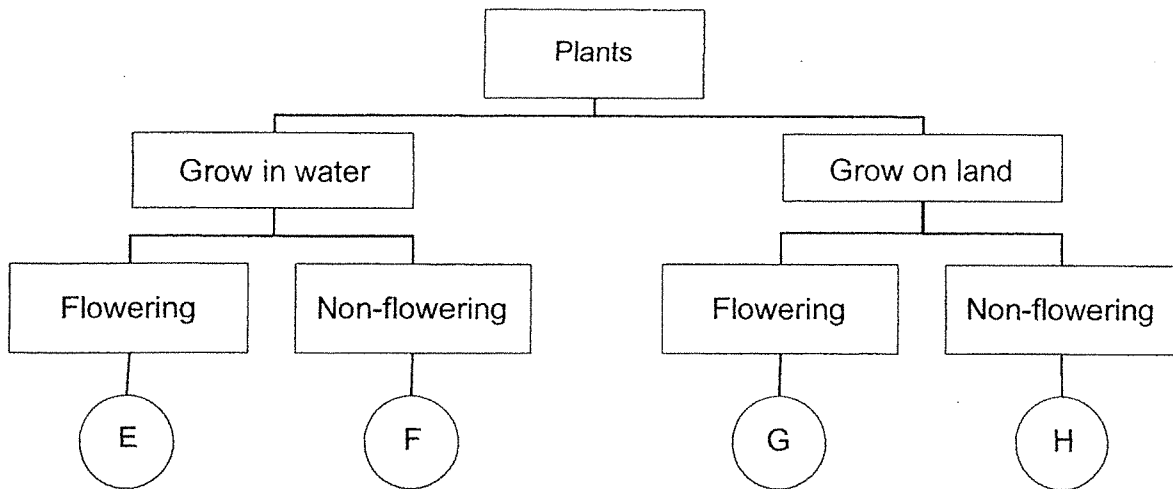

11. Study the classification chart below. E, F, G and H represent four different types of plants.



- (a) Based on the classification chart, state one similarity between plants E and G. (1m)

- (b) Based on the classification chart, state one difference between plants F and H. (1m)

- (c) Based on the classification chart, which letter, E, F, G or H, best represents each of the following plants? (2m)

Plant	Letter
 Fern	
 Hibiscus plant	

12. Study the flowchart below carefully. A, B and C represent three different types of materials.

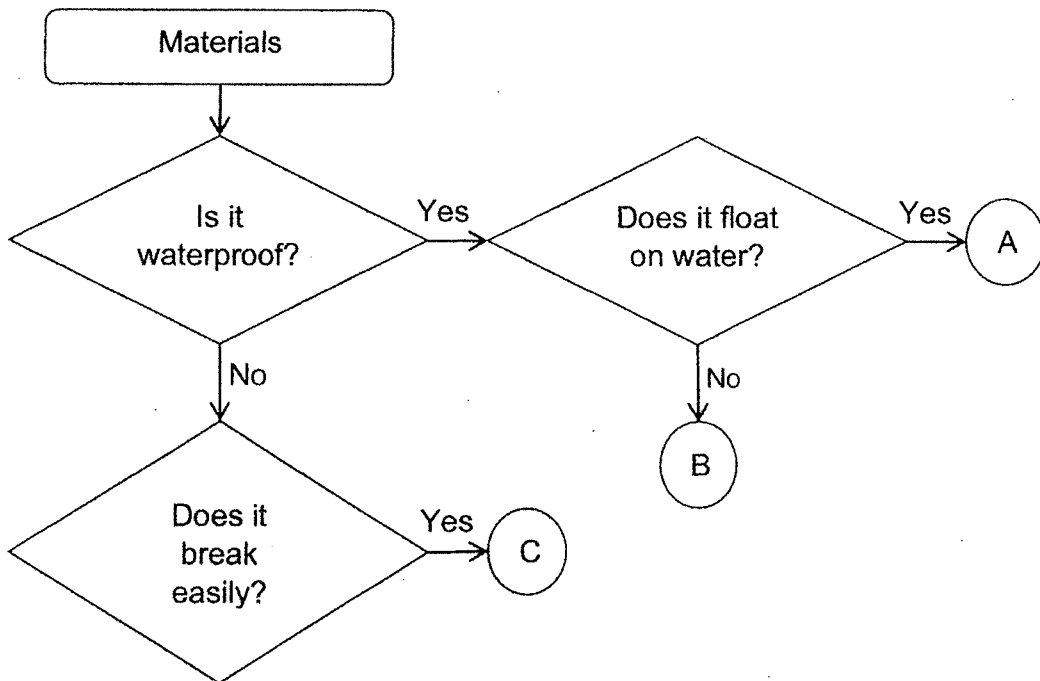

- (a) Based on the flowchart, state the two properties of Material C. (2m)

The diagram below shows Lina learning how to swim with a kickboard.

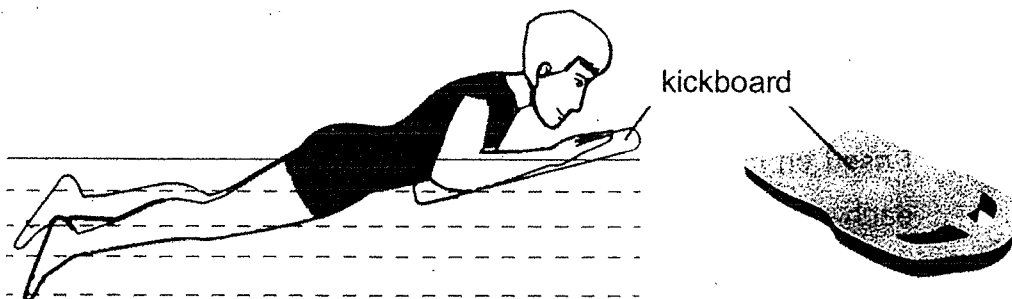

- (b) Based on the flowchart, which material, A, B or C, is most suitable for making the kickboard? Explain why. (2m)

End of Paper

Please check your answer.

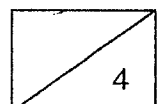

**Red Swastika School
Primary 3 Science 2022
Revision Paper 1**





Name: _____ ()

Class : P3 _____

Date: _____

For Questions 1 to 15, choose the most suitable answer and shade its number in the OAS provided.

1. Study the table below.

Living things	Non-living things
 <p data-bbox="539 1019 598 1057">frog</p>  <p data-bbox="507 1281 630 1319">housefly</p>	 <p data-bbox="1082 1019 1152 1057">keys</p>  <p data-bbox="1056 1281 1173 1319">hibiscus</p>

Which one of the above was classified wrongly?

- (1) frog
- (2) keys
- (3) housefly
- (4) hibiscus

2. Which of the following has hair as its outer body covering?

- (1) insect
- (2) reptile
- (3) mammal
- (4) amphibian

3. Study the diagram of plant X shown below.

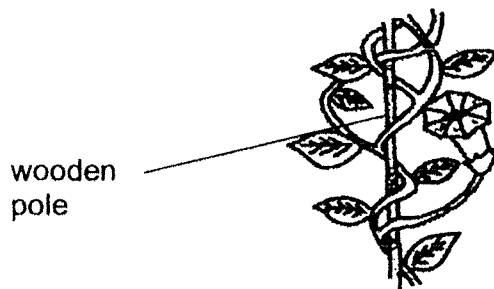

Plant X needs a wooden pole for support because it _____.

- A: has a weak stem
 - B: needs to absorb more water
 - C: needs to reach up for more sunlight
- (1) A only
 - (2) A and C only
 - (3) B and C only
 - (4) A and B only

4. The table below shows the characteristics of four animals.

Characteristics	has six legs	has feathers	feeds its young with milk
bird	x	✓	x
fish	✓	x	x
insect	✓	x	✓
mammal	x	✓	✓

Which one of the following animals in the table is correctly described?

- (1) bird
 - (2) fish
 - (3) insect
 - (4) mammal
5. Which of the following organs is not part of the human respiratory system?
- (1) nose
 - (2) lungs
 - (3) heart
 - (4) windpipe

6. The diagram below shows one of the human body systems.

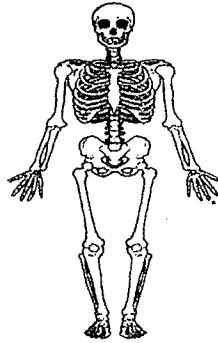

Some students shared statements about this human body system.

Abu:	It helps to give us shape.
Ben:	It helps to support our body.
Caela:	It helps to protect the important organs in our body.
David:	It helps to transport food and water to all parts of our body.

Which student made an incorrect statement?

- (1) Abu
- (2) Ben
- (3) Caela
- (4) David

7. The diagram below shows a plant.

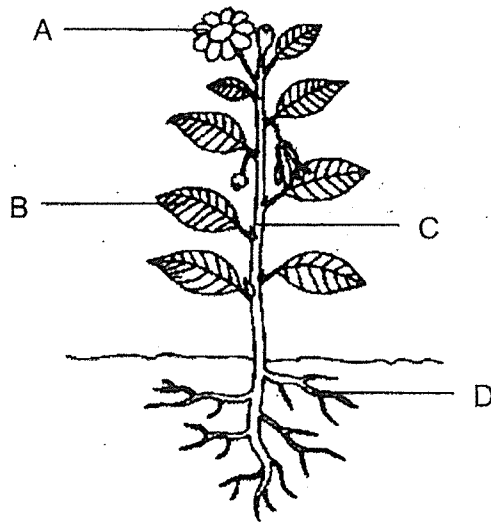

Which part of the plant, A, B, C or D, helps to hold the plant firmly to the ground?

- (1) A
- (2) B
- (3) C
- (4) D

8. The diagram below shows one of the organs in the human digestive system.

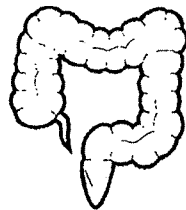

Which of the following information about the organ is correct?

	Organ	Digestion of food takes place here	Water is absorbed
(1)	Small Intestine	Yes	No
(2)	Small Intestine	No	Yes
(3)	Large Intestine	No	Yes
(4)	Large Intestine	Yes	No

9. Study the flow chart below.

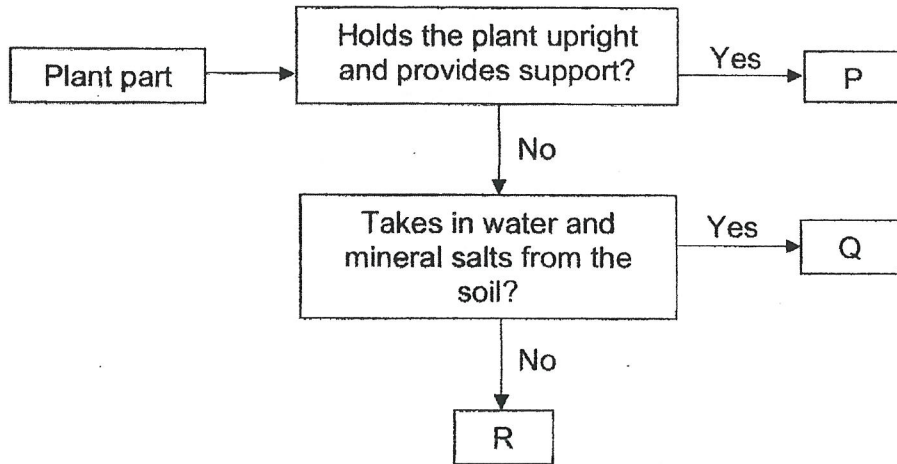

Which parts of a plant do P, Q and R represent?

	P	Q	R
(1)	stem	root	leaf
(2)	root	stem	leaf
(3)	stem	leaf	root
(4)	leaf	stem	root

10. The diagram shows a measuring tape. The measuring tape is used to measure the lengths of different objects.

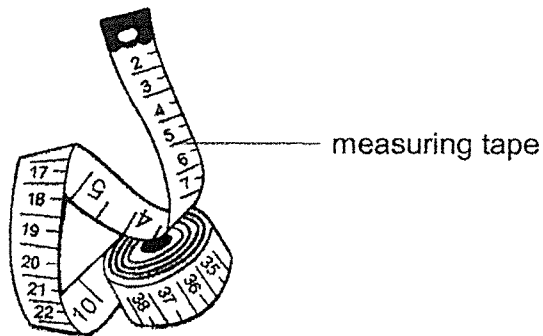

The table below shows the properties of four materials, A, B, C and D. A tick (✓) indicates that the material has the property and a cross (×) indicates that the material does not have that property.

Material	Strong	Flexible
A	✓	✓
B	×	✓
C	×	×
D	✓	×

Based on the properties shown above, which material is most suitable to make the measuring tape?

- (1) A
- (2) B
- (3) C
- (4) D

11. Susan hung metal clips to the poles of each magnet until the last clip could not be hung any more. The diagrams below show the results of her experiment.

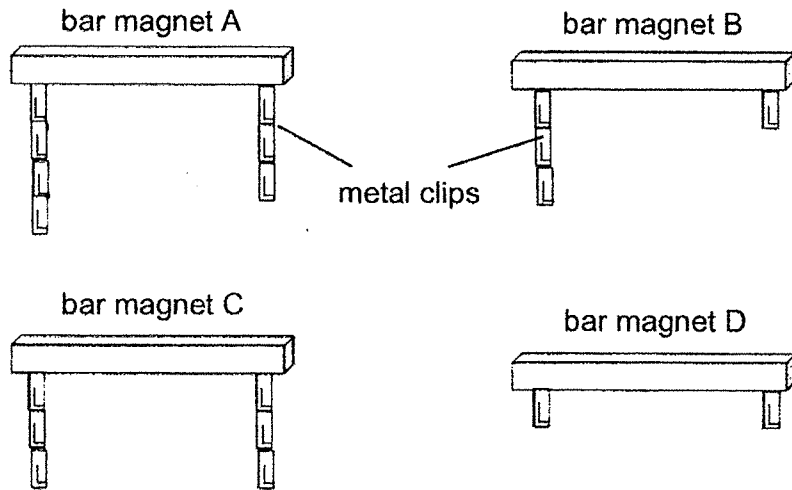

Which bar magnet has the weakest magnetic strength?

- (1) A
 - (2) B
 - (3) C
 - (4) D
12. Leah hung a magnet as shown in the diagram below. She gave the magnet a gentle push. The magnet turned and eventually stopped.

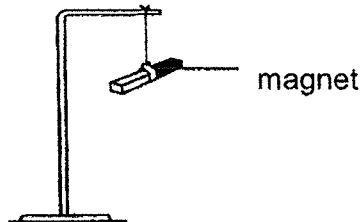

In which direction would the magnet come to a rest?

- (1) east-west
- (2) north-east
- (3) south-west
- (4) north-south

- 13 Jun Hong wanted to turn an iron nail into a temporary magnet. He used a bar magnet to stroke the iron nail in the same direction repeatedly as shown in the diagram.

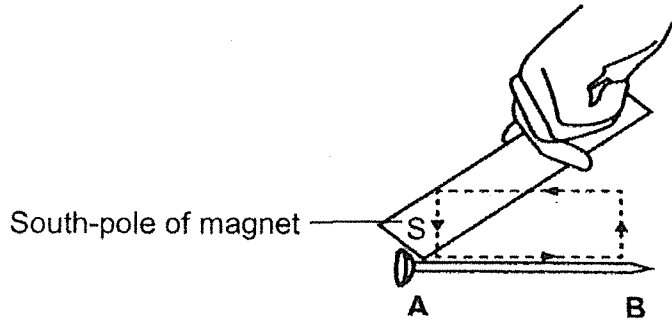

What will the poles of the temporary magnet be at points A and B?

	A	B
(1)	North	North
(2)	South	North
(3)	South	South
(4)	North	South

14. Linda placed two bar magnets next to each other. She drew four observations as seen in the diagrams below. She indicated the North-pole of the magnet with the letter 'N'. The arrows show the movement of the magnets towards or away from each other.

Which of the following diagrams shows the correct observation?

- (1)
- (2)
- (3)
- (4)

15. Shaun wanted to find out if the number of coils around an iron rod would affect the strength of the electromagnet. He set up the experiment as shown in the diagram below.

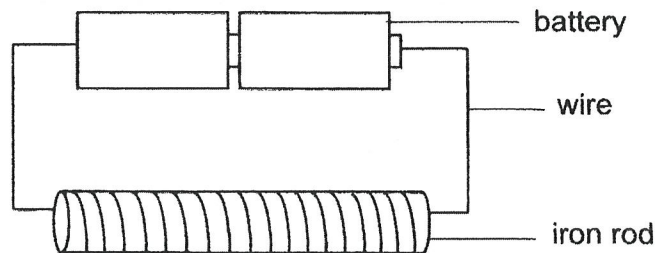

Shaun repeated the experiment with three other set-ups with different number of coils around the iron rod. He recorded the results in the table below.

Set-up	Number of pins attracted to the iron rod
P	13
Q	17
R	5
S	8

Which set-up likely had the most number of coils around the iron rod?

- (1) P
- (2) Q
- (3) R
- (4) S

**Red Swastika School
Primary 3 Science 2022
Revision Paper 2**

Name: _____ ()

Class : P3 _____

Date: _____

Answer all questions in the space provided.

16. Organisms A, B, C and D have been classified as shown below.

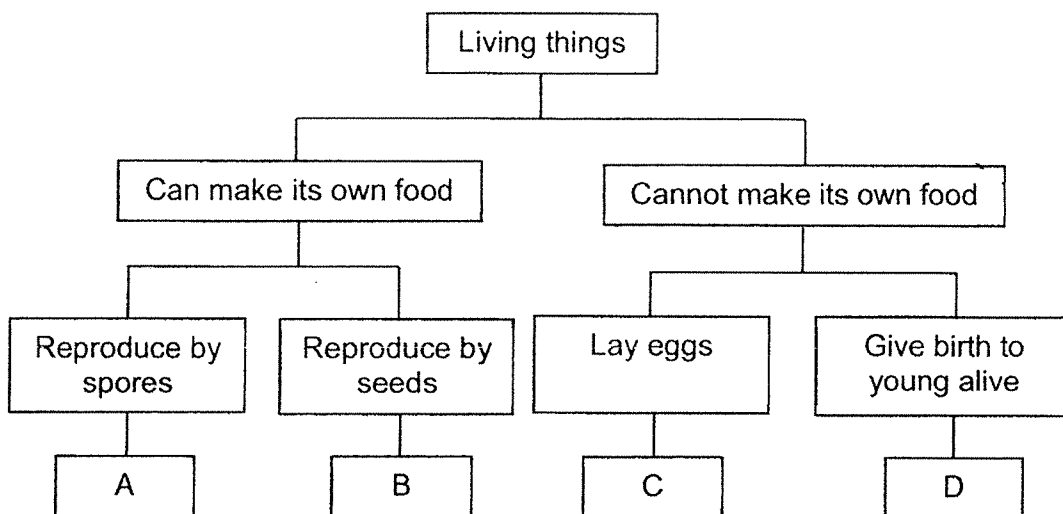

(a) Based on the classification chart, state one similarity between C and D. (1m)

(b) Which group of living things do A and B most likely belong to? (1m)

(c) Classify these organisms according to the classification chart. Fill in the blanks with the letters A, B, C or D. (2m)

Organism	Letter (A, B, C or D)
Bird's nest fern	
Elephant	

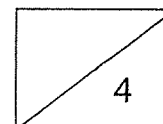

17. Study the organ system below.

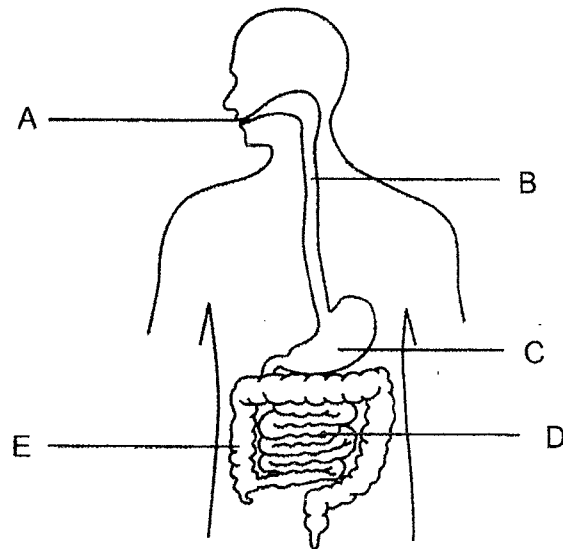

- (a) Which organs, A, B, C, D or E, produce digestive juices?
Put a tick (✓) if digestive juices are produced in the organ. You may tick more than one organ. (1m)

Organ	A	B	C	D	E
Digestive juices produced					

- (b) Read the statements below. Write 'True' or 'False' in the correct boxes. (2m)

	Statements	True or False
(i)	Digestion starts in part B.	
(ii)	Digestion ends in part C.	
(iii)	Digested food passes through the walls of part D.	
(iv)	Undigested food in part E will pass out through the anus.	

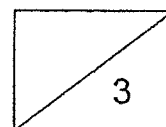

18. The diagram below shows a plant.

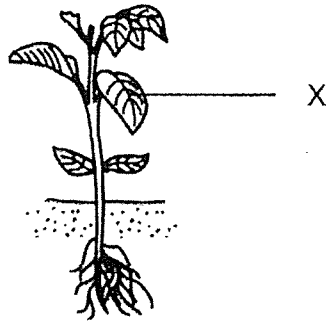

(a) State one function of part X of the plant? (1m)

Part of the plant was removed as shown in the diagram below. After a few days, the plant died.

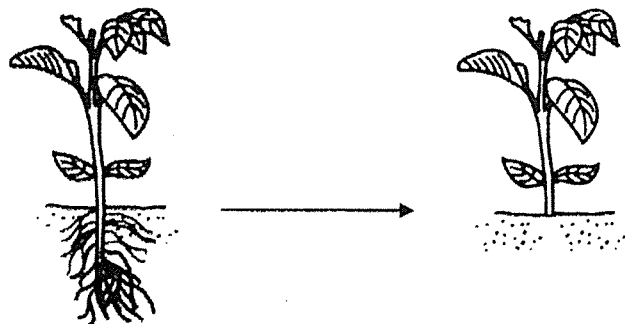

Before plant part was removed

After plant part was removed

(b) Which part of the plant was removed? (1m)

(c) Explain how the removal of the plant part caused the plant to die. (1m)

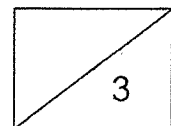

19. The table below shows the properties of four materials, A, B, C and D. A tick (✓) indicates that the material has the property and a cross (×) indicates that the material does not have the property.

Material	Flexible	Allows light to pass through
A	✓	✓
B	✓	×
C	×	✓
D	×	×

Chris wanted to make a fish tank as seen in the picture below.

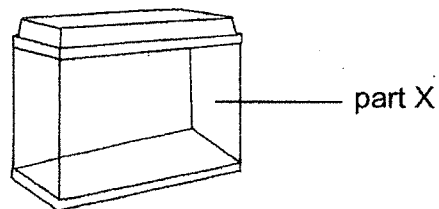

- (a) Based on the table, which material, A, B, C or D is most suitable to make part X of the tank? (1m)

- (b) Explain your answer for part (a). (1m)

- (c) Chris placed material D into a container of water. She observed the following as shown in the diagram below.



- Based on the diagram, which property of material can you tell about material D? (1m)

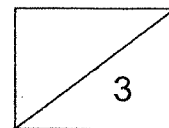

20. Leanne placed a magnet close to three objects made of different materials. An example of the set-up is shown below.

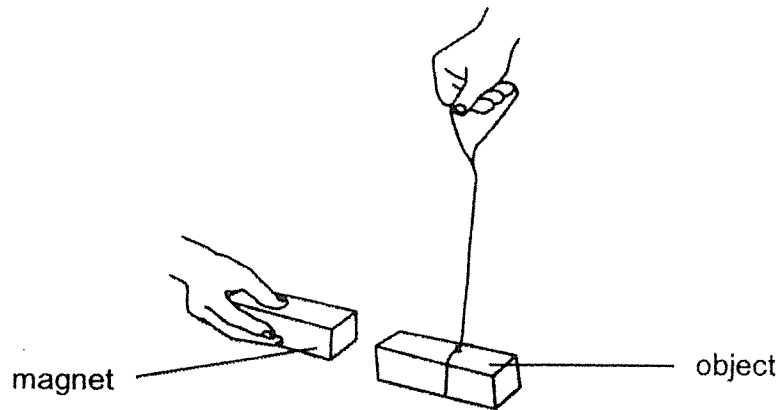

She moved the magnet slowly towards the objects. Then, she recorded her observations in the table as shown.

Objects	Observations	
	when facing north-pole of the magnet	when facing south-pole of the magnet
A	moved towards the magnet	moved towards the magnet
B	moved away from the magnet	moved towards the magnet
C	did not move	did not move

- (a) Which object, A, B or C, is likely to be a magnet? (1m)

- (b) Explain your answer in part (a). (1m)

- (c) Give an example of a material that object C can be made of. (1m)

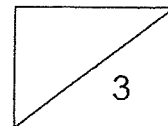

21. Min Yan conducted an experiment to find out which magnet (A, B, C or D) has the greatest magnetic strength. She set up the experiment as shown below.

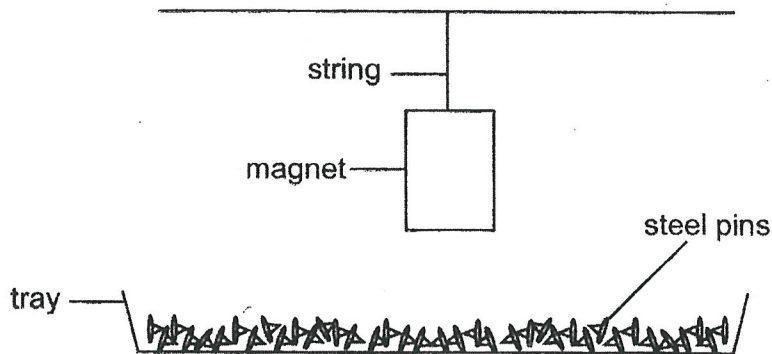

She hung magnets A, B, C and D from the same height and recorded the number of steel pins the magnet attracted in the table below.

Magnet	Number of steel pins attracted
A	5
B	13
C	16
D	9

- (a) Based on the table above, arrange the magnets according to their magnetic strength. Write the letters A, B, C and D in the correct boxes below. (1m)

(i) , (ii) , (iii) , (iv)

weakest \longrightarrow strongest

- (b) Without adding or removing anything from the set-up, what can Min Yan do to make the magnets attract more steel pins? (1m)

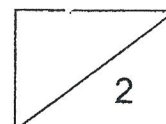

22. Min Yan wanted to find out if the number of strokes would affect the strength of the temporary magnet. She stroked an iron bar using a magnet repeatedly in the same direction as shown in the diagram below.

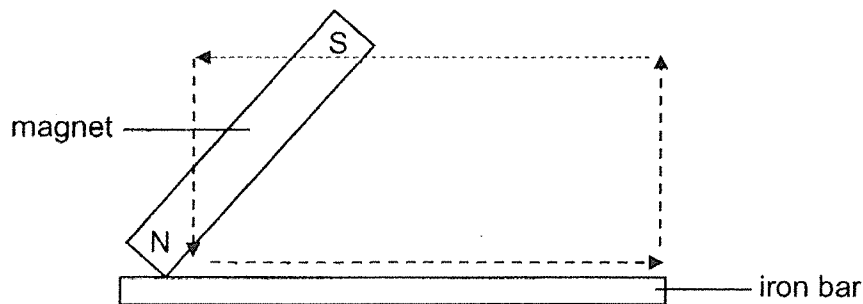

Min Yan then placed the temporary magnet over some steel pins to see how many steel pins the temporary magnet attracted. She recorded her results in the graph below.

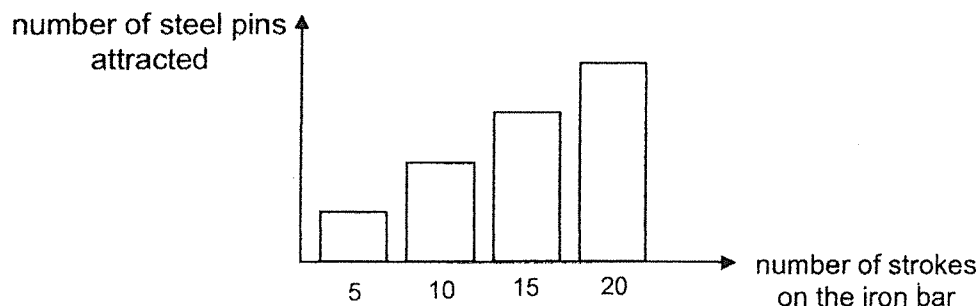

- a) Based on the graph, what is the relationship between the number of strokes on the iron bar and the number of steel pins attracted? (1m)

- b) Min Yan repeated the experiment with an aluminium bar instead. She found that she was not able to attract any steel pins. Why is this so? (1m)

End of Booklet B
Please check your answers

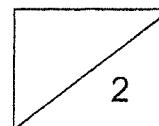



ANSWER KEY

SCHOOL : RED SWASTIKA SCHOOL
LEVEL : Primary 3
TERM : Class Test 1
SUBJECT : Science
YEAR : 2022

Q1	1	Q2	3	Q3	3	Q4	1	Q5	4
Q6	1	Q7	2	Q8	4	Q9	2		

Q10	a) Animal A: reptile Animal B: bird
	b) Animal A and Animal B reproduce by laying eggs.
	c) Animal A outer covering is dry skin with scales but Animal B out covering are feathers.
Q11	a) Reason 1: It does not need air, food and water Reason 2: It will not die
	b) Insects, lives on land: N Mammals, lives in water: M
Q12	a) Roots
	b) It reproduces by seeds.
	c) Plant D will die first
	d) D did not receive water to make food.

ANSWER KEY

SCHOOL : RED SWASTIKA SCHOOL
LEVEL : Primary 3
TERM : Class Test 2
SUBJECT : Science
YEAR : 2022

Q1	2	Q2	1	Q3	2	Q4	4	Q5	3
Q6	1	Q7	3	Q8	1	Q9	4		

Q10	a) i) Animal P : Fish ii) Animal Q : Reptile b) The frog belongs to the group amphibians because frogs have moist skin and can live on land and water
Q11	a) Plant E and G are flowering plants. b) Plant F grows in water but plant H grow on land. c) Fern: H Hibiscus plant : G
Q12	a) Material C is not waterproof and break easily. b) A. A can float on water. A kickboard must float so that Lina can hold on without sinking.

ANSWER KEY

SCHOOL : RED SWASTIKA SCHOOL
LEVEL : Primary 3
TERM : Revision Paper 1
SUBJECT : Science
YEAR : 2022

Q1	4	Q2	3	Q3	2	Q4	1	Q5	3
Q6	4	Q7	4	Q8	3	Q9	1	Q10	1
Q11	4	Q12	4	Q13	2	Q14	3	Q15	2

ANSWER KEY

SCHOOL : RED SWASTIKA SCHOOL
 LEVEL : Primary 3
 TERM : Revision Paper 2
 SUBJECT : Science
 YEAR : 2022

Q16	a) They both cannot make its own food.
	b) A and B are plants.
	c) Bird's nest fern : A Elephant : D
Q17	a) A, C, D
	b)
	i) F
	ii) F
	iii) T
iv) T	
Q18	a) The function of part X is to make food for the plant.
	b) Roots was removed from the plant.
	c) The removal of the plant part caused the plant to die because the roots helps to absorb water and mineral so when it was removed it could not absorb water or mineral so the plant die of not having any water or mineral
Q19	a) The most suitable material to make part X is C.
	b) Because C is not flexible and allows light to pass through.
	c) It sinks in water

Q20a)	B is likely to be a magnet.
Q20b)	B is repelled by magnet. It means their like poles are facing each other. So both are magnet.
Q20c)	An example of a material that object C can be made of is copper.
Q21a)	A, D, B, C
Q21b)	Put the magnet closer to the steel pin.
Q22a)	As the number of strokes on the iron bar increases, the number of steel pins attracted also increases.
Q22d) b	Aluminium bar cannot attract any steel pins because it is not a magnetic material.