



NANYANG PRIMARY SCHOOL

**2022
PRIMARY 3
END-OF-YEAR EXAMINATION**

**SCIENCE
(BOOKLET A)**

Total Time for Booklets A and B: 1 h 30 min

INSTRUCTIONS TO CANDIDATES

1. Write your name and index number in the space provided.
2. Do not open this booklet until you are told to do so.
3. Follow all instructions carefully.
4. Answer all questions.
5. For each question from 1 to 22, four options are given.
Indicate your choice in this booklet.
Shade the correct oval (1, 2, 3 or 4) on the Optical Answer Sheet provided.

Name: _____ ()







Class: Primary 3 ()

Booklet A consists of 17 printed pages excluding this cover page.

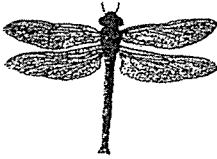

Section A: Multiple Choice Questions [44 marks]

1. Study the classification table below.

Group P		Group Q	
 dragonfly		 robot dog	
 mushroom	 cactus	 cake	 alarm clock

Which of the following **cannot** be used as headings for Group P and Group Q?

	Group P	Group Q
(1)	Can grow	Cannot grow
(2)	Can reproduce their own kind	Cannot reproduce their own kind
(3)	Cannot respond to changes around them	Can respond to changes around them
(4)	Need air, food and water to stay alive	Does not need air, food and water to stay alive

2. Edmund found plant R in his garden. Plant R has brown spores on the underside of the leaves as shown in the diagram below.

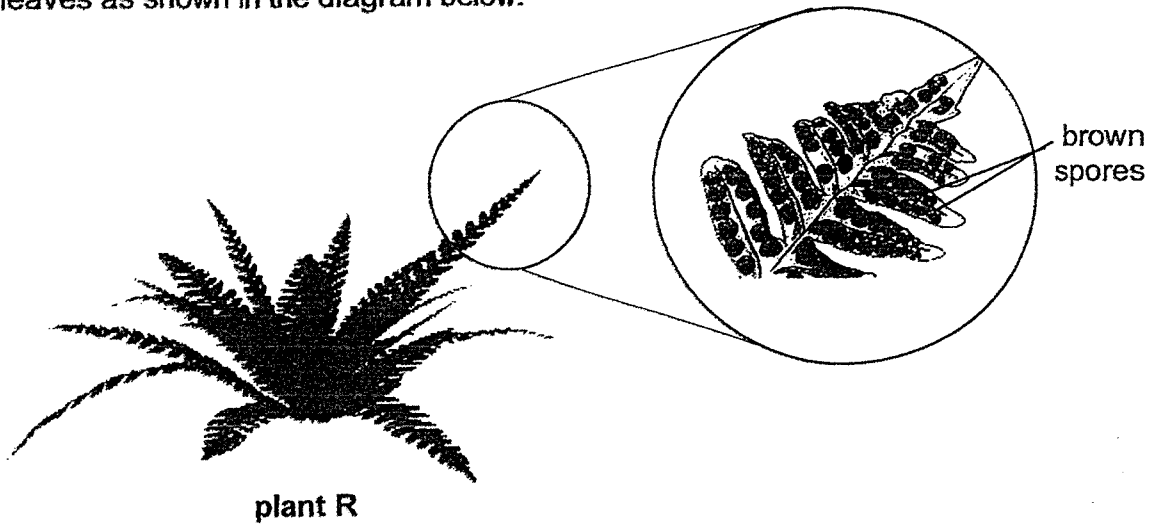

From his observation, which of the following statements about plant R are correct?

- A It is an adult plant.
- B It is a young plant.
- C It is a flowering plant.
- D It is a non-flowering plant.

- (1) A and C only
- (3) B and C only

- (2) A and D only
- (4) B and D only

3. Yi Xin was given pictures of 4 animals as shown below.

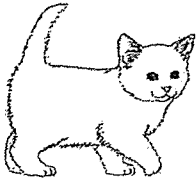

cat

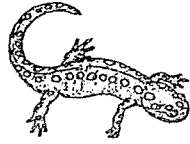

lizard



ant

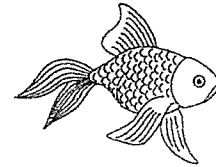

goldfish

She had to classify the 4 animals into only 2 groups.

Which one of the following headings will **not** group the 4 animals into 2 groups?

	Group P	Group Q
(1)	Give birth to young alive	Lay eggs
(2)	Have feelers	Do not have feelers
(3)	Have scales	Have hair
(4)	Live on land	Live in water

4. The diagrams below show 4 animals, A, B, C and D.



A

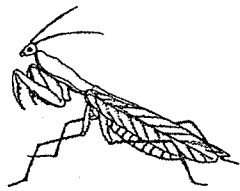

B



C

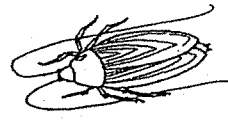

D

Based only on what can be seen from the diagrams above, which one of the following statements is correct?

- (1) All of them have 3 pair of legs.
- (2) All of them have a pair of wings.
- (3) All of them have only two body parts.
- (4) All of them have scales as their outer body coverings.

5. Study the classification diagram below.

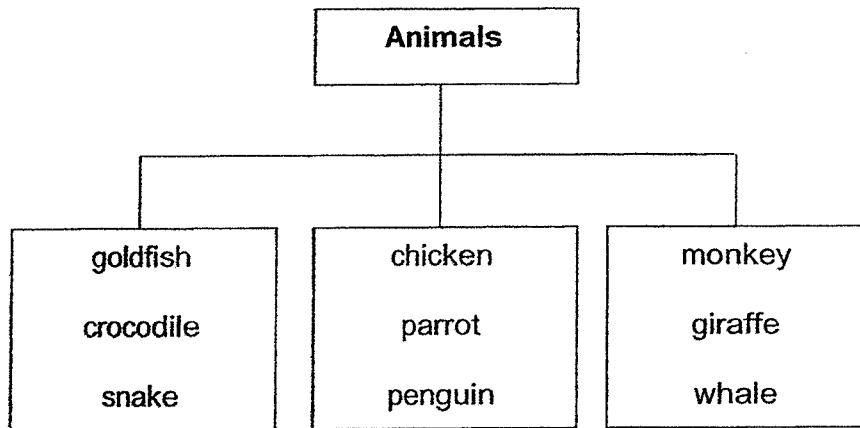

How are the animals above classified?

- (1) By the way they move
- (2) By the way they reproduce
- (3) By their outer body coverings
- (4) By the number of legs they have

6. Study the pictures below.

Which one of the following is **not** a fungi?

(1)

toadstool

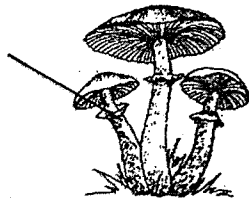

(2)

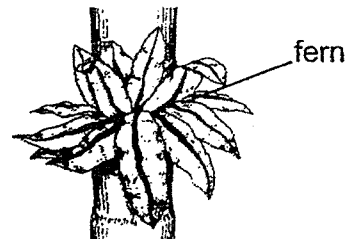

(3)

mould

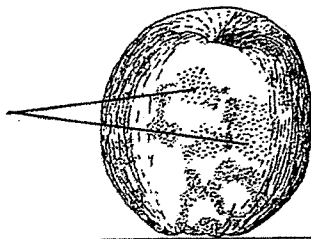

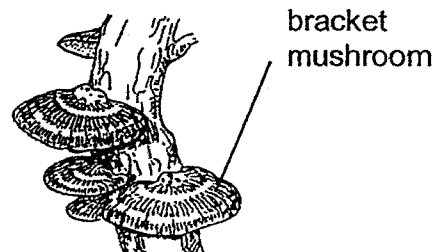

(4)



7. Jing Hao set up an experiment on bacteria Z that was growing on half-cut apples. The apples are sweet and juicy. They were placed in different locations with different temperatures.

The diagram below shows how bacteria Z has grown on the half-cut apples after three days.

Half-cut apples	 A	 B
Location	Freezer	Classroom
Temperature	0°C	30°C
Presence of air	Yes	Yes

Based on the above setups, what did Jing Hao want to find out in his experiment?

- (1) He wanted to find out if bacteria Z can be seen under a microscope.
- (2) He wanted to find out if bacteria Z needs air, food and water to grow.
- (3) He wanted to find out if bacteria Z grows better when there is warmth.
- (4) He wanted to find out if bacteria Z appears in different shapes and sizes.

8. Study the classification diagram below.

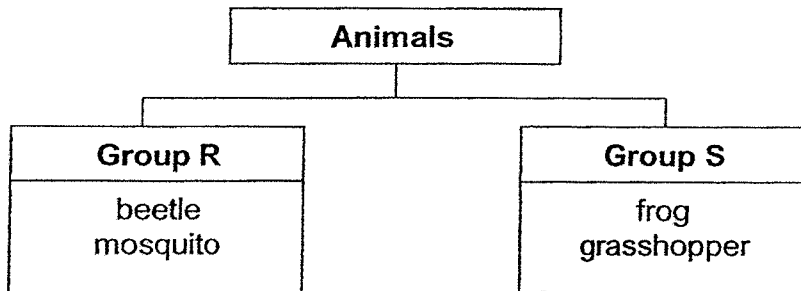

Which one of the following describes the life cycles of animals in groups R and S?

	Group R	Group S
(1)	Have an egg stage	Do not have an egg stage
(2)	4-stage life cycle	3-stage life cycle
(3)	Entire life cycle is on land	Part of the life cycle is in water
(4)	Have young that do not resemble their parents	Have young that resemble their parents

9. Study the 2 life cycles, A and B, below.

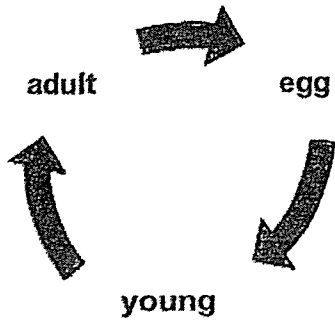

Life cycle A

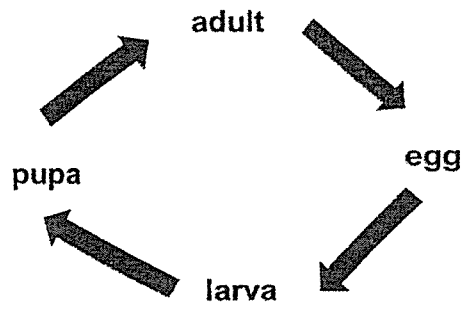

Life cycle B

Which of the following living things have the same life cycle as the above?

	Life cycle A	Life cycle B
(1)	chicken	mosquito
(2)	mango tree	fern
(3)	beetle	butterfly
(4)	cockroach	frog

10. Which one of the following shows the life cycle of a mango tree?

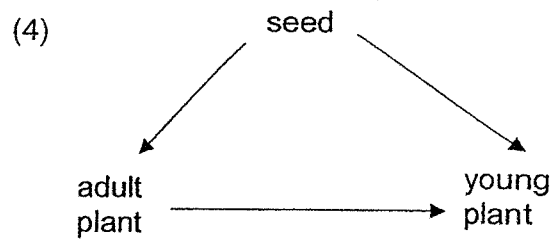
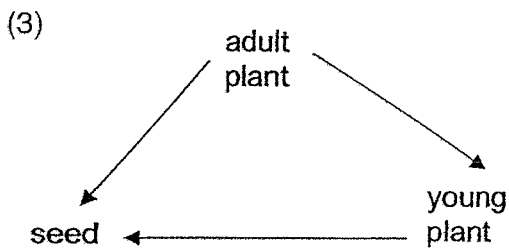
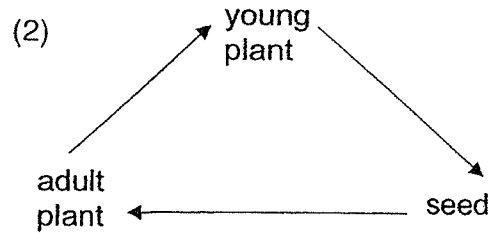
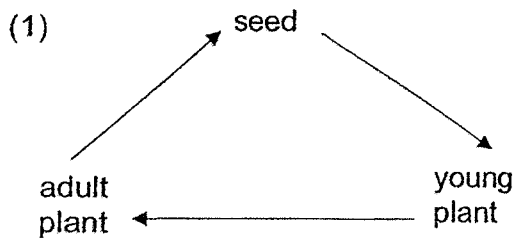

11. Study the table below.

Break easily	Absorb water	Flexible
ceramic pot glass vase ceramic bowl	cotton cloth woollen jacket rubber gloves	cotton shirt paper bag wooden ruler

Which of the object(s) above is/are classified **wrongly**?

- (1) cotton shirt only
- (2) glass vase only
- (3) woollen jacket and paper bag only
- (4) rubber gloves and wooden ruler only

Study the diagram below and answer Questions 12 and 13.

The diagram below shows a mobile phone.

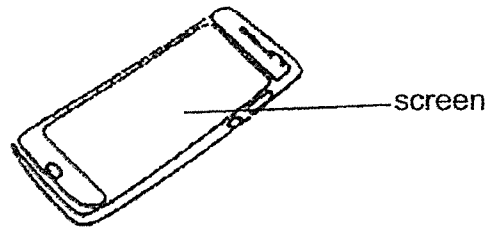

12. Which one of the following materials is most suitable for making the screen?

- (1) wood
- (2) metal
- (3) fabric
- (4) glass

13. Which property of material is needed so that the user can see the display on the screen?

- (1) It is flexible.
- (2) It can float on water.
- (3) It does not absorb water.
- (4) It allows most light to pass through.

14. Study the diagram below.

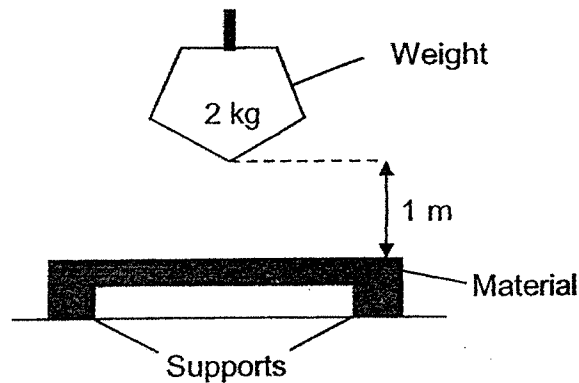

Daryl wanted to find out how many times materials Q, R, S and T can be hit before it breaks. He dropped a 2 kg-weight from a height of 1 metre onto material Q. He then repeated the experiment on materials R, S and T.

The table below shows the number of times the weight was dropped before the material breaks.

Material	Number of hits
Q	37
R	51
S	68
T	51

Based on the results, which one of the following statements is correct?

- (1) R is stronger than T.
- (2) T is stronger than Q.
- (3) Q is less flexible than S.
- (4) S is less flexible than R.

15. Study the diagram below.

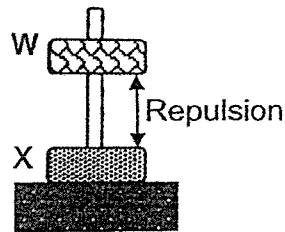

Jane observed the behaviour of 2 objects, W and X, and made the following statements:

- A object W and object X are both magnets.
- B object W is a magnet while object X is a non-magnetic metal.
- C object W and object X have their unlike poles facing each other.

Which of the above statements about objects W and X are correct?

- (1) A only
- (2) B only
- (3) A and C only
- (4) B and C only

16. The diagram below shows what happens when a magnet was brought near some steel paper clips.

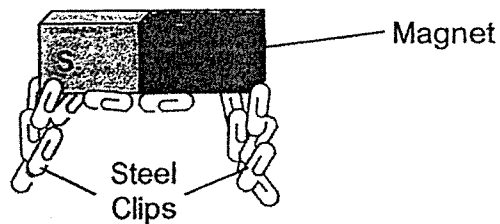

Which property of magnets does the above diagram show?

- (1) The centre of a magnet has no magnetic pull.
- (2) The poles of a magnet have the strongest magnetic pull.
- (3) When like poles of magnets are facing each other, they repel.
- (4) A magnet always comes to a rest in the North-South direction.

17. Hui Jun has a bar magnet. She dropped it accidentally and it broke into two smaller pieces as shown in the diagram below.



Which one of the following shows the poles of the broken magnets?

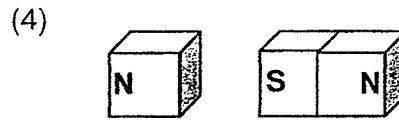
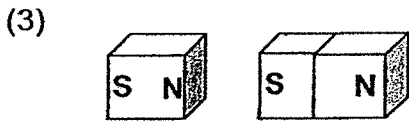
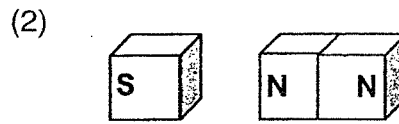
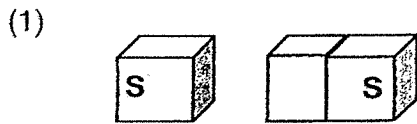

18. The needle of a compass is a magnet.

Which one of the following shows the position of a freely-suspended magnet?

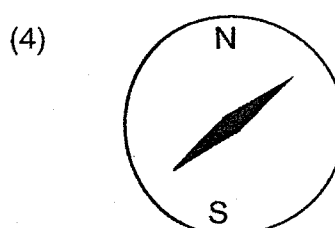
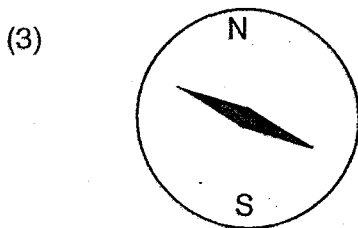
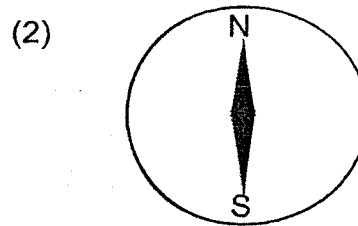
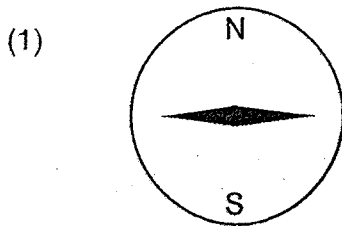

19. The examples below use the property of magnets to work.

Like poles of magnets facing each other will repel.

Which one of the following uses the above property of magnets to work?

(1)

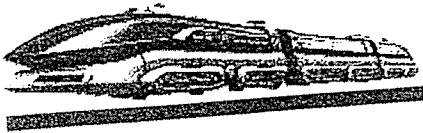

Maglev train floating above track

(2)

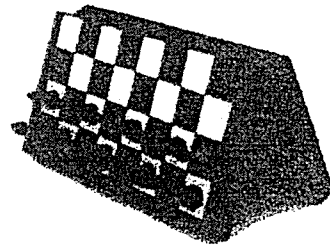

chess pieces on a chess board

(3)



closing door of the fridge tightly

(4)



door stopper keeping door open

20. Jennifer wanted to make a temporary magnet by using the stroke method. She has a horseshoe magnet. The arrows in the diagrams below show the direction of the stroking.

Which one of the following shows how she could make a temporary magnet?

(1)

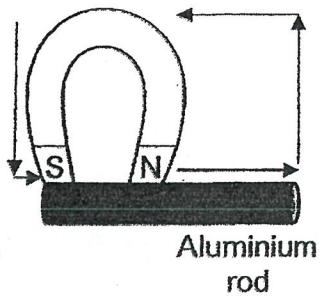

(2)

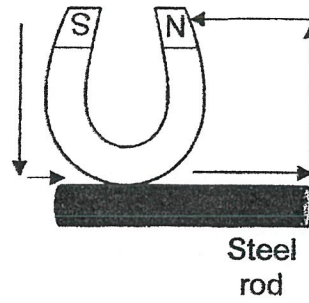

(3)

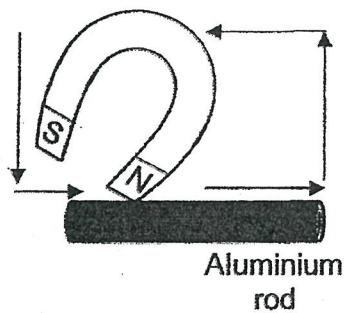

(4)

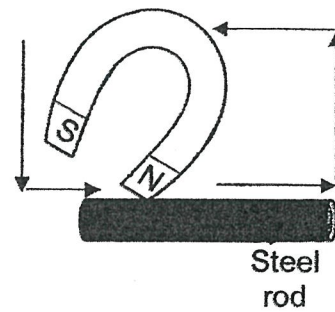

21. Study the diagram below.

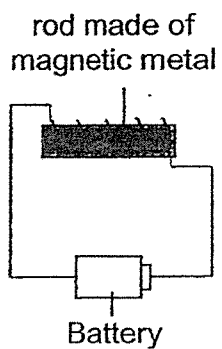

In which one of the following setups will the rod attract the most number of steel paper clips?

(1)

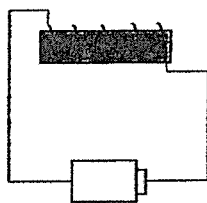

(2)

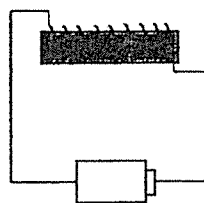

(3)

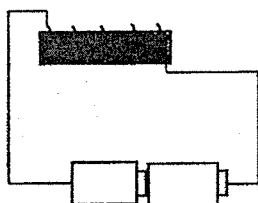

(4)

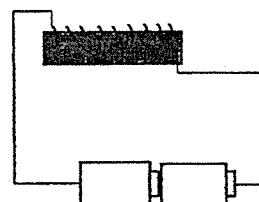

22. The diagram below shows an electromagnet.

The electromagnet is used in a junkyard to sort materials.

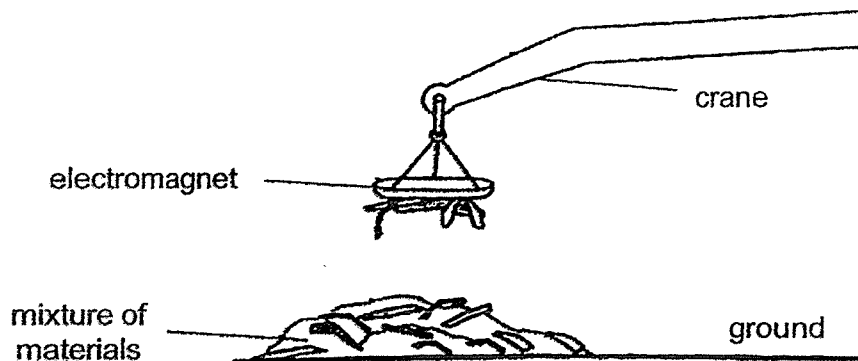

Study the statements below.

- A The electromagnet cannot work from a distance.
- B The electromagnet can be used to remove waste made of iron and steel.
- C The electromagnet will still be able to work even after electricity has been switched off.

Which of the statement(s) above is/are correct?

- | | |
|------------------|------------------|
| (1) B only | (2) C only |
| (3) A and B only | (4) A and C only |

~ END OF BOOKLET A ~



NANYANG PRIMARY SCHOOL

**2022
PRIMARY 3
END-OF-YEAR EXAMINATION**

**SCIENCE
(BOOKLET B)**

Total Time for Booklets A and B: 1 h 30 min

INSTRUCTIONS TO CANDIDATES

1. Write your name and index number in the space provided.
2. Do not open this booklet until you are told to do so.
3. Follow all instructions carefully.
4. Answer all questions.
5. Write your answers to Questions 23 to 31 in the spaces provided.

Booklet A:		44
Booklet B:		26
Total:		70

Name: _____ ()

Class: Primary 3 ()

Parent's signature: _____

Please sign and return the paper the next day. Any queries should be raised at the same time when returning the paper.

Booklet B consists of 9 printed pages excluding this cover page.

Section B: Open-Ended Questions [26 marks]

23. The table below shows the characteristics of W, X, Y and Z.

Things	Needs air, water and food to stay alive	Needs sunlight to make food	Can respond to changes around it
W	✓		✓
X			
Y			✓
Z	✓	✓	✓

Based on the information given in the table above, put a tick (✓) in the correct box to indicate if the statements are "True", "False" or "Not possible to tell". [2]

(a)	W is an animal.	True <input type="checkbox"/>	False <input type="checkbox"/>	Not possible to tell <input type="checkbox"/>
(b)	X is the only non-living thing.	True <input type="checkbox"/>	False <input type="checkbox"/>	Not possible to tell <input type="checkbox"/>
(c)	W, Y and Z are living things.	True <input type="checkbox"/>	False <input type="checkbox"/>	Not possible to tell <input type="checkbox"/>
(d)	Z is a plant.	True <input type="checkbox"/>	False <input type="checkbox"/>	Not possible to tell <input type="checkbox"/>

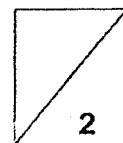

24. The classification diagram below shows how some plants can be classified.

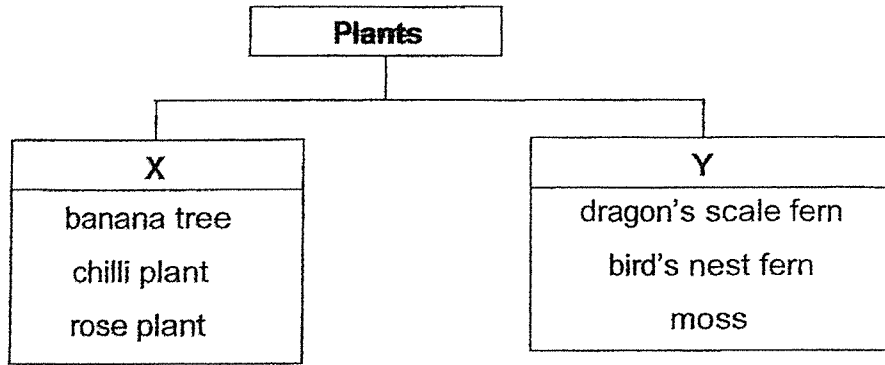

(a) Give a suitable heading for X and Y. [1]

(i) X: _____

(ii) Y: _____

(b) Other than the characteristics given in (a), state **another** difference in characteristics between the plants in group X and group Y. [1]

25. Study the diagrams below.

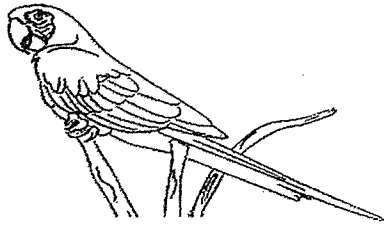

parrot

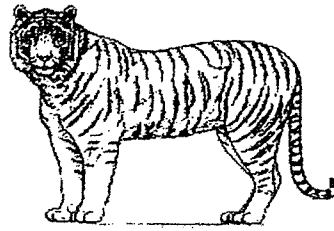

tiger

(a) State one similar function of the outer body coverings for both animals. [1]

(b) Other than the outer body coverings, state another difference in characteristics between the parrot and the tiger shown in the diagrams above. [1]

26. The diagram below shows a slice of bread with mould growing on it.

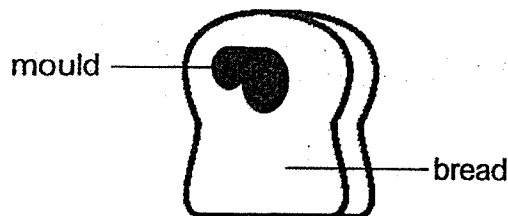

(a) Where does the mould obtain its food from? [1]

(b) Suggest one way to increase the amount of mould growing on the bread. [1]

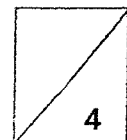

27. Study the flowchart below.

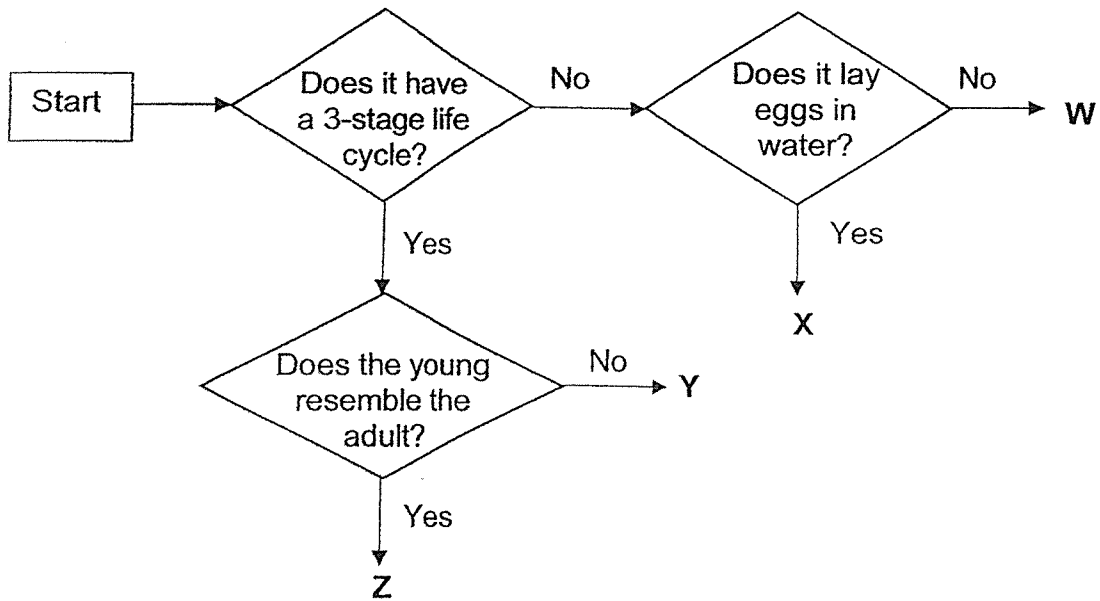

(a) Give an example of animals X and Z. [2]

X: _____

Z: _____

(b) Based only on the flowchart above, state all the characteristics of animal Y. [1]

(c) Based on the flowchart above, state a similarity between animal Y and animal Z. [1]

(d) Give a reason why the young of animal W and animal X moult several times during the larva stage. [1]

28. The diagram below shows the stages of the life cycle of a tomato plant.

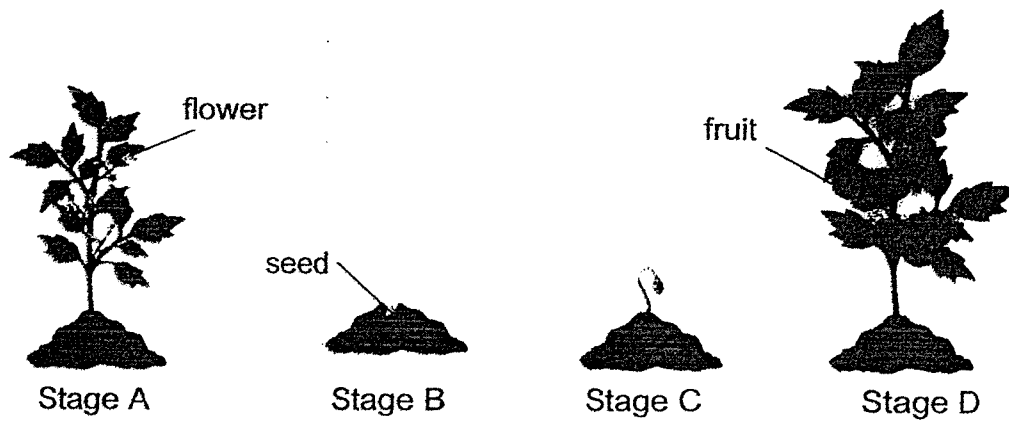

(a) Using the stages above, write A, B, C and D in the diagram below to show the order of the tomato plant's life cycle. [1]

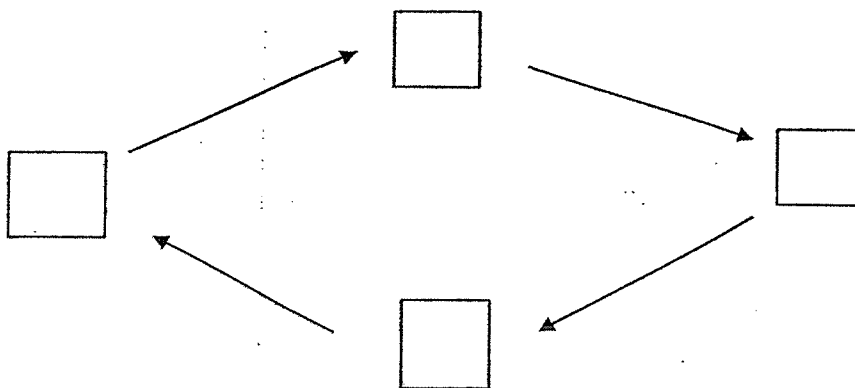

(b) When a seed germinates, it will get its food from the seed leaves.

Besides food, state the other 3 conditions that the seed needs to have in order to germinate. [2]

29. Uncle Lennon needed to make a pair of rain boots as shown in the diagram below.



The table below shows the properties of materials W, X, Y and Z.

Property	Material W	Material X	Material Y	Material Z
Is it strong?	No	No	Yes	Yes
Does it absorb water?	Yes	No	Yes	No

(a) Using information from the table above, which material, W, X, Y or Z, is the most suitable for making the rain boots? [1]

Material _____

(b) Using one of the properties in the table above, give a reason why the material you have chosen in (a) is the most suitable. [2]

30. Objects D, E, F and G are hung side by side on a pole as shown in the diagram below.

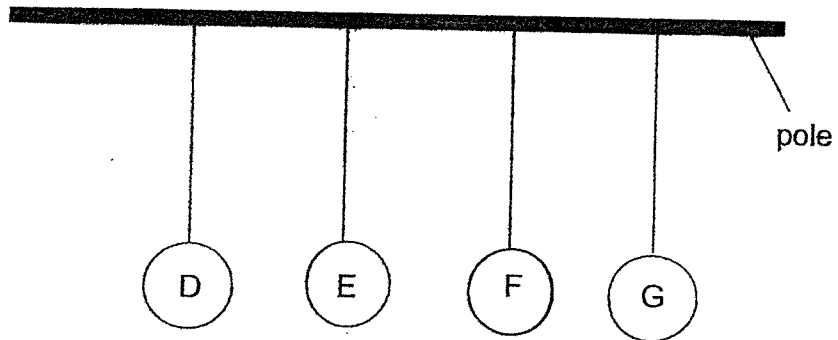

Nick squeezed objects D, E, F and G together before letting them go. He observed that the object remained in the position as shown below after Nick released them.

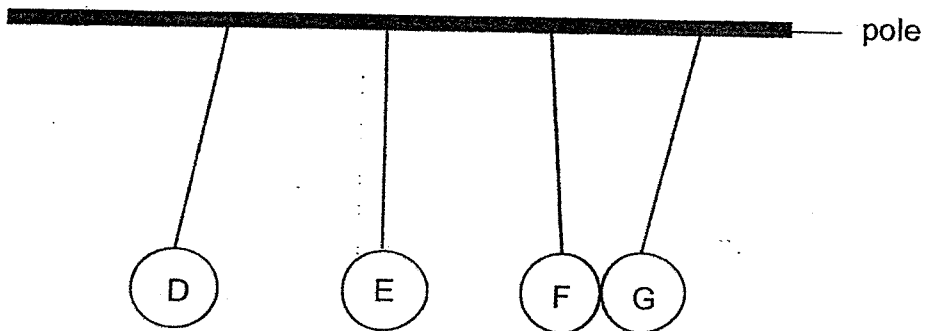

(a) Give an example of object G. [1]

(b) Explain why object D and E moved away from each other. [2]

31. Study the diagram below.

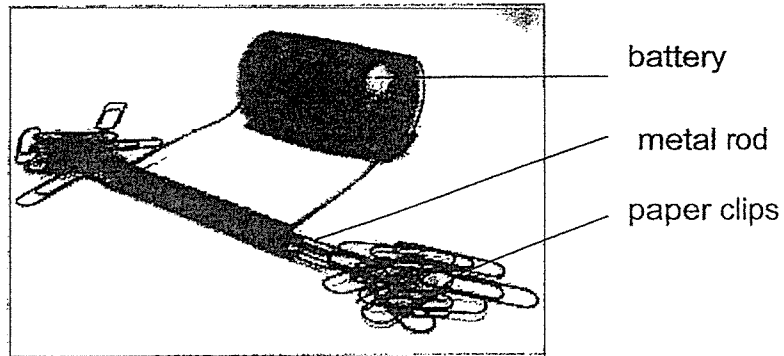

Tiffany coiled a wire around a metal rod and connected a battery to wire. She saw some paper clips were “stuck” to the ends of the metal rod.

- (a) Suggest a type of metal that the paper clips could be made of. [1]

- (b) Explain your answer in (a). [1]

- (c) Suggest two changes to make to the above so that the metal rod can attract more paper clips to the metal rod. [2]

i. _____

ii. _____

~ END OF BOOKLET B ~

Nanyang Primary School
P3 SCIENCE EYE 2022
Answer Key

Section A

1	3	6	2	11	4	16	2	21	4
2	2	7	3	12	4	17	3	22	1
3	3	8	2	13	4	18	2		
4	1	9	1	14	2	19	1		
5	3	10	1	15	1	20	4		

Section B

Q23	NPTT / F / F / T
Q24(a)	X: Flowering plant Y: Non-flowering plant
(b)	Plants in group X reproduce by seeds but the plants in group Y reproduce by spores.
Q25(a)	Both body coverings keep the animals warm.
(b)	Parrot has wings but the tiger does not have wings.
Q26(a)	It obtains food from the bread.
(b)	Add a few drops of water to the bread.
27. (a)	X : mosquito Z : cockroach
(b)	Y has 3-stage life cycle and its young does not resemble its adult.
(c)	Both have 3-stage life cycles.
(d)	The young of W and X moult to grow bigger.
28. (a)	B, C, A, D
(b)	Water, air (oxygen), warmth (right temperature)

Q29(a)	Material Z
(b)	It is waterproof so that the person's feet will not get wet on a rainy day.
Q30(a)	Magnet / steel ball
(b)	Objects D and E repel each other. They are magnets with like poles facing each other.
Q31(a)	Steel / Iron / Cobalt / Nickel
(b)	Iron is a magnetic material so the electromagnet can attract the paper clips
(c)	i. Increase the number of coils of wire around the metal rod. ii. Increase the number of batteries used.