

**CATHOLIC HIGH SCHOOL**  
**END-OF-YEAR EXAMINATION (2022)**  
**PRIMARY THREE**  
**SCIENCE**  
**BOOKLET A**

Name: \_\_\_\_\_ ( )

Class: Primary 3 - \_\_\_\_\_

Date: 28 October 2022

24 questions

48 marks

Total Time for Booklets A and B: 1 hour 30 minutes

**INSTRUCTIONS TO CANDIDATES**

Do not turn over this page until you are told to do so.

Follow all instructions carefully.

Answer all questions.

Shade your answers in the Optical Answer Sheet (OAS) provided.

This booklet consists of 14 printed pages, excluding the cover page.



**Booklet A (24 × 2 marks)**

For each question from 1 to 24, four options are given. One of them is the correct answer. Make your choice (1, 2, 3 or 4). Shade your answer on the Optical Answer Sheet. (48 marks)

1 Study the diagram.

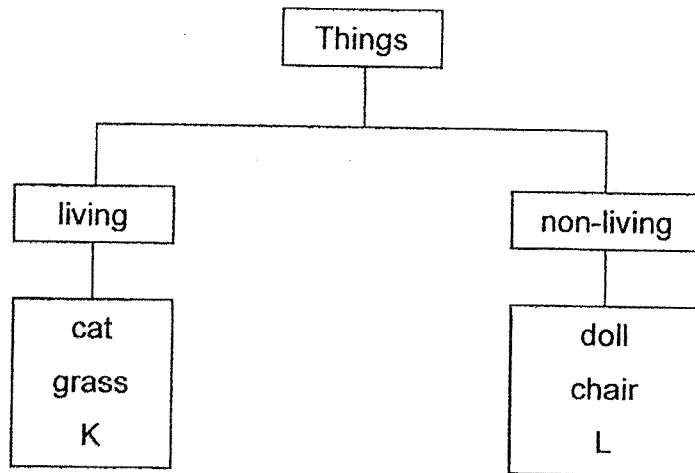

Which of the following best represents K and L?

|     | K         | L     |
|-----|-----------|-------|
| (1) | bird      | nail  |
| (2) | balloon   | table |
| (3) | butterfly | fish  |
| (4) | aeroplane | tree  |

- 2 The table shows the characteristics of three things, A, B and C. A tick (✓) in the box shows the characteristic the thing has.

| Thing | Can make its own food | Needs air to survive | Responds when touched |
|-------|-----------------------|----------------------|-----------------------|
| A     |                       | ✓                    | ✓                     |
| B     |                       |                      | ✓                     |
| C     | ✓                     | ✓                    | ✓                     |

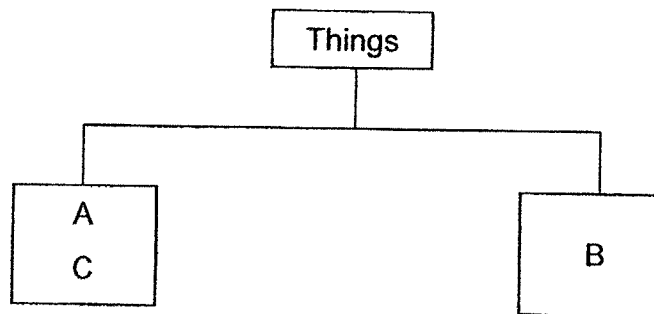

Which of the following is correct?

|     | A     | B     | C     |
|-----|-------|-------|-------|
| (1) | toy   | ant   | plant |
| (2) | ant   | plant | toy   |
| (3) | ant   | toy   | plant |
| (4) | plant | ant   | toy   |

- 3 Three children made the following statements about ferns.

Ann Ferns reproduce from spores.

Bob Ferns are not plants as they do not reproduce from seeds.

Cain Ferns obtain their food from the living or non-living things that they grow on.

Who made the correct statement(s)?

Ann only

Bob only

Ann and Cain only

Bob and Cain only

- 4 The table shows the characteristics of two plants, X and Y. A tick (✓) in the box shows the characteristic the plant has.

| Characteristics          | Plant X | Plant Y |
|--------------------------|---------|---------|
| bears flowers and fruits | ✓       | ✓       |
| grows on land            |         | ✓       |

Based on the information above, which diagram shows the correct classification of plants X and Y?

(1)

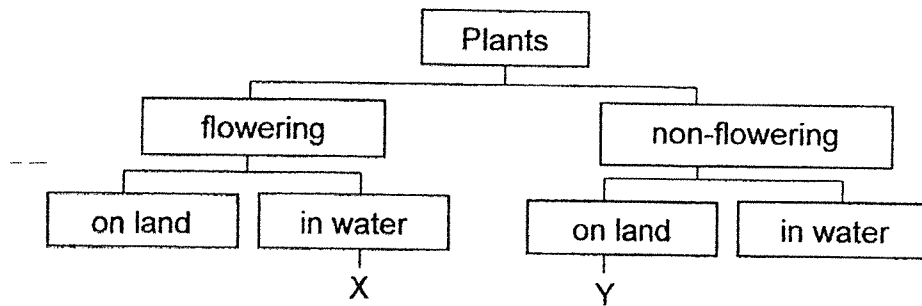

(2)

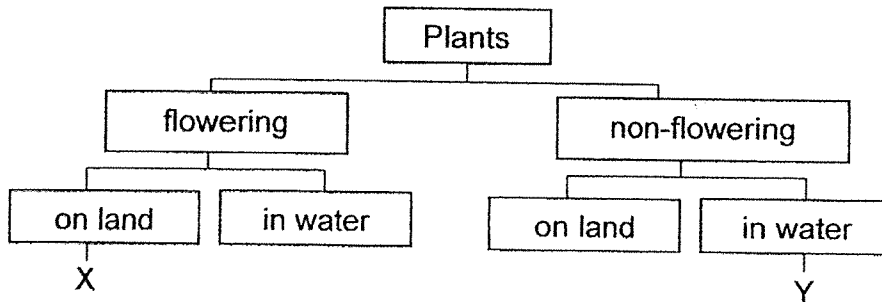

(3)

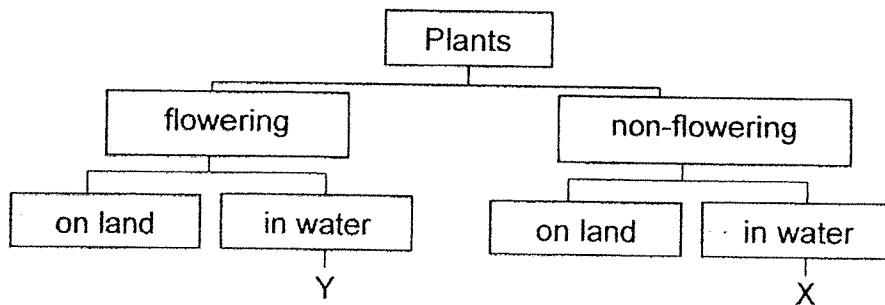

(4)

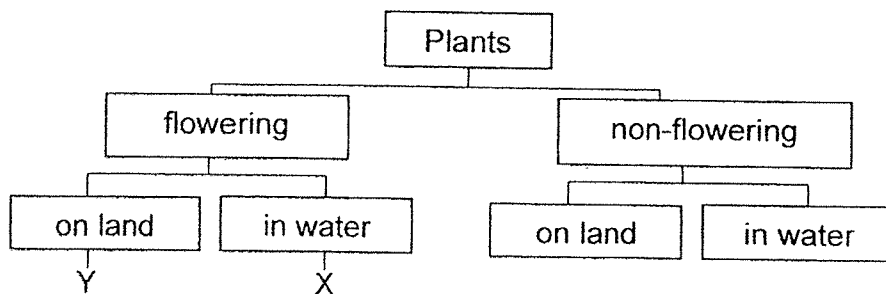

5 Study the animals, A, B, C and D.



Which animal is an insect?

- (1) A
- (2) B
- (3) C
- (4) D

6 The diagram shows the characteristics of four groups of animals.

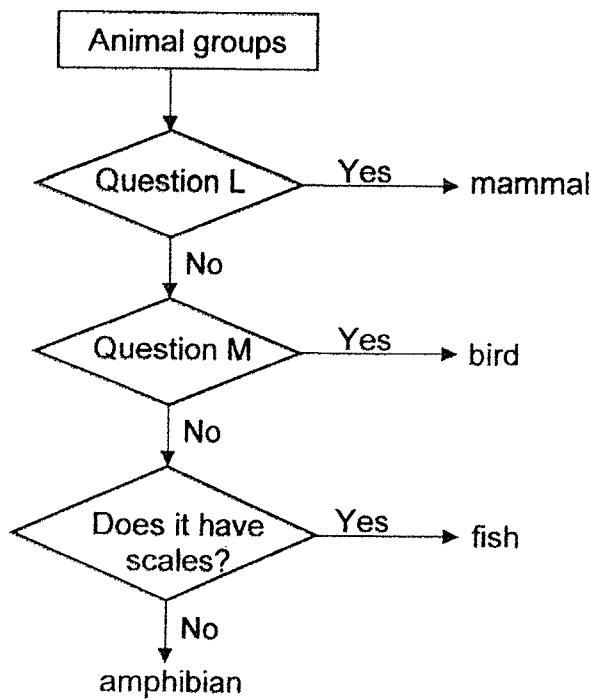

Which of the following represents questions L and M?

|     | L                   | M                      |
|-----|---------------------|------------------------|
| (1) | Does it grow?       | Does it reproduce?     |
| (2) | Does it have hair?  | Does it have feathers? |
| (3) | Does it have wings? | Does it lay eggs?      |
| (4) | Does it have lungs? | Does it have legs?     |

7 Which statements about bacteria is/are correct?

- A Bacteria can reproduce.
- B Bacteria are microorganisms.
- C Bacteria cannot grow in water.
- D Bacteria in our bodies are harmful.

- (1) A only
- (2) A and B only
- (3) C and D only
- (4) B, C and D only

8 Ali had three similar cups of milk placed in different places for two days.

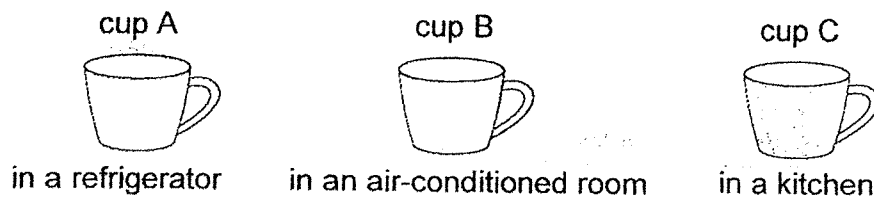

The amount of bacteria in each cup was recorded as shown.

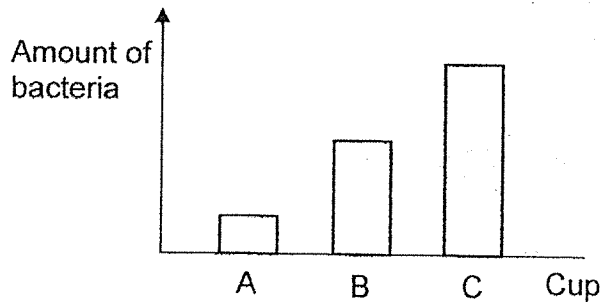

Based on the results, what can Ali conclude about the bacteria?

Bacteria grow well \_\_\_\_\_.

- (1) in milk
- (2) without air
- (3) in warm places
- (4) without sunlight

- 9 Meiling had two balls, A and B, made of different materials. She dropped both balls into a basin of water.

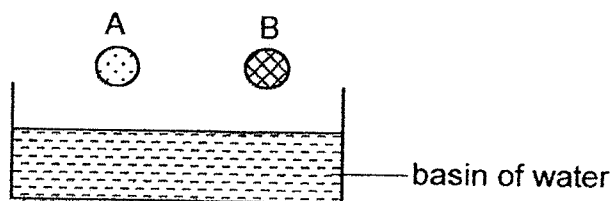

Which property of the material was Meiling testing?

- (1) strength
  - (2) flexibility
  - (3) ability to float or sink
  - (4) ability to allow light to pass through
- (3)

- 10 Rani wanted to find out the strength of four strings, M, N, P and Q, made of different materials. She tied a pan at the end of string M.

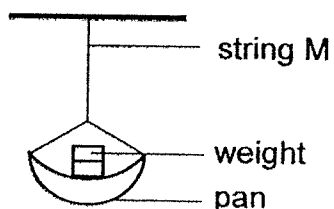

She placed some weights, one at a time, onto the pan until string M broke. She repeated the experiment with strings, N, P and Q, and recorded the results in the table.

| String | Number of weights the string could hold until it broke |
|--------|--|
| M      | 4  |
| N      | 10   |
| P      | 6  |
| Q      | 12   |

Based on the results, which statement is correct?

- (1) String P is stronger than string M.
- (2) String N is stronger than string Q.
- (3) String P is stronger than string N.
- (4) String M is stronger than string Q.

- 11 Fishmongers normally wear boots when they are working in wet markets.



Why is rubber usually used to make these boots?

- A It can float.
- B It is flexible.
- C It is waterproof.
- D It allows light to pass through.

- (1) A and C only
- (2) A and D only
- (3) B and C only
- (4) A, B, C and D

- 12 Four children made the following statements about what a system is.

- Ali All systems are man-made.
- Ben A system is made up of several parts.
- Carl A ruler is a system as it can measure length.
- Dan A system cannot carry out its function well if one of its parts is missing.

Who made the correct statements?

- (1) Ali and Ben
- (2) Ali and Carl
- (3) Ben and Dan
- (4) Carl and Dan

13 Which body parts are **not** correctly matched to the body system?

|   | Body part | Body system        |
|---|-----------|--------------------|
| A | ribs      | muscular system    |
| B | heart     | circulatory system |
| C | gullet    | skeletal system    |
| D | windpipe  | digestive system   |
| E | backbone  | skeletal system    |

- (1) A and D only
- (2) B and E only
- (3) A, C and D only
- (4) B, C and E only

14 Which statement about the human digestive system is **not** correct?

- (1) Solid waste is passed out from the anus.
- (2) The large intestine absorbs water from the digested food.
- (3) Some digestive juices are added to the food in the stomach.
- (4) Digested food is absorbed into the blood in the small intestine.

15 Ken ran in a 100 m race.

Which body system(s) did he use when he was running?

- A skeletal system
- B muscular system
- C circulatory system
- D respiratory system

- (1) D only
- (2) A and D only
- (3) B and C only
- (4) A, B, C and D

16 Study the diagram.

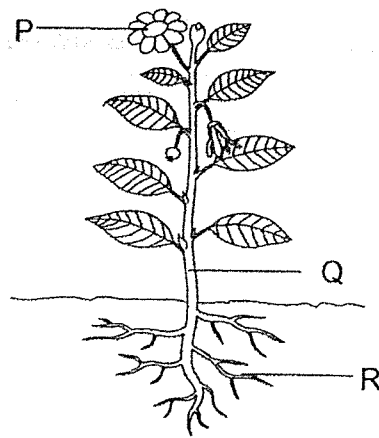

Which of the following correctly represents parts, P, Q and R?

|     | P      | Q    | R    |
|-----|--------|------|------|
| (1) | fruit  | stem | root |
| (2) | fruit  | leaf | stem |
| (3) | flower | leaf | stem |
| (4) | flower | stem | root |

17 Study the diagram.

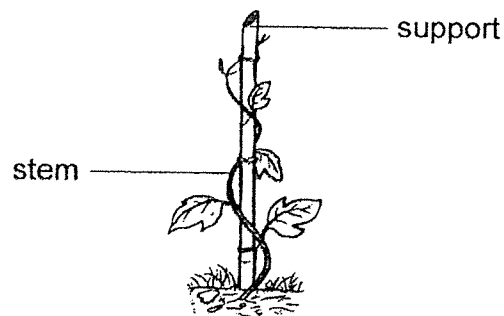

The plant climbs up a support to get \_\_\_\_\_.

- (1) air
- (2) food
- (3) water
- (4) sunlight

18 Rahim wanted to find out if plants take in water through the roots.

Which variable should Rahim change in his experiment?

- (1) amount of water
- (2) presence of roots
- (3) amount of sunlight
- (4) presence of leaves

19 Susan was given some magnets. She arranged them into four different set-ups, W, X, Y and Z.

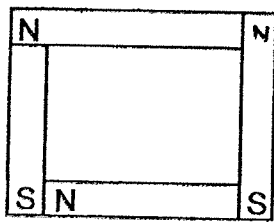

W

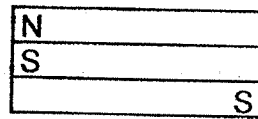

X

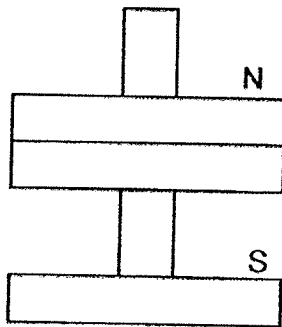

Y

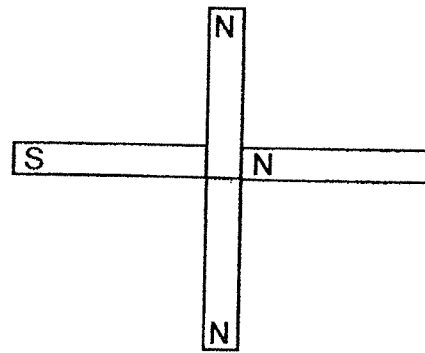

Z

Which arrangement(s) is/are **not** possible?

- (1) W only
- (2) X and Y only
- (3) W and Z only
- (4) W, Y and Z only

- 20 Rosa conducted an experiment using two similar magnets. She counted the number of pins attracted to each magnet.

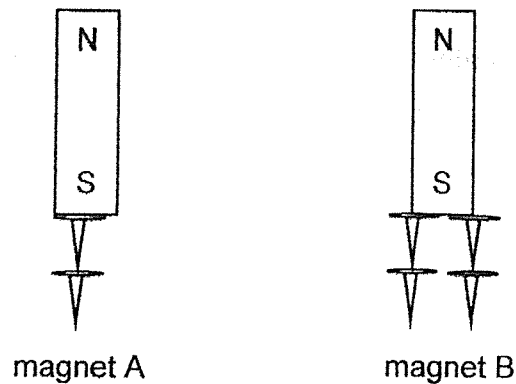

She wanted to find out if \_\_\_\_\_.

- (1) magnet A attracts the pins
  - (2) the pins are made of steel
  - (3) a magnet is strongest at its poles
  - (4) magnet B is stronger than magnet A
- 21 Indra placed a magnet near three objects, J, K and L. He observed what happened to the three objects and recorded his observations.

| Object | Attract | Repel |
|--------|---------|-------|
| J      | yes     | no    |
| K      | no      | no    |
| L      | yes     | yes   |

Based on Indra's observation, what could J, K and L be?

|     | J          | K          | L          |
|-----|------------|------------|------------|
| (1) | iron bar   | copper bar | bar magnet |
| (2) | copper bar | iron bar   | bar magnet |
| (3) | iron bar   | bar magnet | copper bar |
| (4) | bar magnet | copper bar | iron bar   |

22 Tania placed a magnet above a bowl of pins.

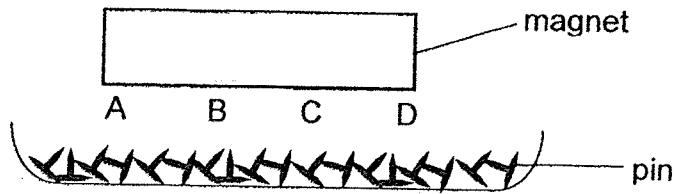

She recorded the number of pins attracted to parts, A, B, C and D, of the magnet and recorded it in the table below.

| Try             | Number of pins attracted |   |   |   |
|-----------------|--------------------------|---|---|---|
|                 | A                        | B | C | D |
| 1 <sup>st</sup> | 4                        | 2 | 3 | 6 |
| 2 <sup>nd</sup> | 2                        | 4 | 7 | 3 |
| 3 <sup>rd</sup> | 7                        | 3 | 2 | 5 |
| 4 <sup>th</sup> | 9                        | 4 | 3 | 8 |

Her teacher said that one set of results was not right.

Which set of results was **not** correct?

- (1) 1<sup>st</sup>
- (2) 2<sup>nd</sup>
- (3) 3<sup>rd</sup>
- (4) 4<sup>th</sup>

- 23 Salleh had four nails. He stroked each nail a different number of times with a magnet and recorded the results.

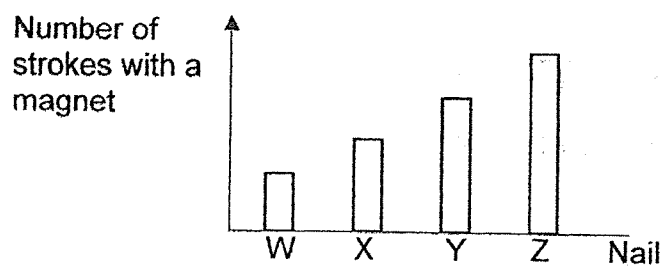

Each nail was brought near some pins.

Which nail would be able to pick up the greatest number of pins?

- (1) W
- (2) X
- (3) Y
- (4) Z

- 24 Arif wanted to find out if the number of batteries would affect the strength of an electromagnet made from a rod.

Which set-up should he use for the experiment?

(1)

| Variable            | Kept constant | Changed |
|---------------------|---------------|---------|
| type of batteries   | ✓             |         |
| number of batteries | ✓             |         |
| material of rod     |               | ✓       |
| thickness of rod    | ✓             |         |

(2)

| Variable            | Kept constant | Changed |
|---------------------|---------------|---------|
| type of batteries   | ✓             |         |
| number of batteries |               | ✓       |
| material of rod     | ✓             |         |
| thickness of rod    | ✓             |         |

(3)

| Variable            | Kept constant | Changed |
|---------------------|---------------|---------|
| type of batteries   |               | ✓       |
| number of batteries | ✓             |         |
| material of rod     |               | ✓       |
| thickness of rod    |               | ✓       |

(4)

| Variable            | Kept constant | Changed |
|---------------------|---------------|---------|
| type of batteries   |               | ✓       |
| number of batteries |               | ✓       |
| material of rod     | ✓             |         |
| thickness of rod    | ✓             |         |

End of Booklet A

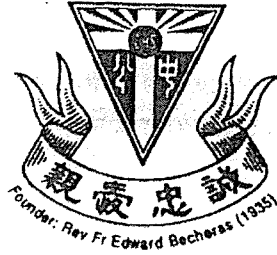

**CATHOLIC HIGH SCHOOL**  
**END-OF-YEAR EXAMINATION (2022)**  
**PRIMARY THREE**  
**SCIENCE**  
**BOOKLET B**

Name: \_\_\_\_\_ ( )

Class: Primary 3 - \_\_\_\_\_

Date: 28 October 2022

Parent's Signature: \_\_\_\_\_

|           |    |
|-----------|----|
| Booklet A | 48 |
| Booklet B | 32 |
| Total     | 80 |

10 questions

32 marks

Total Time for Booklets A and B: 1 hour 30 minutes

**INSTRUCTIONS TO CANDIDATES**

Do not turn over this page until you are told to do so.

Follow all instructions carefully.

Answer all questions.

Write your answers in this booklet.

This booklet consists of 13 printed pages, excluding the cover page.

**Booklet B (32 marks)**

For questions 25 to 34, write your answers in this booklet.

The number of marks available is shown in brackets [ ] at the end of each question or part question. (32 marks)

---

25 Study the things.



A



B

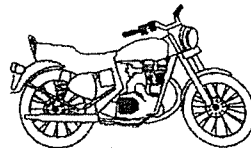

C



D

(a) State one similar characteristic between A and D.

[1]

---

(b) Classify, A, B, C and D, in the diagram. Write the letters, A, B, C and D, once only in the correct boxes. Not all the boxes need to be filled. [2]

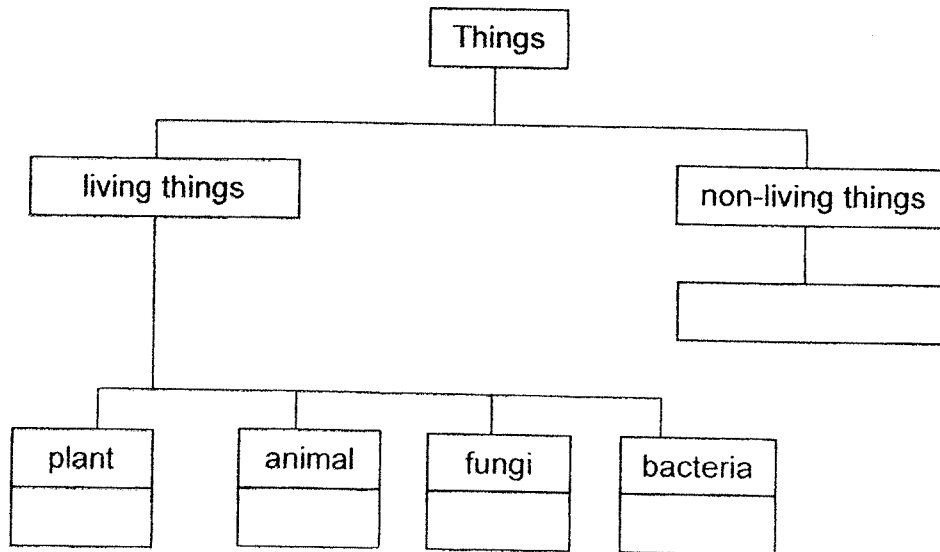

(Go on to the next page)

|       |   |
|-------|---|
| SCORE | 3 |
|-------|---|

26 The diagram shows how some fruits, P, Q, R and S, are grouped.

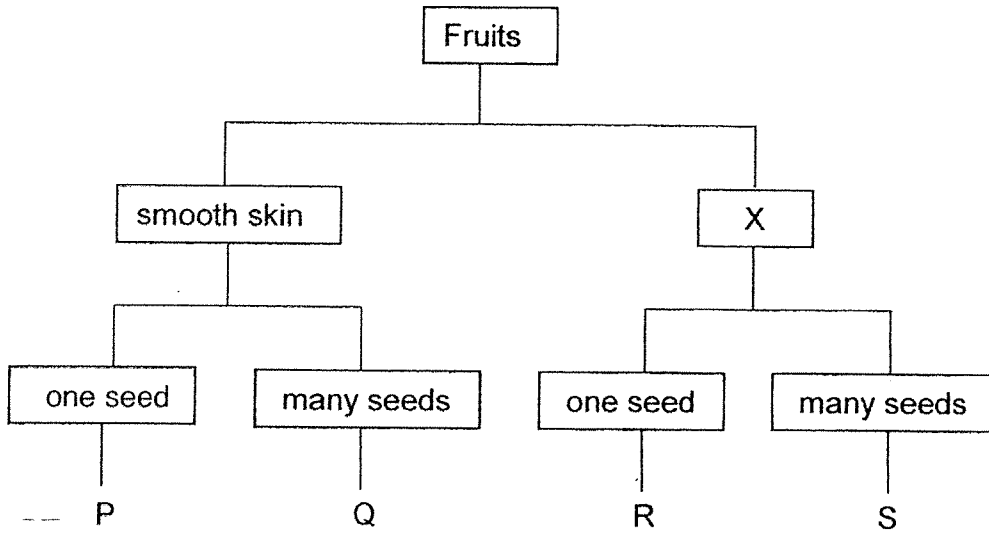

(a) Give a suitable heading for X. [1]

---

(b) Based on the diagram, state the characteristics of fruit Q. [1]

---

---

(c) Based on the diagram, state one similarity between fruit Q and fruit S. [1]

---

(Go on to the next page)

|       |   |
|-------|---|
| SCORE | 3 |
|-------|---|



27 Ming went to the zoo and saw four animals. He grouped them according to a common characteristic.



eagle

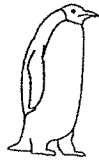

penguin



bat



pigeon

(a) Based on the diagrams, what was the common characteristic used to group the animals? [1]

\_\_\_\_\_

The four animals are then regrouped into Groups J and K.

| Group J | Group K                    |
|---------|----------------------------|
| bat     | eagle<br>penguin<br>pigeon |

(b) Give suitable headings for Groups J and K. [1]

Group J : \_\_\_\_\_

Group K: \_\_\_\_\_

Ming then saw a dolphin.



(c) Ming classified the dolphin in Group J. Do you agree? Give a reason. [1]

\_\_\_\_\_

(Go on to the next page)

|       |   |
|-------|---|
| SCORE | 3 |
|-------|---|

28. Aini placed two similar buns in set-ups, W and X, in the kitchen.

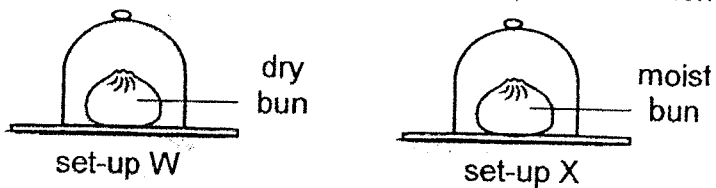

After one week, she observed patches of mould growing on the bun in set-up X.

(a) Based on the experiment, state the condition that caused the growth of mould.

[1]

---

Aini had two cupboards, Y and Z, to put her shoes. She placed a tub of moisture absorber in cupboard Y to remove the moisture inside it.



Six months later, Aini observed white patches of mould on a pair of shoes.

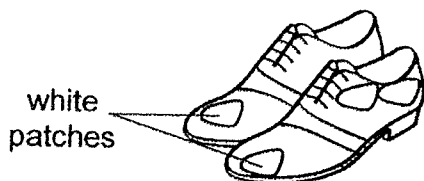

(b) In which cupboard, Y or Z, was this pair of shoes placed? Explain.

[2]

---

---

---

(Go on to the next page)

|       |   |
|-------|---|
| SCORE | 3 |
|-------|---|



Continue from Question 29

- (b) Put a tick (✓) in the box(es) below to indicate the changed variable based on John's experiment. [1]

| Variable                   | Changed |
|----------------------------|---------|
| type of material           |         |
| number of weights used     |         |
| distance the material bent |         |

- (c) Based on John's experiment, which material, X, Y or Z, is the most suitable for making a food tray? Give a reason. [2]



---

---

---

(Go on to the next page)

|       |   |
|-------|---|
| SCORE | 3 |
|-------|---|

30 Study the set-up.

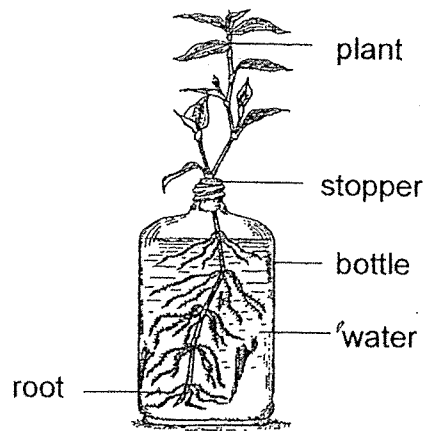

The amount of water in the bottle was observed at the end of five days.

- (a) Would the amount of water in the bottle increase, decrease or remain the same after five days? [1]

---

- (b) Give a reason for your answer in (a). [1]

---

During a thunderstorm, the roots of a tree were pulled out of the ground.



- (c) Based on the diagram, state another function of the roots. [1]

---

---

(Go on to the next page)

|       |   |
|-------|---|
| SCORE | 3 |
|-------|---|

31 Zann grouped the various human body systems.

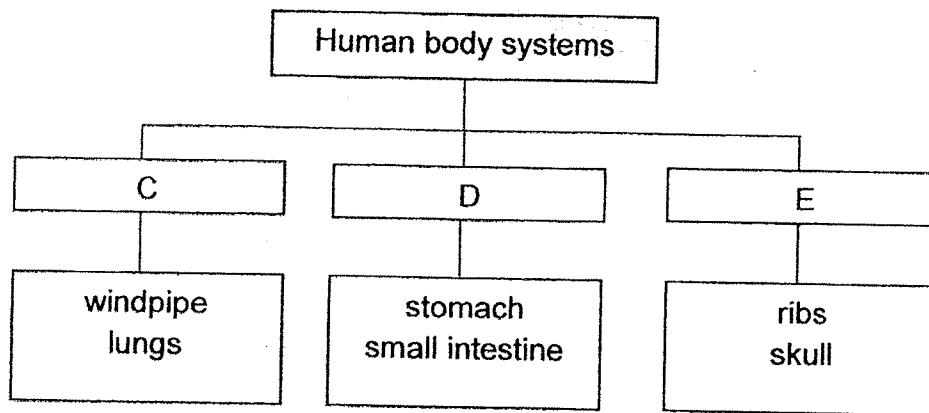

(a) What are systems C and D? [1]

C: \_\_\_\_\_

D: \_\_\_\_\_

(b) What is the function of system E? [1]

\_\_\_\_\_  
\_\_\_\_\_

(Go on to the next page)

|       |   |
|-------|---|
| SCORE | / |
|       | 2 |

32 Lily made a toy with a rod and a magnet. Then she moved the rod over several objects.

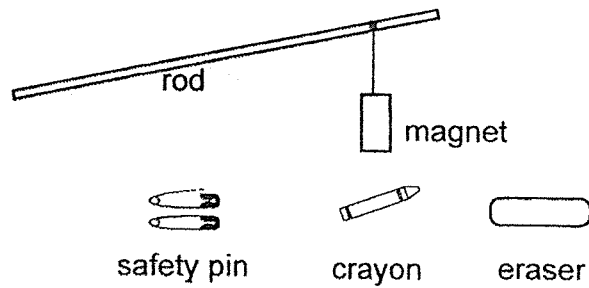

(a) Lily observed what would happen to the objects when the magnet was brought near them.

(i) Give a suitable heading for Groups M and N in the diagram. [1]

(ii) Based on Lily's observation, classify the safety pin and the crayon. [1]

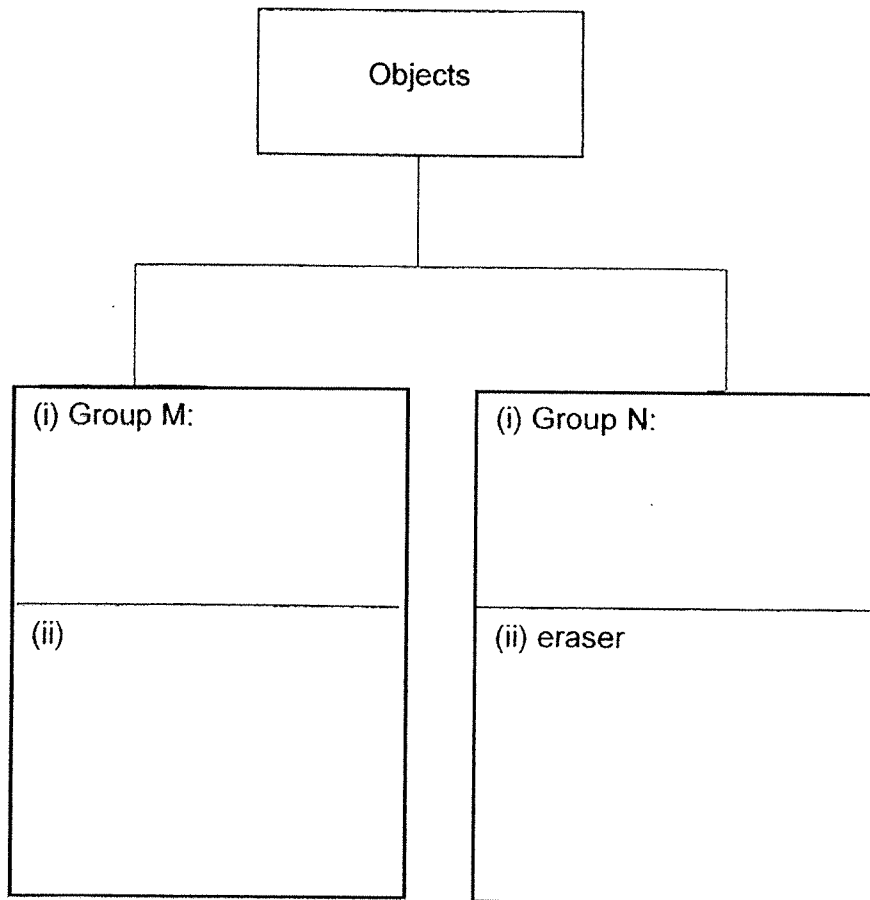

(Go on to the next page)

|       |   |
|-------|---|
| SCORE | 2 |
|-------|---|

Continue from Question 32

Lily was at a car workshop and noticed that the iron parts of some tools were being held by bar X that was fixed to the wall.

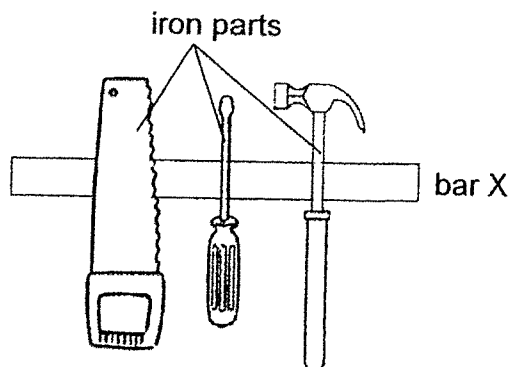

(b) What is bar X? [1]

---

(c) Explain how the iron parts of the tools were held to bar X. [1]

---

---

(Go on to the next page)

|       |   |
|-------|---|
| SCORE | 2 |
|-------|---|

- 33 Kassim attached object X to a plastic toy car. When he placed an iron rod beside the toy car, his observation was as shown.

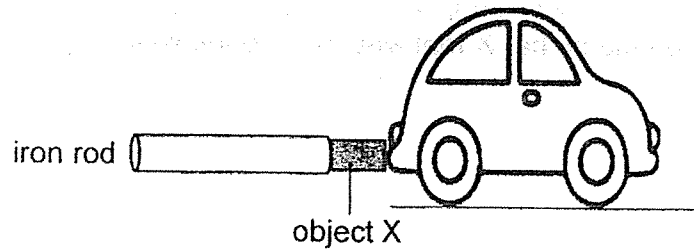

Then he coiled a wire around the iron rod and added a battery to make an electromagnet. He placed the toy car next to the electromagnet and observed that it moved forward.

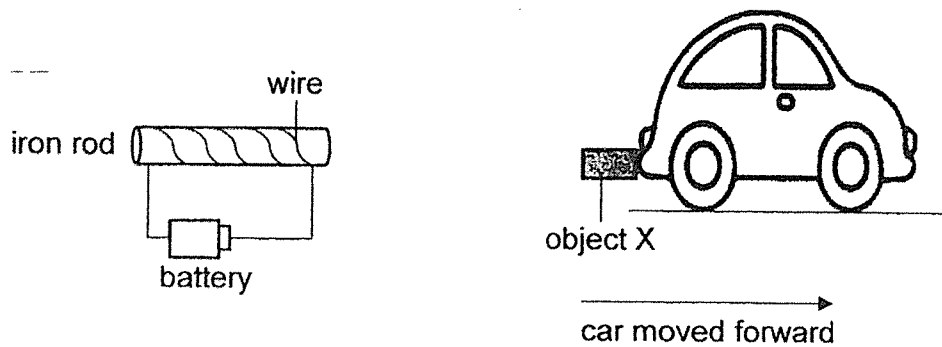

- (a) Explain what caused the car to move forward.

[1]

---

---

(Go on to the next page)

|       |   |
|-------|---|
| SCORE | 1 |
|-------|---|

Continue from Question 33

Kassim wanted his car to move faster.

- (b) Suggest two changes that he could make to the electromagnet to make his car move faster. [2]

(i) \_\_\_\_\_

(ii) \_\_\_\_\_

- (c) When Kassim used a wooden rod to make an electromagnet, he observed that the toy car did not move forward. Give a reason. [1]

\_\_\_\_\_

---

\_\_\_\_\_

(Go on to the next page)

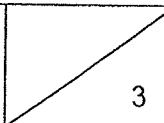
|       |   |
|-------|---|
| SCORE |  |
|-------|---|

- 34 Bala tied a string to object L. He attached a magnet at the top of the box and observed that object L was able to 'float' in the air.

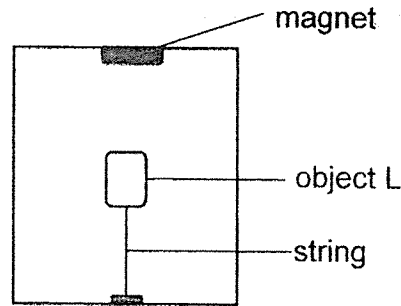

- (a) State the property of object L that allowed it to 'float' in the air. [1]

---

Bala removed the magnet and dropped it several times. When he placed the magnet back again, he noticed that object L was no longer able to 'float' in the air.

- (b) Based on Bala's observation, what had happened to the magnet after being dropped several times? [1]

---

---

Bala had a bar labelled N and a rod magnet. When bar N was brought close to the rod magnet, bar N was attracted to the rod magnet.

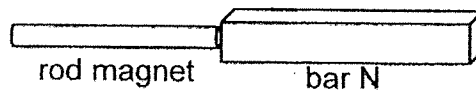

- (c) Based on this observation, can Bala conclude that bar N is a magnet? Explain why. [1]

---

---

End of Booklet B

|       |   |
|-------|---|
| SCORE | 3 |
|-------|---|



**SCHOOL: CATHOLIC HIGH SCHOOL**

**SUBJECT: SCIENCE**

**LEVEL: PRIMARY 3**

**PAPER: EOY**

**BOOKLET A**

|     |   |     |   |     |   |     |   |     |   |
|-----|---|-----|---|-----|---|-----|---|-----|---|
| Q1  | 1 | Q2  | 3 | Q3  | 1 | Q4  | 4 | Q5  | 1 |
| Q6  | 2 | Q7  | 2 | Q8  | 3 | Q9  | 3 | Q10 | 1 |
| Q11 | 3 | Q12 | 3 | Q13 | 3 | Q14 | 2 | Q15 | 4 |
| Q16 | 4 | Q17 | 4 | Q18 | 2 | Q19 | 2 | Q20 | 4 |
| Q21 | 1 | Q22 | 2 | Q23 | 4 | Q24 | 2 |     |   |

**BOOKLET B**

Q25. a) A and D can respond to changes.

b)

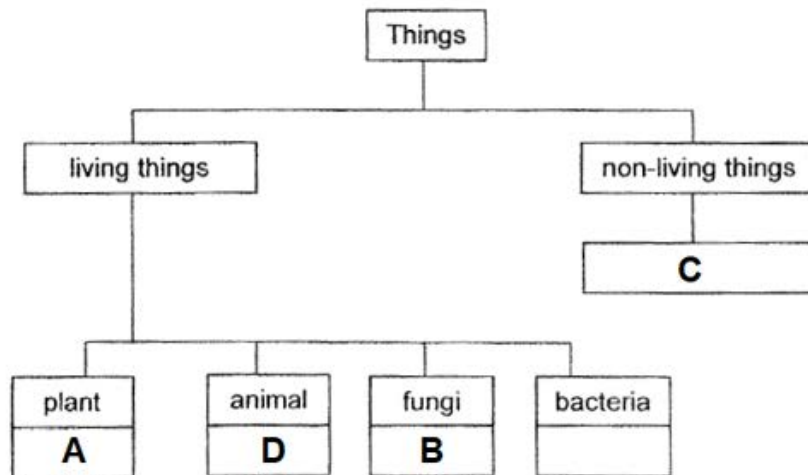

- Q26. a) Rough  
b) It has many seeds and smooth skin.  
c) They both have many seeds.

- Q27. a) Whether or not they had wings.  
b) Group J: Mammals  
Group K: Birds  
c) I agree, because dolphins are mammals.

- Q28. a) Moisture  
b) Cupboard Z. There is no moisture present for mould to grow.

- Q29. a) Y, Z, X  
b) type of material  
c) Y, because it is the least flexible.

- Q30. a) It will decrease.  
b) The roots take in water.  
c) To hold the plant firmly to the ground.

- Q31. a) C: Respiratory system  
D: Digestive system  
b) To give the body its shape and to protect the organs in the body.

**Q32. a) (i) Group M: Magnetic material**

**Group N: Non-magnetic material**

**(ii) Group M: Safety pin**

**Group N: Crayon**

**b) It is a magnet.**

**c) The iron part of the tools are a magnetic material and are attracted to bar X.**

**Q33. a) Like poles of the electromagnet and X were facing each other, hence they repel.**

**b) (i) Add more batteries**

**(ii) Increase the number of coils around the iron rod.**

**c) The wooden rod is not made of a magnetic material.**

**Q34. a) L is made of a magnetic material.**

**b) The magnet had lost its magnetism.**

**c) No. Bala must turn bar N to the other side to see if they repel each other.**

**END**