

Catholic High School (Primary)
Primary 4 Mathematics 2021
Weighted Assessment 1

NAME _____() DATE : _____

CLASS : _____

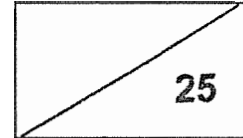

PARENT'S SIGNATURE : _____

Section A

Questions 1 to 4 carry 2 marks each. For each question, four options are given. One of them is the correct answer. Make your choice (1, 2, 3 or 4) and write your choice in the bracket provided. All diagrams are not drawn to scale. (8 marks)

1. What is the value of the digit 5 in 15 093?

(1) 5

(2) 50

(3) 500

(4) 5000

()

2. Arrange the following numbers in increasing order.

70 135, 70 315, 70 153, 70 351

(1) 70 135, 70 153, 70 351, 70 315

(2) 70 135, 70 315, 70 351, 70 153

(3) 70 135, 70 153, 70 315, 70 351

(4) 70 153, 70 135, 70 315, 70 351

()

3. There were 78 253 people in a stadium. Express this number to the nearest hundred.

(1) 78 300

(2) 78 250

(3) 78 200

(4) 78 000

()

4. Which of the following is not a factor of 81?

(1) 1

(2) 8

(3) 3

(4) 9

()

Section B

Questions 5 to 9 carry 2 marks each. Show your working clearly and write your answers in the spaces provided. For questions which require units, give your answers in the units stated. All diagrams are not drawn to scale. (10 marks)

Do not write
in this space

5. What is the missing number in the number pattern?

51 170, 51 070, 50 970, 50 870, _____, 50 670

Ans: _____

6. At a party, every 6th child gets a box of nuggets and every 8th child gets a goodie bag. Which child is the first to get both a box of nuggets and a goodie bag?

Ans: _____

7. There were 24 finalists at a gaming competition. Each of them received 20 game sets and there were 10 game sets left. How many game sets were there at first?

Do not write
in this space

Ans: _____

8. I am a number between 47 and 60. I have a remainder of 7 when I am divided by 9. What number am I?

Ans: _____

9. Mrs Yeo distributed 5350 masks equally to 5 elderly care centres without any leftovers. How many masks did each elderly care centre receive?

Ans: _____

SECTION C

For Questions 10 to 11, show your working clearly and write your answers in the spaces provided. The number of marks available is shown in brackets [] at the end of each question or part-question. All diagrams are not drawn to scale.

(7 marks)

Do not write
in this space

10. Max has less than 30 erasers. When he packs them in groups of three, he will have 1 extra eraser. When he packs them in groups of seven, he will have 5 extra erasers. How many erasers does Max have?

Ans: _____ [3]

11. Adam has three times as many stamps as Ben. Caleb has 1200 more stamps than Adam. Ben and Adam have 5780 stamps altogether. How many stamps does Caleb have?

Do not write
in this space

Ans: _____ [4]

END OF PAPER

Catholic High School (Primary)
Primary 4 Mathematics 2021
Weighted Assessment 3

NAME : _____ ()

DATE : _____

CLASS : _____

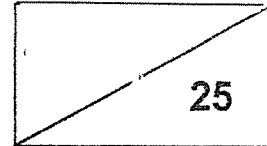

PARENT'S SIGNATURE : _____

Section A

Questions 1 to 4 carry 2 mark each. For each question, four options are given. One of them is the correct answer. Make your choice (1, 2, 3 or 4) and write your choice in the bracket provided. All diagrams are not drawn to scale. (8 marks)

1. What is the value of the digit 7 in 38.479?

(1) 7

(2) 0.7

(3) 0.07

(4) 0.007

()

2. Arrange the following decimals in decreasing order.

6.49 , 6.049 , 6.409 , 6.904

(1) 6.904 , 6.49 , 6.409 , 6.049

(2) 6.904 , 6.409 , 6.49 , 6.049

(3) 6.049 , 6.409 , 6.49 , 6.904

(4) 6.049 , 6.49 , 6.409 , 6.904

()

3. How many one-fifths are there in $1\frac{3}{5}$?

(1) 5

(2) 8

(3) 3

(4) 9

()

4. Cindy bought $\frac{5}{8}$ kg of sugar. She bought $\frac{1}{4}$ kg more flour than sugar.
How many kilograms of flour did Cindy buy?

(1) $\frac{1}{2}$ kg

(2) $\frac{3}{4}$ kg

(3) $\frac{3}{8}$ kg

(4) $\frac{7}{8}$ kg

()

Section B

Do not write
in this space

Questions 5 to 9 carry 2 marks each. Show your working clearly and write your answers in the spaces provided. For questions which require units, give your answers in the units stated. All diagrams are not drawn to scale. (10 marks)

5. $10 + 8 + 0.7 + \underline{\quad ? \quad} + 0.009 = 18.749$

What is the missing number?

Ans: _____

6. Round 13.592 to the nearest whole number.

Ans: _____

7. Find the missing mixed number in the following number line.

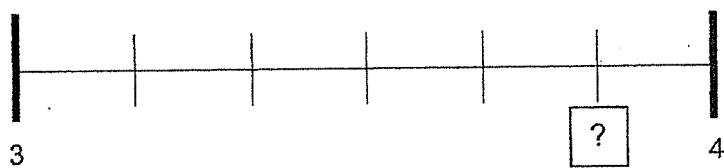

Do not write
in this space

Ans: _____

8. What is the sum of 21.73 and 4.98?

Ans: _____

9. Arrange the following fractions in ascending order.

$$\frac{4}{7}, \frac{17}{12}, 3\frac{1}{2}, \frac{1}{2}$$

Ans: _____

SECTION C

For Questions 10 to 11, show your working clearly and write your answers in the spaces provided. The number of marks available is shown in brackets [] at the end of each question or part-question. All diagrams are not drawn to scale.

(7 marks)

Do not write
in this space

10. Ahmad had some stickers.

He lost $\frac{2}{5}$ of the stickers and had 27 stickers left.

How many stickers did Ahmad have at first?

Ans: _____ [3]

11. Mrs Tan bought some juice.

She drank $\frac{5}{12}$ l of juice and gave away $\frac{1}{3}$ l of it.

She was left with $\frac{7}{12}$ l of juice.

- (a) How many more litres of juice did she drink than she give away?
(b) How many litres of juice did Mrs Tan buy?

Give your answer as a mixed number in simplest form.

Do not write
in this space

Ans: (a) _____ [2]

(b) _____ [2]



END OF PAPER

Catholic High School (Primary)
Primary 4 Mathematics Practice

NAME : _____ ()

DATE : _____

CLASS : _____

PARENT'S SIGNATURE : _____

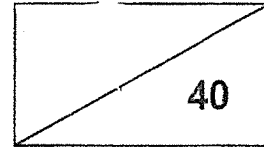

Section A

Questions 1 to 6 carry 2 marks each. For each question, four options are given. One of them is the correct answer. Make your choice (1, 2, 3 or 4) and write your choice in the bracket provided. All diagrams are not drawn to scale. (12 marks)

1. In the number 43.21, which digit is in the tenths place?

(1) 1

(2) 2

(3) 3

(4) 4

()

2. Which of the following is a multiple of both 6 and 8?

(1) 12

(2) 2

(3) 16

(4) 24

()

3. Which of the following is **not** a factor of 12?

(1) 8

(2) 2

(3) 3

(4) 4

()

4. Study the map below carefully.

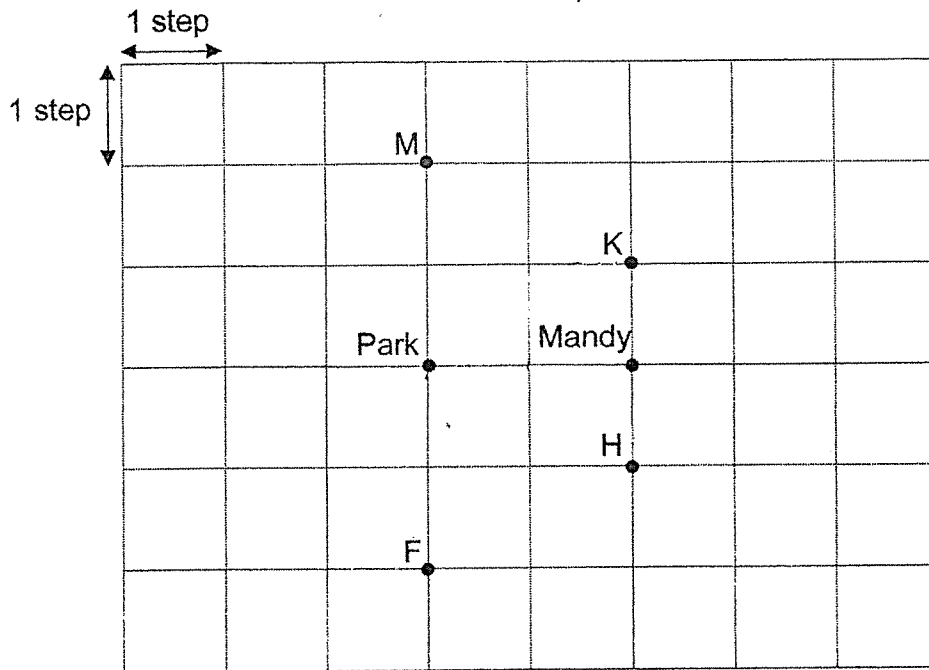

Mandy was facing the park. She made a $\frac{1}{4}$ -turn in a clockwise direction.
Which point was she facing at the end?

- (1) F
- (2) H
- (3) K
- (4) M ()

5. Abby saved 5 times as much as Ben. They saved \$4860 altogether.
How much did Ben save?

- (1) \$810
- (2) \$972
- (3) \$4855
- (4) \$4865 ()

6. Find the perimeter of the following figure. (All lines meet at right angles)

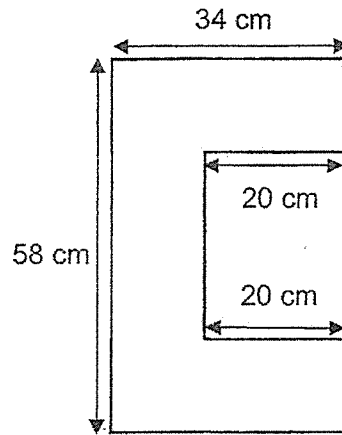

- (1) 160 cm
- (2) 184 cm
- (3) 204 cm
- (4) 224 cm

()

Section B

Do not write
in this space

Questions 7 to 14 carry 2 marks each. Show your working clearly and write your answers in the spaces provided. For questions which require units, give your answers in the units stated. All diagrams are not drawn to scale. (16 marks)

7. Write the missing number in the number pattern below.

14 200 , 14 100 , 14 000 , _____ ? _____ , 13 800 , 13 700

Ans: _____

8. Express $3\frac{1}{50}$ as a decimal.

Ans: _____

9. Find the value of $1 - \frac{1}{3} - \frac{7}{12}$

Do not write
in this space

Ans: _____

10. The table below shows the favourite food of all the pupils in 2 classes. Each pupil chose only 1 favourite food.

Class	Burgers	Fried Rice	Pizza
4X	13	18	12
4Y	21	6	11

Each of the statements below is either true, false or not possible to tell from the information given. For each statement, put a tick (✓) to indicate your answer.

	Statement	True	False	Not possible to tell
(a)	The total number of pupils in 4X is more than the total number of pupils in 4Y.			
(b)	Least number of pupils chose fried rice as their favourite food.			

11. Dayrus paid \$9.60 for 5 pens and a marker. 1 marker cost thrice as much as a pen. How much did a pen cost?

Do not write in this space

Ans: \$ _____

12. Measure and write down the size of $\angle x$.

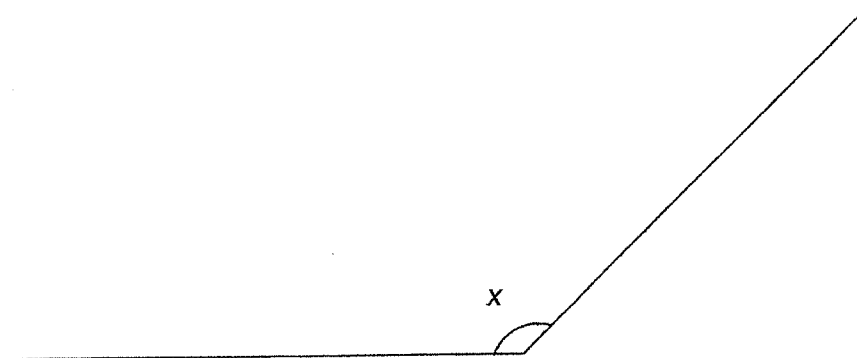

Ans: _____ °

13. In the square grid below, shade two unit squares so that the dotted line is a line of symmetry.

Do not write in this space

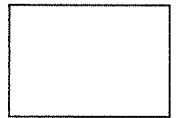
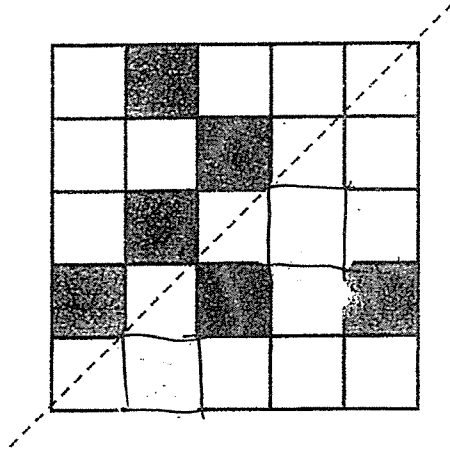

14. In the square grid below, draw rectangle ABCD from the given lines.

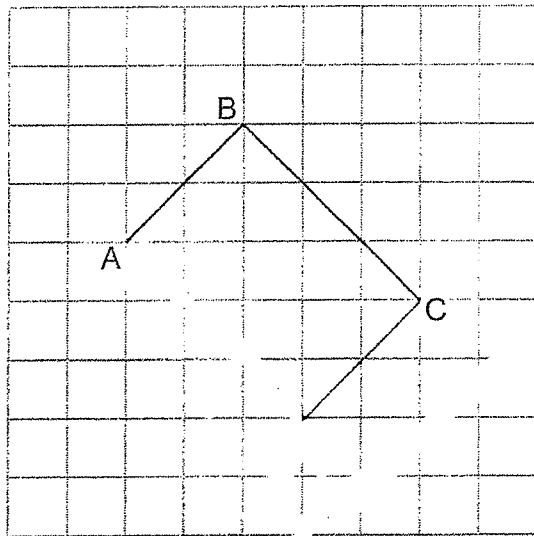

Section C

Do not write
in this space

For Questions 15 to 17, show your working clearly and write your answers in the spaces provided. The number of marks available is shown in brackets [] at the end of each question or part-question. All diagrams are not drawn to scale.
(12 marks)

15. Larry had 35 more cookies than Kenny. Matthew had twice the total number of cookies that Larry and Kenny had. The 3 boys had 717 cookies altogether. How many cookies did Kenny have?

Ans: _____ [4]

16. Ethan had some money at first. He spent $\frac{4}{9}$ of it on a meal and \$58 on groceries. He then had \$72 left.

(a) How much money did he have at first?

(b) How much money did he spend on the meal?

Do not write
in this space

Ans: (a) _____ [2]

(b) _____ [2]

17. The total mass of a container and a watermelon was 2.36 kg. When some oranges were put into the container, the total mass became 3.26 kg. The mass of the watermelon was twice the mass of all the oranges.
- (a) Find the mass of the watermelon.
- (b) Find the mass of the container. Give your answer in kilograms.

Do not write
in this space

Ans: (a) _____ [2]

(b) _____ [2]

END OF PAPER

ANSWER KEY

YEAR : 2021
LEVEL : Primary 4
SCHOOL : Catholic High School
SUBJECT : MATHEMATICS
TERM : Weighted Assessment 1

Section A

Q1	4	Q2	3	Q3	1	Q4	2
----	---	----	---	----	---	----	---

Section B

Q5	$50870-100=50770$	Q6	24
Q7	$24 \times 20 = 480$ $480+10=490$	Q8	$52 \div 9 = 5R7$ $45+7=52$
Q9	$5350 \div 5 = 1070$		

Section C

Q10	(multiples of 3)+1= 1,4,7,10,13,16,19 (multiples of 7) + 5 = 12,19,26,33 Common multiple= 19 Ans : 19	Q11	$5780 \div 4 = 1445$ $1445 \times 3 = 4335$ $4335+1200=5535$
-----	---	-----	--

Electronic Multiple Choice Questions eMCQ at www.sgtestpaper.com

ANSWER KEY

YEAR : 2021
LEVEL : Primary 4
SCHOOL : Catholic High School
SUBJECT : MATHEMATICS
TERM : Weighted Assessment 3 & Mathematics Practice

Weighted Assessment 3

Section A

Q1	3	Q2	1	Q3	2	Q4	4
----	---	----	---	----	---	----	---

Section B

Q5	$18.749 - 10 - 8 - 0.7 - 0.009 = 0.04$	Q6	14
Q7	$3\frac{5}{6}$	Q8	26.71
Q9	$\frac{1}{2}, \frac{4}{7}, \frac{17}{12}, 3\frac{1}{2}$		

Section C

Q10	$1 - \frac{2}{5} = \frac{3}{5}$ $27 \div 3 = 9$ $5 \times 9 = 45$	Q11	$(a) \frac{5}{12} - \frac{1}{3} = \frac{1}{12} \ell$ $(b) \frac{5}{12} + \frac{4}{12} = \frac{9}{12}$ $\frac{9}{12} + \frac{7}{12} = \frac{16}{12}$ $\frac{16}{12} = 1\frac{1}{3} \ell$
-----	---	-----	--

Mathematics Practice

Section A

Q1	2	Q2	4	Q3	1	Q4	3	Q5	1
Q6	4								

Section B

Q7	$14000 - 100 = 13900$	Q8	3.02
Q9	$\frac{1}{12}$	Q10	(a) True (b) False
Q11	$9.60 \div 8 = \$1.20$	Q12	136°

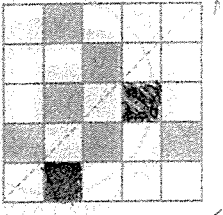
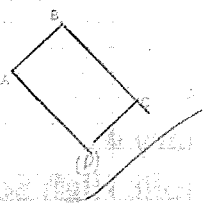
Q13		Q14	
-----	---	-----	--

Section C

Q15	$35 \times 3 = 105$ $717 - 105 = 612$ $612 \div 6 = 102$	Q16	<p>(a) $58 + 72 = 130$</p> $1\frac{4}{9} = \frac{5}{9}$ $130 \div 5 = 26$ $26 \times 9 = \$234$ <p>(b) $26 \times 4 = \\$104$</p>
Q17	<p>(a) $3.26 - 2.36 = 0.9$</p> $0.9 + 0.9 = 1.8\text{kg}$ <p>(b) $1.8 + 0.9 = 2.7$</p> $3.26 - 2.7 = 0.56\text{kg}$		

3
END