

NANYANG PRIMARY SCHOOL

PRIMARY 3 SCIENCE

2021

Practice Paper

BOOKLET A

Name : _____ ()

Class: Primary 3 ()

Booklet A consists of 13 printed pages including this cover page.



Section A

For each question from 1 to 22, four options are given. One of them is the correct answer. **Indicate your choice in this booklet and shade the correct oval (1, 2, 3 or 4) on the Optical Answer Sheet provided.**

1. Study the classification chart below.

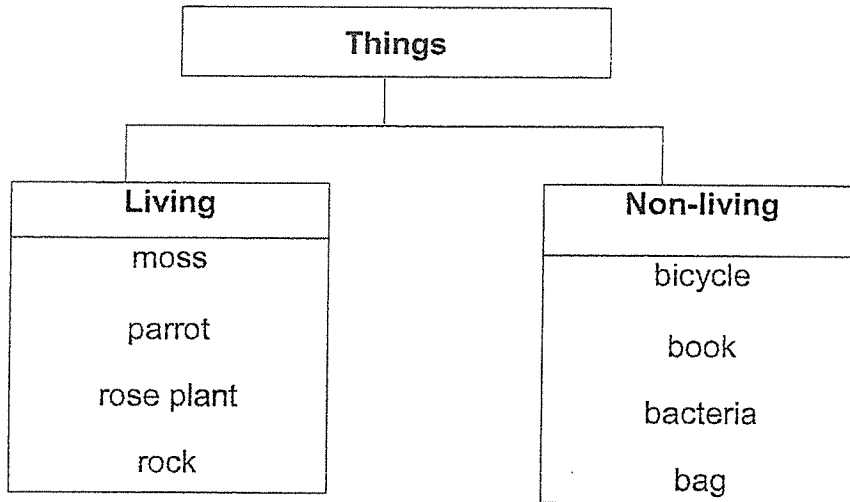

Which of the following have been placed in the **wrong** group?

- (1) moss and book
 - (2) rock and bag
 - (3) moss and bacteria
 - (4) rock and bacteria
- (4)

2. Mrs Rosnah placed a healthy potted flowering plant beside the window of her house for two weeks. The diagram below shows the plant with dried flowers and leaves after two weeks.

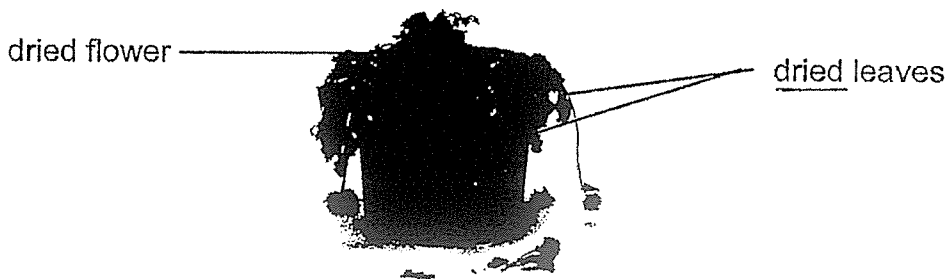

Which one of the following is the most likely reason for the flowers and leaves to become **dried**?

- (1) The plant did not get enough air.
- (2) The plant did not get enough light.
- (3) The plant did not get enough water.
- (4) The plant did not get enough warmth.

3. Which of the following statements are characteristics of adult reptiles?

- A They reproduce by laying eggs.
- B They have fins to help them swim.
- C They have dry skin usually covered with scales.

- (1) A and B only
- (2) A and C only
- (3) B and C only
- (4) A, B and C

4. Which of the following statements about the characteristics of bacteria is/are correct?

- A All bacteria are harmful to us.
- B All bacteria can make their own food.
- C All bacteria can only be seen through a microscope.

- (1) C only
- (2) A and B only
- (3) A and C only
- (4) B and C only

5. Study the diagram below.

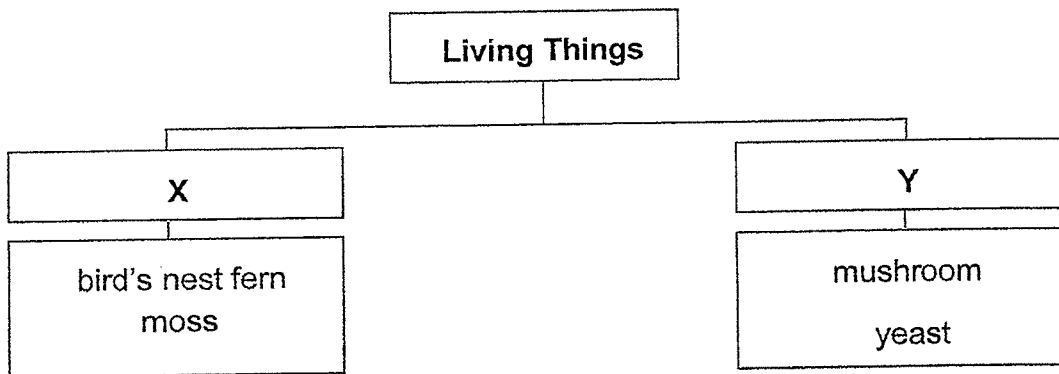

Which of the following correctly represents the headings X and Y?

	X	Y
(1)	Reproduce by seeds	Reproduce by spores
(2)	Non-flowering plant	Flowering plant
(3)	Grow on land	Grow in water
(4)	Plant	Fungi

6. Study the flowchart below.

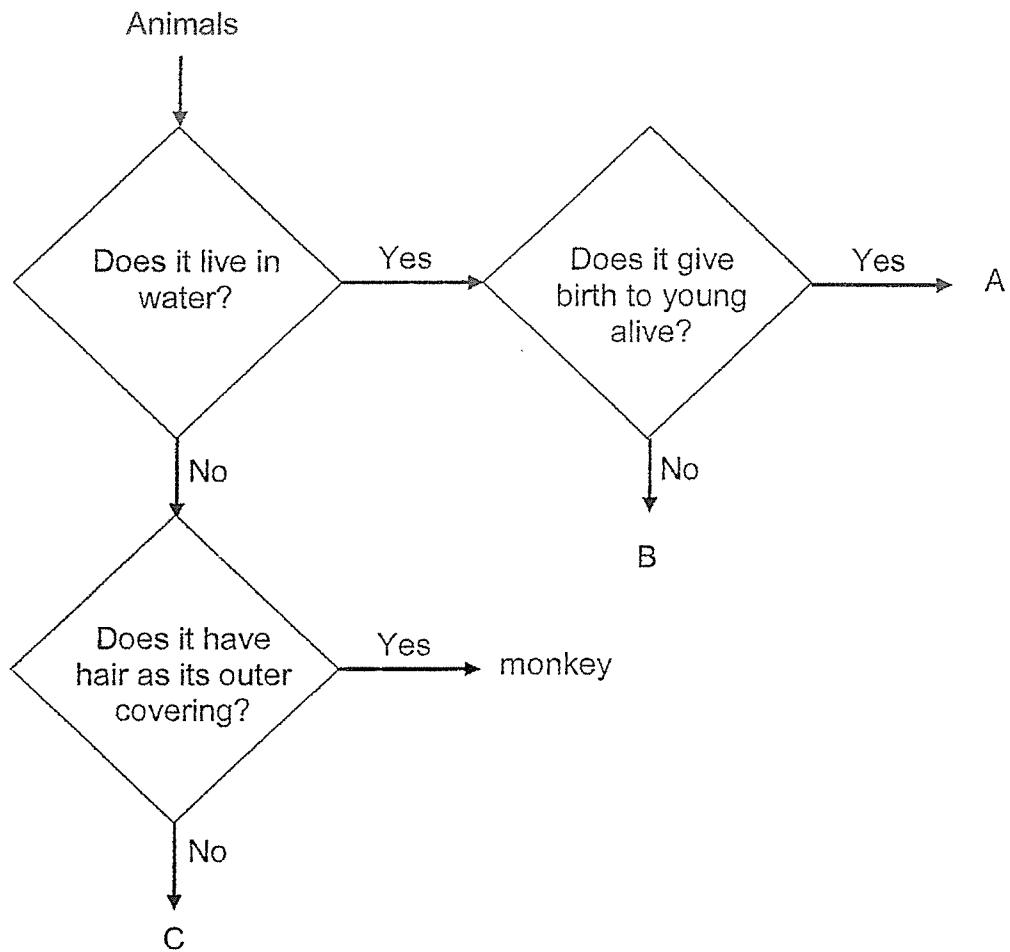

Based on the flowchart above, which one of the following could represent animals A, B and C correctly?

	A	B	C
(1)	goldfish	crocodile	salamander
(2)	dolphin	goldfish	butterfly
(3)	dolphin	butterfly	crocodile
(4)	goldfish	crocodile	butterfly

7. Study the diagram below.

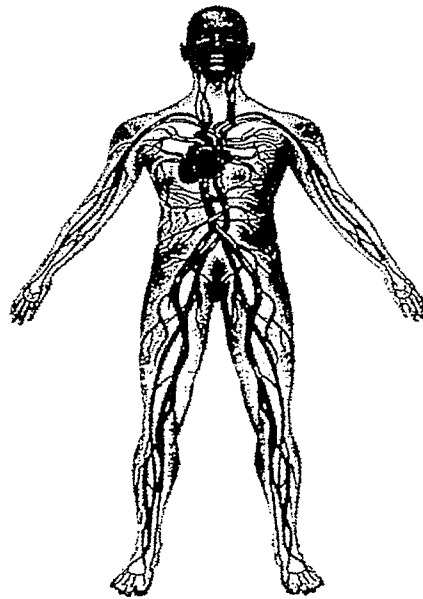

Which human system does the above diagram represent?

- (1) digestive system
- (2) muscular system
- (3) circulatory system
- (4) respiratory system

8. Which one of the following statements about the human system is correct?

	Human Systems	Functions
(1)	Skeletal	Protects important organs in our bodies
(2)	Muscular	The heart pumps blood throughout the body
(3)	Respiratory	Works with skeletal system to help us to move
(4)	Circulatory	Helps the body to take in and give out air

9. Which one of the following statements about the human digestive system is **wrong**?

- (1) The stomach produces digestive juices.
- (2) The large intestine removes water from the undigested food.
- (3) The stomach and the small intestine digest most of the food.
- (4) The human digestive system transports digested food and oxygen to other parts of the body.

10. Dominic conducted an experiment as shown in the diagram below to test the strength of different materials. Weights of identical mass were added to the strings until each of the string broke. Then he recorded the number of weights added till the strings broke. The strings used were of the same thickness but made of different materials, W, X, Y and Z.

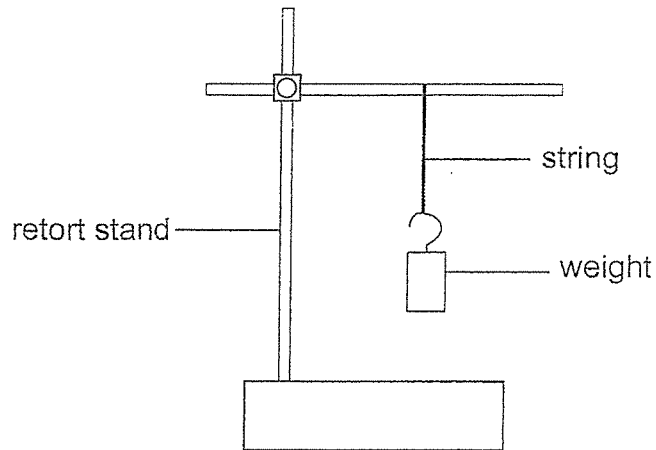

The graph below shows his results.

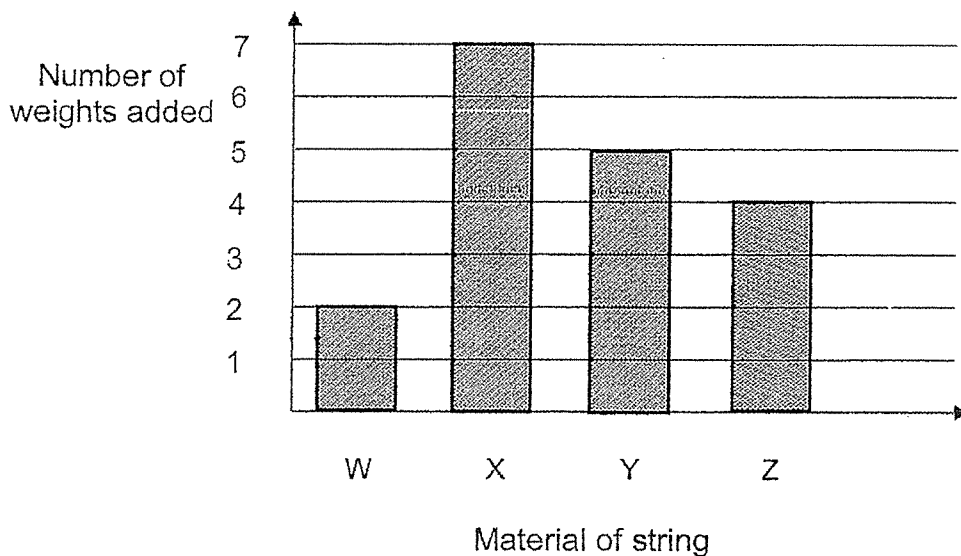

Based on Dominic's results above, which one of the following statements is correct?

- (1) X is the weakest material.
- (2) W is the strongest material.
- (3) Y is a stronger material than Z.
- (4) Z could support more weights than X before it broke.

11. Matthew observed and recorded four properties of object P as shown below.

- Object P is stiff.
- Object P sinks in water.
- Object P does not break easily.
- Object P does not allow light to pass through it.

Based on the properties above, which one of the following best represents object P?

- (1) metal cup
- (2) paper boat
- (3) rubber band
- (4) wooden chopsticks

12. Firefighters wear clothing made of special materials when they put out fires.

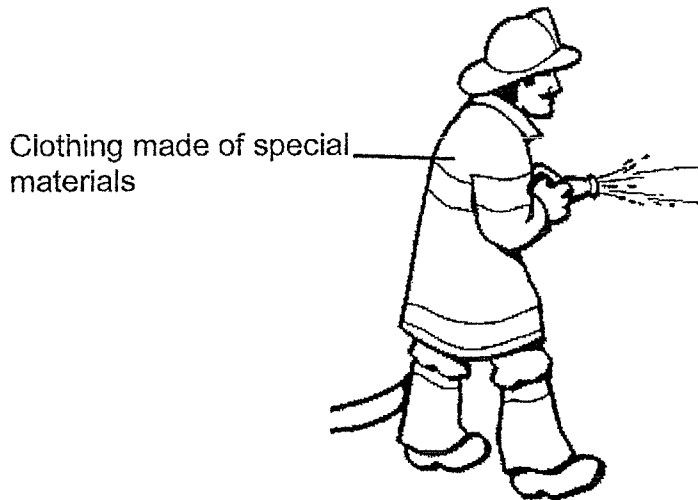

Based on the properties of materials A, B, C, and D as shown below, which one of the materials is the most suitable for making the firefighter's clothing? A tick (✓) shows that the material has that property.

	Material	Property		
		strong	flexible	waterproof
(1)	A	x	✓	x
(2)	B	✓	x	✓
(3)	C	✓	✓	✓
(4)	D	✓	✓	x

13. Xavier uses his pair of goggles to help him see clearly under the water.

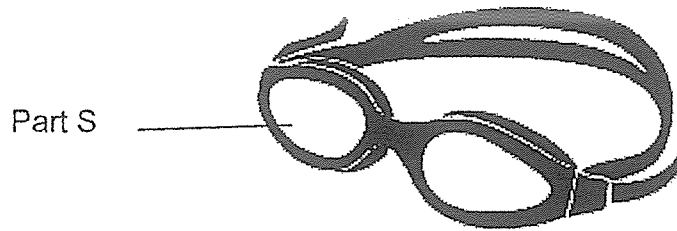

Which of the following correctly states the properties that part S should have?

	Allow light to pass through it	Waterproof
(1)	yes	no
(2)	yes	yes
(3)	no	yes
(4)	no	no

14. Which one of the following objects is made of a magnetic material?

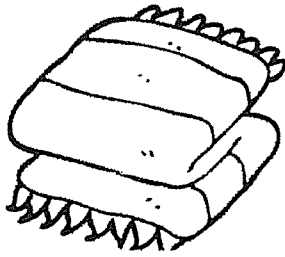

(1) cotton towel



(2) plastic bottle

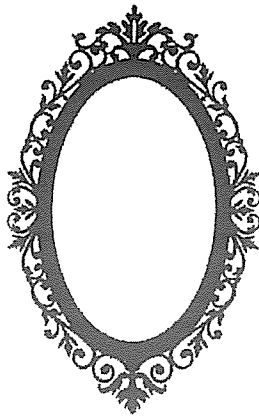

(3) wooden mirror frame

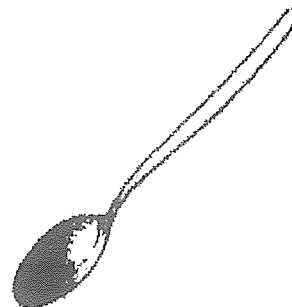

(4) steel spoon

15. Study the diagrams carefully. Both bars A and B are magnets.

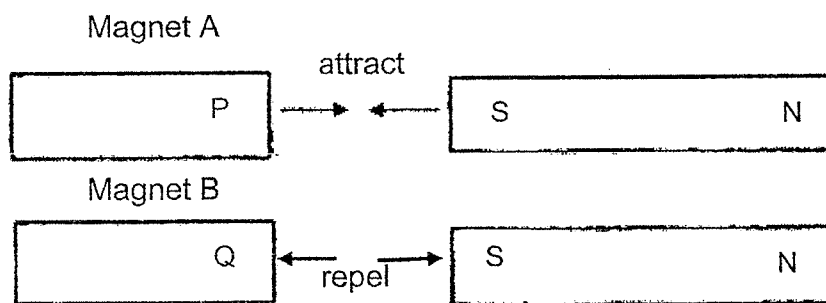

Magnets A and B are held in the same position without being released and then brought close to each other as shown in the diagram below.



What will be observed when Magnets A and B are brought close together in the positions shown above?

- (1) Magnet A and Magnet B will repel each other.
 - (2) Magnet A and Magnet B will attract each other.
 - (3) Magnet A and Magnet B will attract first and then repel each other.
 - (4) Magnet A and Magnet B will repel first and then attract each other.
16. Gemma brought both poles of a magnet near three objects, X, Y and Z. Each object is made of different materials. She then recorded the type of interaction between the magnet and objects in the table below.

Objects	Type of Interaction with magnet		
	Attract	Repel	No movement
X	✓		
Y	✓	✓	
Z			✓

Which one of the following statements is correct about objects X, Y and Z?

- (1) Objects X and Y are magnets.
- (2) Objects X and Y are made of non-metals.
- (3) Objects, X, Y and Z, are made of magnetic materials.
- (4) Object Y is a magnet and object Z is made of non-magnetic material.

17. Three magnets, J, K and L, were brought near to each other. Magnet J was observed to move away from magnet K but magnet J was attracted to magnet L as shown in the diagram below.

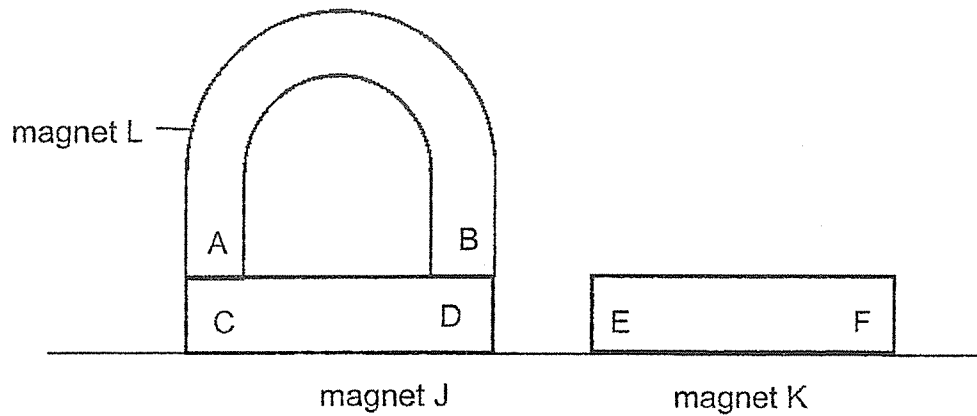

Based on the diagram above, which one of the following statements **incorrectly** describes the poles of the magnets?

- (1) Poles B and F are like poles.
 - (2) Poles C and E are like poles.
 - (3) Poles A and C are unlike poles.
 - (4) Poles D and F are unlike poles.
18. Alicia held a bar magnet above a plastic container of iron nails. She then lowered it into the container.

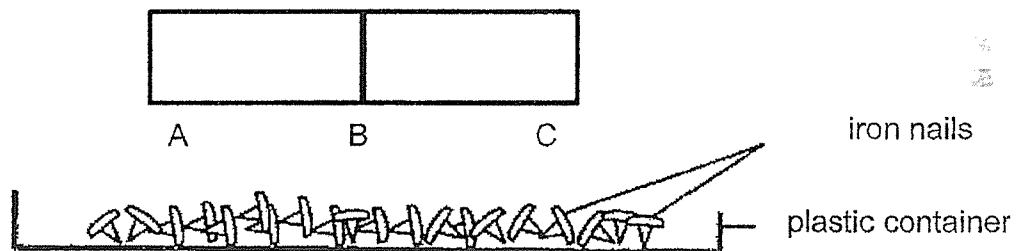

Which of the following shows the likely results for the number of iron nails attracted by parts A, B and C of the bar magnet?

	A	B	C
(1)	10	10	5
(2)	5	10	10
(3)	5	2	15
(4)	10	5	10

19. Lyndon magnetised four identical iron bars, W, X, Y and Z, using the stroke method. He observed that the iron bars were able to attract the paper clip from different distances as shown in the diagram below.

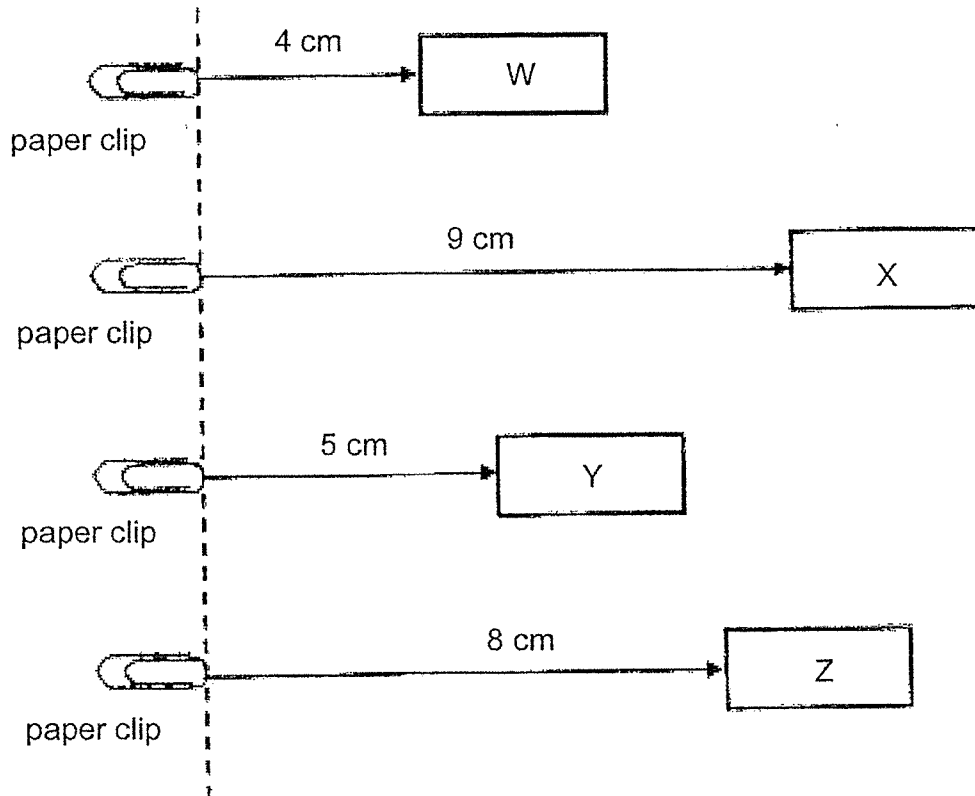

Which iron bar had been stroked the most number of times?

- (1) W
- (2) X
- (3) Y
- (4) Z

20. Christie coiled a length of wire around an iron rod and connected it to a battery.
In which one of the following set-ups would the electromagnet have the greatest magnetic strength?

(1)

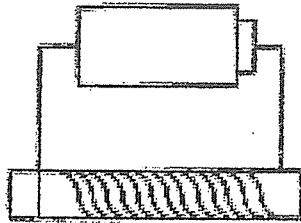

13 coils

(2)

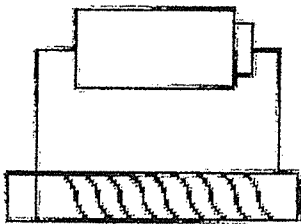

9 coils

(3)

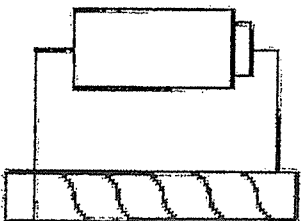

5 coils

(4)

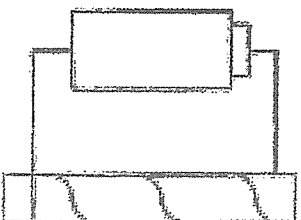

3 coils

21. Which of the following objects make use of magnets to work?

- A torch
- B compass
- C kettle
- D refrigerator

- (1) A and C only
- (2) A and D only
- (3) B and D only
- (4) A, B and C only

22. The diagram below shows two toy cars, A and B. Each toy car has a bar magnet fixed on it. The diagram shows the interaction between compass X and the bar magnet on car A. When the two toy cars were brought close to each other, they moved towards each other.

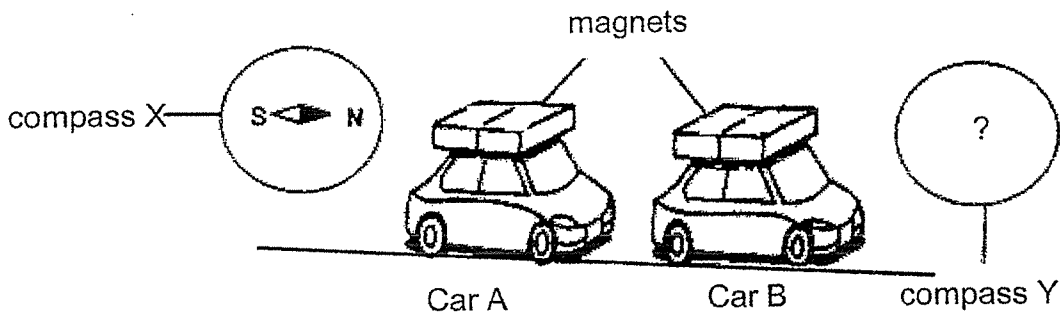

Which one of the following diagrams shows the correct position of the needle of compass Y?

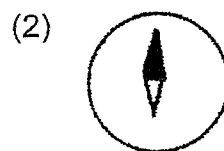

~ END OF BOOKLET A ~

NANYANG PRIMARY SCHOOL

PRIMARY 3 SCIENCE

2021

PRACTICE PAPER

BOOKLET B

Name : _____ ()

Class: Primary 3 ()

Booklet B consists of 10 printed pages including this cover page.

Section B

Write your answers to questions 23 to 31 in the spaces provided.

23. Study the classification chart below.

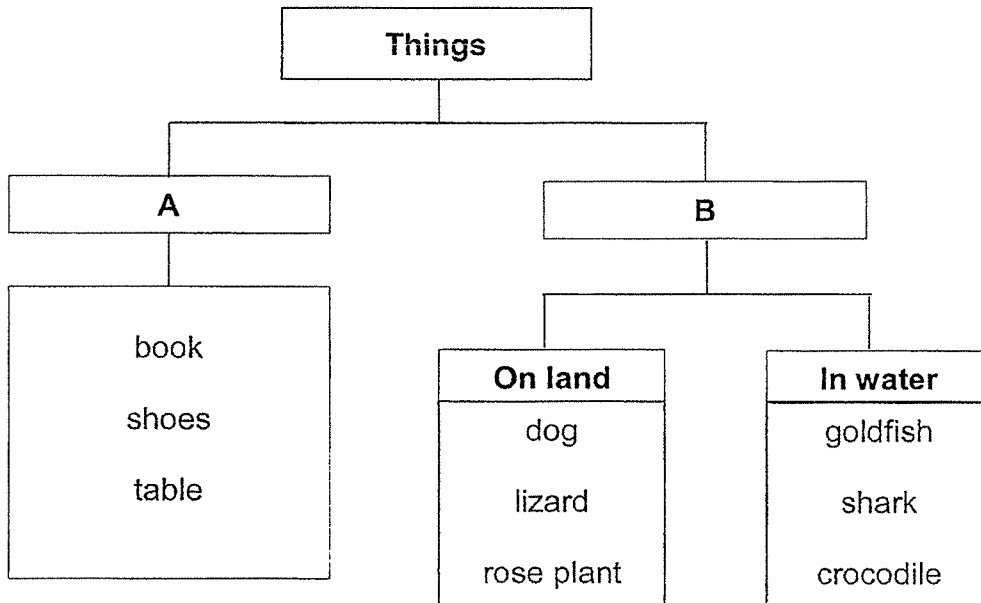

(a) Based on the classification chart above, state the possible headings for **A** and **B**. [1]

(i) A: _____

(ii) B: _____

(b) Alex said that both the book and the rose plant cannot move on its own. Therefore, rose plant should be classified in Group A. Show comparison to explain why Alex was **wrong**. [1]

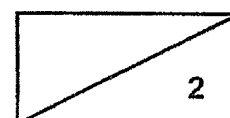

24. Ahmad was walking in the park and saw two different living things, X and Y, as shown in the diagram below.

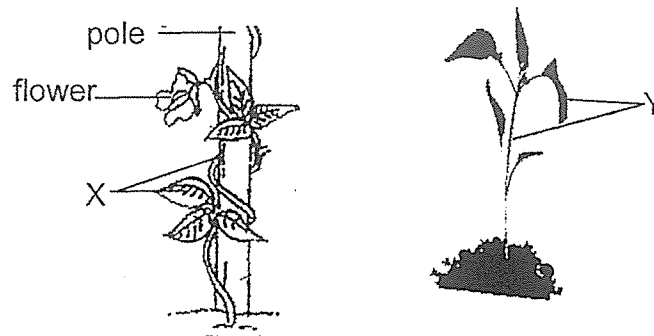

- (a) Based on the diagram, state one similarity between X and Y. [1]

- (b) Based on the diagram, state one difference between X and Y. [1]

25. Brendon was packing his school bag and found a bun which he had forgotten for a week. He noticed that green patches of mould had grown on the bun.

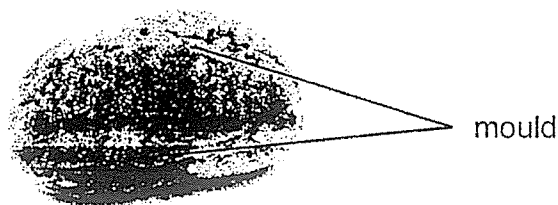

- (a) State all the conditions that had enabled the mould to grow well in his school bag. [1]

- (b) State where the mould had obtained its food. [1]

26. The table below shows the characteristics of three animals, J, K and L. A tick (✓) shows that the animal has the characteristics.

Characteristics	Animals		
	J	K	L
Breathes through its moist skin.	✓		
Has six legs.		✓	
Reproduces by laying eggs.	✓	✓	
Lives on land.		✓	✓

- (a) Based on the table above, state the animal **group** for animals J and L. [1]

Animal J: _____

Animal L: _____

- (b) Based on the characteristics of the animals in the table above, state one difference between animal J and animal L. [1]

- (c) State the outer covering of animal K and its function. [1]

Outer covering: _____

Function of this outer covering:

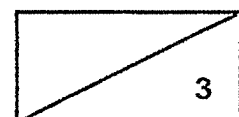

27. The diagram below shows the human digestive system.

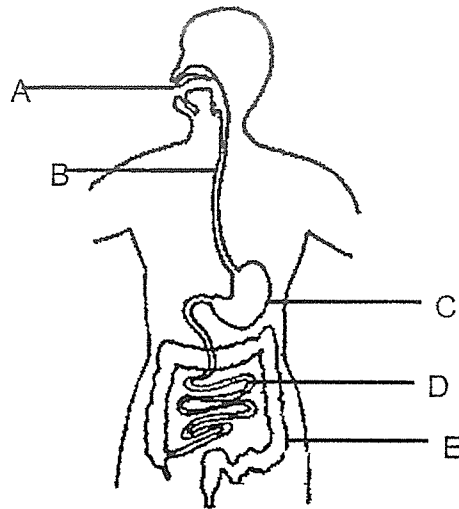

(a) State the two functions of the human digestive system. [1]

(i) _____

(ii) _____

No digestion takes place in some parts of the human digestive system.

(b) (i) State one part (A, B, C, D or E) where no digestion takes place. [1]

(ii) Besides no digestion taking place, state another function of the part mentioned in (b)(i). [1]

(c) (i) Identify part D. [1]

(iii) How is digestion affected if part D is removed from the human digestive system? [1]

28. Gavin conducted an experiment using two balls made of different materials, A and B. He placed the two balls into a tank of water. The results are as shown below.

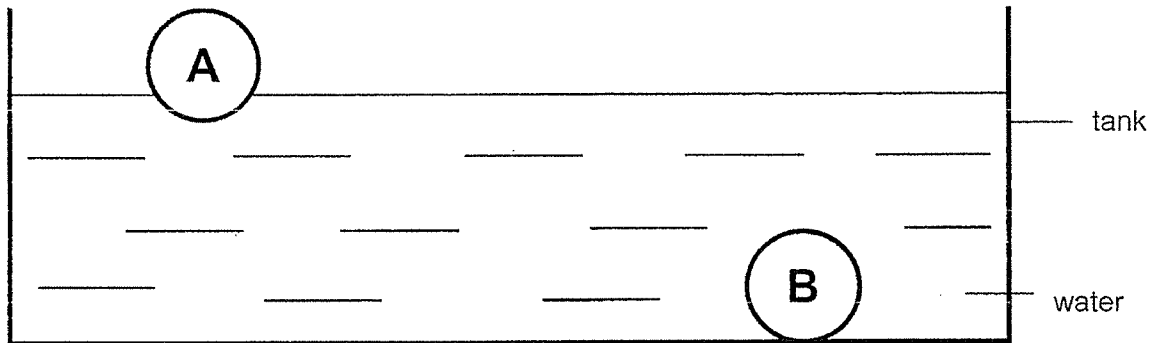

- (a) What property of the materials was he testing for? [1]

The diagram below shows Gavin swimming with a kickboard.

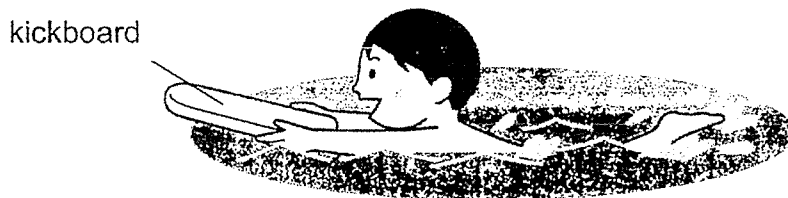

- (b) i) Which material, A or B, is more suitable for making a kickboard for swimming? [1]

- (b) ii) Explain your answer. [1]

29. Jolyn wanted to find out which material makes a good bag that does not tear easily when she carries a lot of things. She used four identical bags, A, B, C and D, made of different materials as shown below. She then added metal balls into each of the bags until the bag was torn.

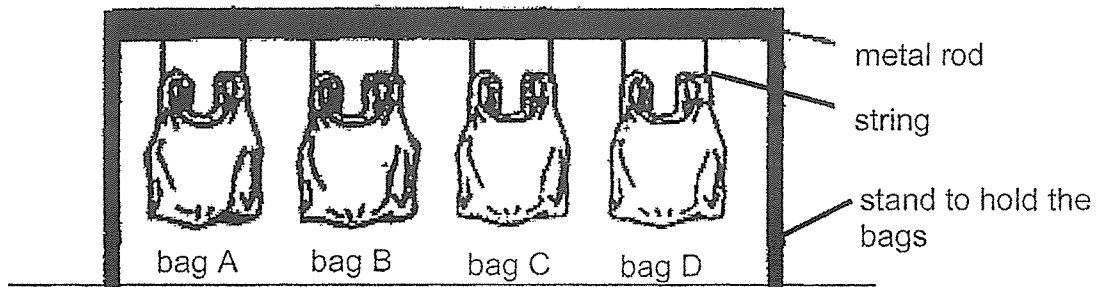

She recorded her observation in the bar graph below.

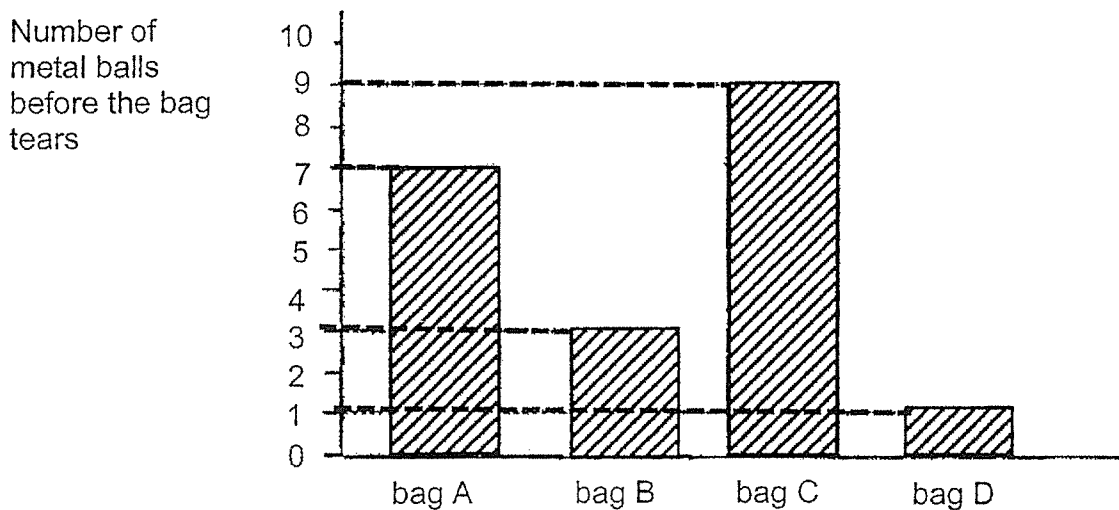

- (a) State the property that Jolyn was testing for. [1]

- (b) (i) Which bag is the most suitable for her to carry the most number of items? [1]

- (ii) Explain your answer. [1]



30. A nail can be made into a temporary magnet by stroking it with a strong magnet as shown in the diagram below.

- (a) Complete the diagram below by drawing arrows to show the circular movement of the strokes. [1]

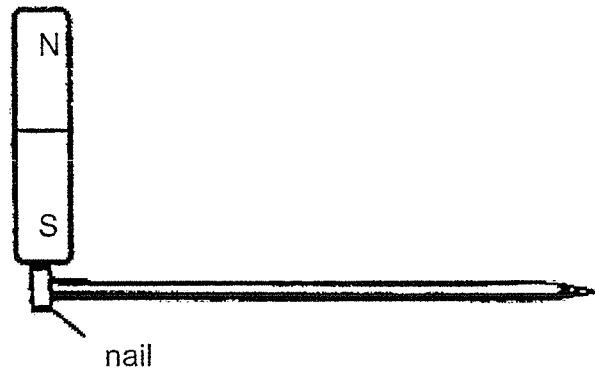

Ronald wants to magnetise a copper bar using one of the poles of the bar magnet. However, no matter how many times he stroke the copper bar, it is not able to attract any steel paper clips.

- (b) Suggest a change he should do so that the steel paper clips can be attracted. Explain your answer. [2]

(i) Change to the setup: _____

(ii) Reason for the change:

31. Raymus carried out an experiment to find out how the number of similar magnets stacked together will affect the number of paper clips attracted to the magnets from a fixed distance.

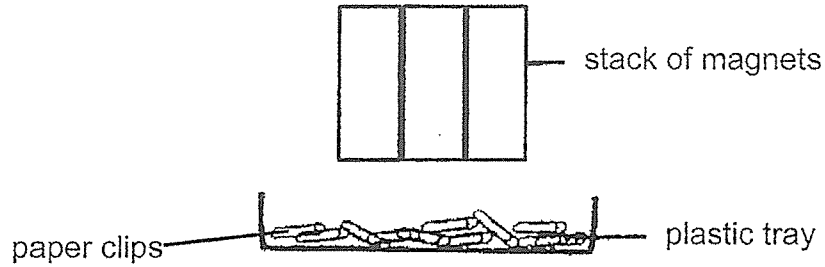

The table below shows the results of his experiment.

Number of magnets stacked together	Number of paper clips attracted to the magnet
1	2
2	5
3	(a) <input type="text"/>
4	8

- (a) Fill in the table with a suitable number of paper clips that are most likely attracted to the magnets when 3 magnets are stacked together.

[1]

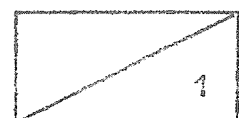

A scientist carried out an experiment using a special machine to separate steel scraps from plastic chip as shown in the diagram below.

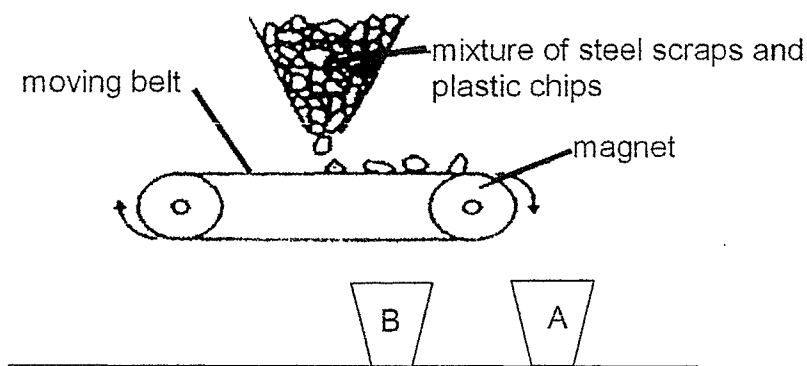

(b) Which of the materials, steel scraps and plastic chips, are most likely to be found in containers A and B? Give a reason for each answer.

(i) Container A: _____ [1]

Reason for Container A:

(ii) Container B: _____ [1]

Reason for Container B:

~ END OF BOOKLET B ~

ANSWER KEY

YEAR : 2021
LEVEL : Primary 3
SCHOOL : Nanyang Primary School
SUBJECT : SCIENCE
TERM : Practice Paper

BOOKLET A

Q1	4	Q2	3	Q3	2	Q4	1	Q5	4
Q6	2	Q7	3	Q8	1	Q9	4	Q10	3
Q11	1	Q12	3	Q13	2	Q14	4	Q15	1
Q16	4	Q17	2	Q18	4	Q19	2	Q20	1
Q21	3	Q22	3						

BOOKLET B

Q23	(a) (i) Non-living things (ii) Living things (b) Rose plant can move part of itself on its own but the book cannot move at all, so rose plant is a living thing, grouped in Group B.
Q24	(a) X and Y have stems and leaves. (b) X has flowers but Y does not.
Q25	(a) It had warmth and water. (b) The mould got its own food from the bun that it is growing on.
Q26	(a) Animal J : amphibian Animal L : mammal (b) J breathe through its moist skin but L does not breathe through its moist skin. (c) Outer covering : hard outer-covering Function of this outer covering : protects its body parts.
Q27	(a)(i) Breaks food into siple substances. (ii) It absorbs digested food into the blood. (b)(i) B (ii) E absorbs water from undigeted food. (c) (i) small intestine (ii) Digestion cannot be completed.
Q28	(a) Able to float or sink (b) (i) A (ii) A is more suitable because it floats on water so that Gavin will stay afloat while swimming.

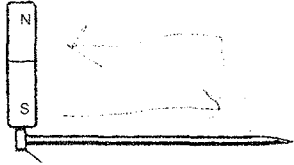
Q29	<p>(a) Strength</p> <p>(b) (i) Bag C</p> <p>(ii) Bag C is able to hold the most number of metal balls before it tears so it is the strongest and so that Jolyn can carry the most number of items with the bag without tearing.</p>
Q30	 <p>(a)</p> <p>(b) (i) change the copper bar into a iron bar.</p> <p>(ii) Copper bar is not magnetic since its made of a non-magnetic material, thus even if it is stroked many times it would not be magnetised. Changing to iron bar because iron is a magnetic material thus being able to be magnetised .</p>
Q31	<p>(a) 7</p> <p>(b) (i) Container A : plastic chips</p> <p>Reason for conatiner A : The plastic chips are not magnetic and will not ba attracted to the magnet thus dropping into container A.</p> <p>(ii) Container B steel scraps</p> <p>Reason for Container B : The steel scraps are magnetic and will be attracted to the magnet and will stay attracted to the magnet until the magnet cannot attract it so it will drop in container B.</p>