



**NAN HUA PRIMARY SCHOOL
CONTINUAL ASSESSMENT 1 2015
PRIMARY SIX
SCIENCE**

Name : _____ ()

Class : Primary 6 / _____

Date : 4 March 2015

Duration : 1 hr 45 min

MARKS	
Sect A:	/ 60
Sect B:	/ 40
Total :	/ 100

Parent's Signature : _____

Section A: (30 x 2marks = 60marks)

For each question from 1 to 30, four options are given. One of them is the correct answer. Make your choice (1, 2, 3 or 4). Shade the correct oval (1, 2, 3 or 4) on the Optical Answer Sheet.

1. The table below shows the estimated daily energy required by different types of activity.

Types of activity	Estimated daily amount of energy required (Unit of energy/day)
Sleeping	19
Reading	24
Sitting	35
Climbing up a stair	100
Running	135
Rock wall climbing	174

Which one of the following cannot be concluded from the data above?

- (1) The type of activity affects the amount of energy required.
- (2) The more rigorous the activity, the more energy is required.
- (3) Energy is required by living things to perform different tasks.
- (4) The younger the person, the more energy is required to perform an activity.

2. Which of the following statements about energy are true?

- A The sun is not our main source of energy.
- B Living and non-living things need energy to work.
- C Plants are directly dependent on the Sun for energy.
- D Heat energy from the Sun keeps the water cycle going.

- (1) A and D only
- (2) B and C only
- (3) A, B and C only
- (4) B, C and D only

3. A ball at A is given a push and travels as shown in the diagram below.

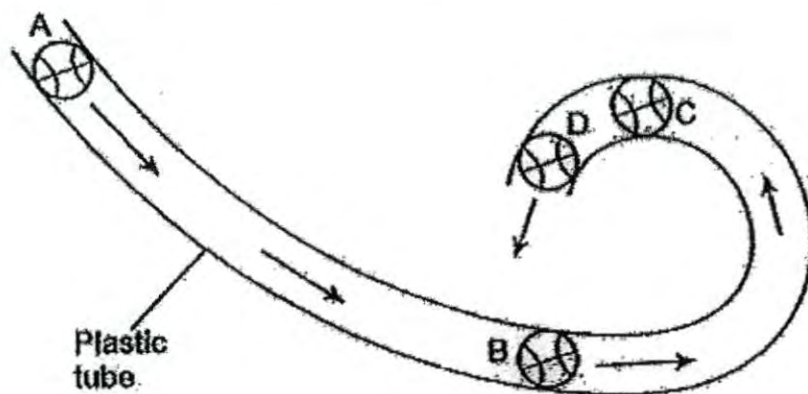

Which of the following statement(s) about the ball is/are true?

- A The ball slows down as it travels from B to C.
- B The ball has more amount of matter in it when it is at B than at C.
- C The ball has different amount of gravitational potential energy when it is at A, B, C and D.

- (1) B only
- (2) A and C only
- (3) B and C only
- (4) A, B and C

4. Which one of the following statements is **Incorrect**?

- (1) A force is a push or a pull.
- (2) A force can slow down a moving object.
- (3) A force can change the speed of a moving object.
- (4) A force cannot change the direction of a moving object.

5. The diagram below shows two identical balls, P and Q.

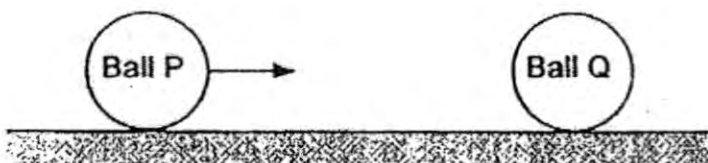

Ball Q is stationary while Ball P rolling on the floor towards Ball Q. What will happen to Ball Q when Ball P hits it ?

- (1) Ball Q will increase speed.
 - (2) Ball Q will remain stationary.
 - (3) Ball Q will move in the same direction as Ball P
 - (4) Ball Q will move in the opposite direction of Ball P.
6. A 50-cent coin is tossed into the air.



What is/are the force(s) acting on the coin when it is up in the air?

- A Frictional force
- B Magnetic force
- C Gravitational force
- D Elastic spring force

- (1) C only
- (2) A and C only
- (3) B and D only
- (4) A, B and C only

7. The chart below shows the life cycle of a flowering plant.

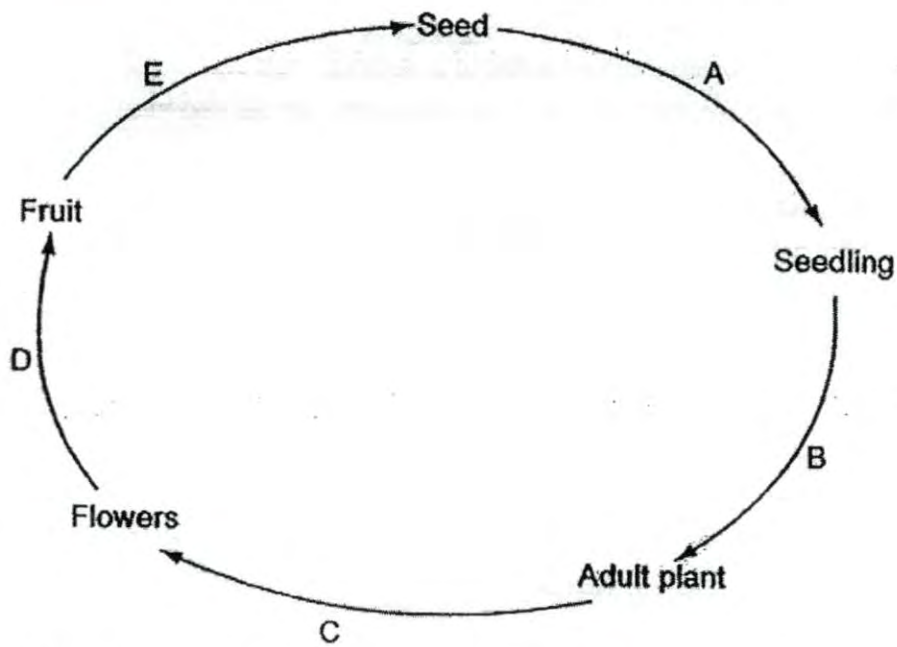

Which letters, A, B, C, D and E, represent fertilisation and germination?

	Fertilisation	Germination
(1)	A	B
(2)	B	C
(3)	C	E
(4)	D	A

8. Which of the following are reproductive organs of humans?

- A Egg
- B Sperm
- C Testes
- D Ovaries

- (1) A and C only
- (2) B and C only
- (3) B and D only
- (4) C and D only

9. Jenny, Clara, Peter and John each received a slide from their teacher to observe with a microscope. They recorded the parts of the cells observed in the following table:

	Parts of cells
Jenny	Cytoplasm, nucleus, cell membrane
Clara	Cytoplasm, cell wall, nucleus, cell membrane
Peter	Cytoplasm, cell wall, chloroplasts, nucleus, cell membrane
John	Cytoplasm, cell membrane

Which pupil(s) could have observed plant cells?

- (1) Peter only
 - (2) Clara and John only
 - (3) Clara and Peter only
 - (4) Jenny and John only
10. Which of the following cannot be used to connect X and Y to make the motor turn the fan blade?

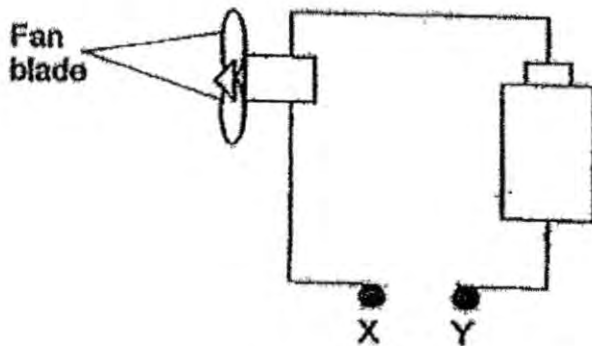

- A Magnet
 - B Paper clip
 - C Pencil lead
 - D Drinking straw
- (1) D only
 - (2) A and B only
 - (3) C and D only
 - (4) A, C and D only

11. Derrick put a leaf he had just plucked into a beaker of warm water as shown below. He noticed bubbles coming out of the leaf.

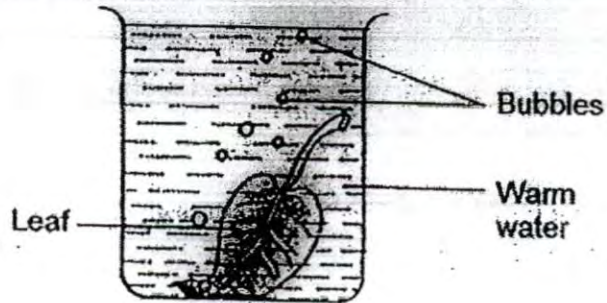

He noticed more bubbles on the underside of the leaf. Based on his observations, which one of the following statements can be inferred?

- (1) The leaf is taking in oxygen.
- (2) There are more stomata on the underside of the leaf.
- (3) A layer of wax was placed on the underside of the leaf.
- (4) The leaf is taking in water through the underside of the leaf.

12. A rock was placed at Point P. It rolled down a slope. Which one of the following graphs shows the correct change in gravitational potential energy and kinetic energy of the rock as it rolls to point Q?

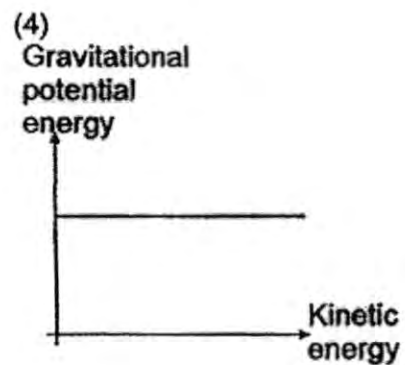
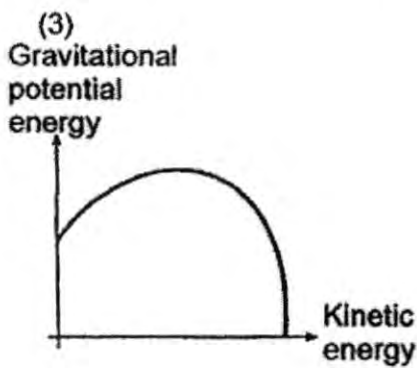
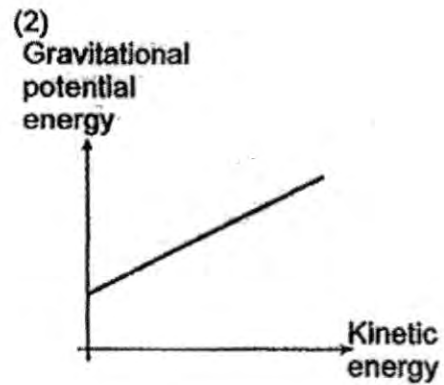
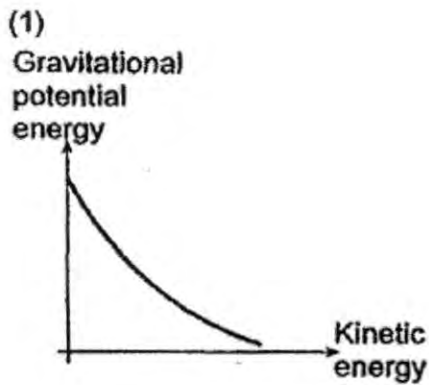
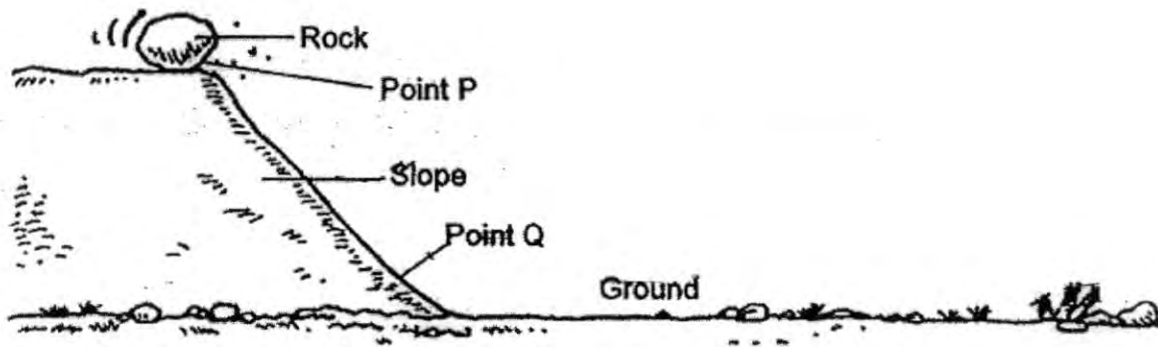

13. Kent placed a magnet at the top of the ramp, as shown in the diagram. The paper clip moved up the ramp and became attracted to the magnet.

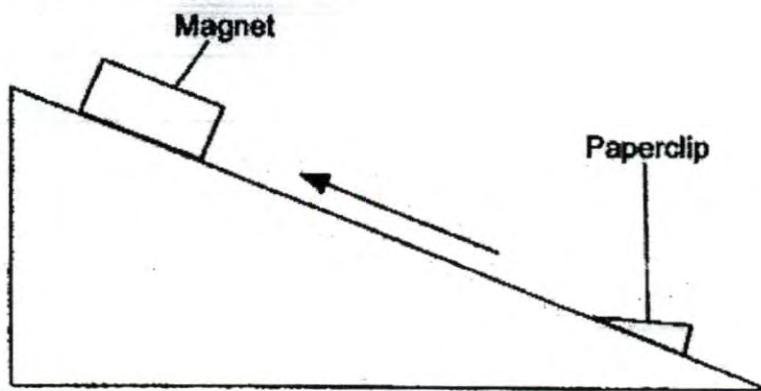

What is/are the force(s) acting on the paper clip as it moved up the ramp?

- A Frictional force
- B Magnetic force
- C Gravitational force
- D Elastic spring force

- (1) B only
- (2) A and C only
- (3) A, B and C only
- (4) A, B, C and D

14. Penny squeezed four identical tubes of facial cream from the same height above four identical plates as shown below. The amount of facial cream in each tube was the same in the beginning.

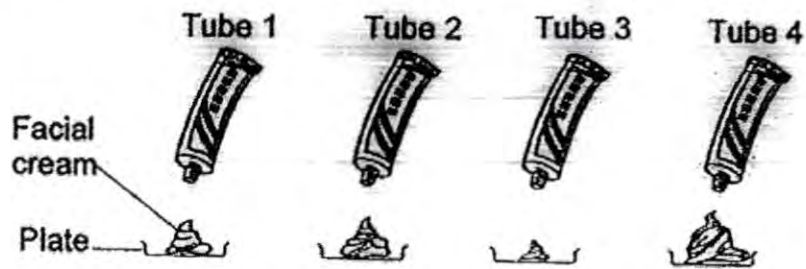

If Penny squeezed each tube only once, which of the following statements are true?

- A Different amount of forces were applied on the each tube.
- B More gravity acted on Tube 1 compared to Tube 4 at the end.
- C There was less facial cream left in Tube 2 compared to Tube 3.
- D In the end, Tube 4 has the most gravitational potential energy while Tube 3 has the least gravitational potential energy.

- (1) A and C only
- (2) B and C only
- (3) B and D only
- (4) A, B and C only

15. Kenny wants to find out if the height of a ramp affects the distance a matchbox is moved by a dry cell rolling down the ramp.

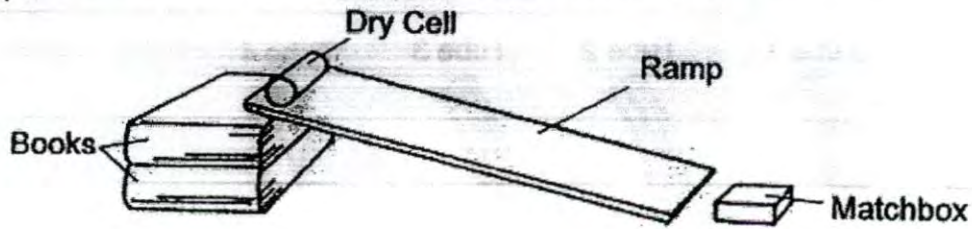

He conducted the experiment a few times. What is/are the condition(s) that Kenny must keep the same in order to ensure a fair test?

- A Size of dry cell
- B Mass of matchbox
- C Type of surface of ramp
- D Number of identical books

- (1) D only
- (2) B and C only
- (3) A, B and C only
- (4) A, B, C and D

16. Alvin conducted an experiment using Spring X. He hung 10g load from X and measured the increase in the length of X. He repeated the experiment by adding 10g load, one at a time, until the total load was 50g.

Next, Alvin started to remove a 10g load, one at a time, until there was no more load left. The graph below shows his results.

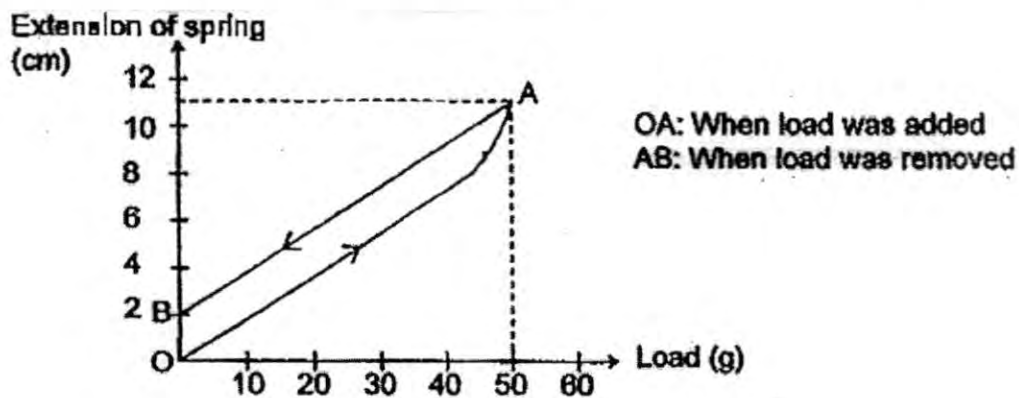

If the original length of the spring is 7cm, what is the length of the spring when there was no more load left?

- (1) 2cm
- (2) 7cm
- (3) 9cm
- (4) 18cm

- (1) A and B only
- (2) B and D only
- (3) A, C and D only
- (4) A, B, C and D

A The heart beats faster during exercise.
 B More oxygen is needed so we breathe faster during exercise.
 C Blood reaches different parts of the body faster when we exercise.
 D During exercise, we exhale faster, as a result carbon dioxide is given out faster.

Based on the given information above, which of the following statements are correct?

	Before exercise	During exercise
Pulse rate (Number of beats per minute)	71	105
Breathing rate (Number of breaths per minute)	35	52

18. Study the table below.

- (1) A and C only
- (2) A, B and D only
- (3) B, C and D only
- (4) A, B, C and D

A Water
 B Space
 C Sunlight
 D Nutrients

Which of the following do the plant need to compete with the weeds?

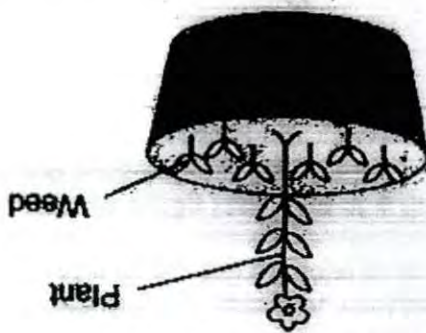

17. The plant in the diagram is surrounded by weeds.

19. The table below shows a comparison between the plant and human transport system.

Which one of the following comparisons about the plant and human transport system is correct?

	Plant transport system	Human transport system
(1)	Has only food carrying tubes to transport materials	Has only blood vessels to transport materials
(2)	Needs leaves and stem to pump materials to all parts of the plant	Needs a heart to pump materials to all parts of the body
(3)	Transport food that is made by the leaves	Transport food that has been digested by the digestive system
(4)	Transports only food and water	Transports only food, water and oxygen

20. Look at the diagram below.

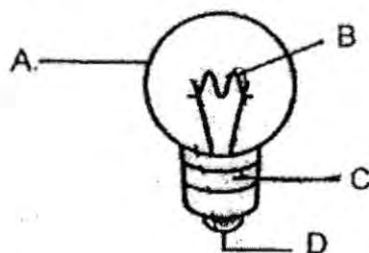

Which parts of the bulb conduct electricity?

- (1) A and D only
- (2) B and C only
- (3) B, C and D only
- (4) A, B, C and D

21. The light bulbs shown in the diagram below are connected in series.

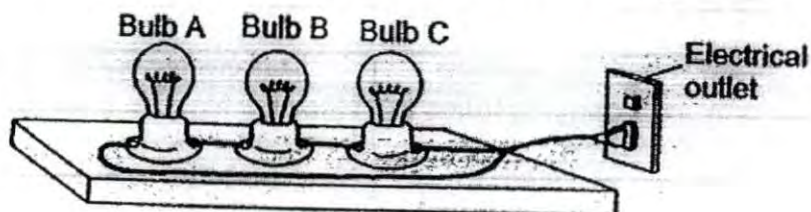

Suppose one of the bulbs is blown, what could you do to determine which bulb is blown?

- (1) Turn on the switch in the electrical outlet and observe which bulb does not light up.
 - (2) There is no way to determine which bulb is blown when they are connected in series.
 - (3) Reconnect all the three bulbs in parallel arrangement and turn on the switch in the electrical outlet.
 - (4) Turn on the switch in the electrical outlet and remove one bulb at a time until the other two bulbs light up.
22. James placed a test tube of water into a beaker of ice as shown in the diagram below. He then left the set-up in the Science Room.

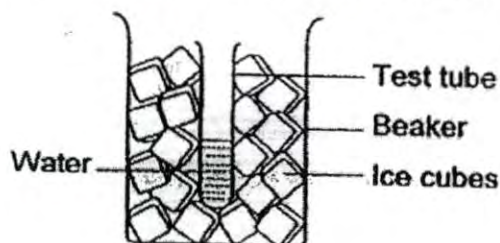

Which of the following statements are true after 5 minutes?

- A The mass of the set-up increases.
 - B The mass of the set-up decreases.
 - C The temperature of the water in the test tube increases.
 - D The temperature of the water in the test tube decreases.
- (1) A and C only
 - (2) A and D only
 - (3) B and C only
 - (4) B and D only

23. Study the water cycle below.

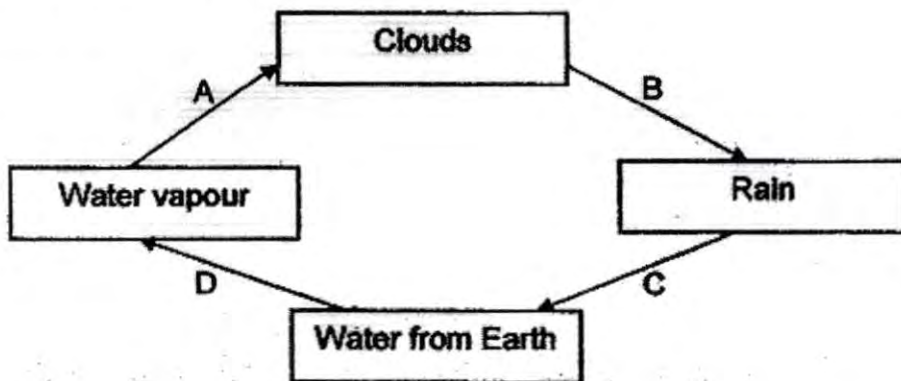

Which of the following shows that heat loss and heat gain had taken place in the water cycle?

	Heat loss	Heat gain
(1)	A	D
(2)	B	A
(3)	C	B
(4)	D	C

24. Melvin cut out a circle from a clear plastic sheet and a square from a sheet of metal as shown below.

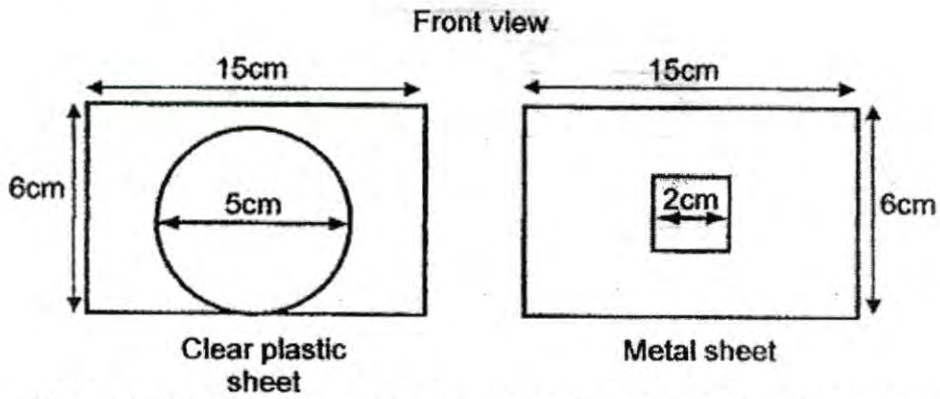

Then the two remaining rectangular sheets are glued together and placed between a torch and a screen in a dark room as shown below.

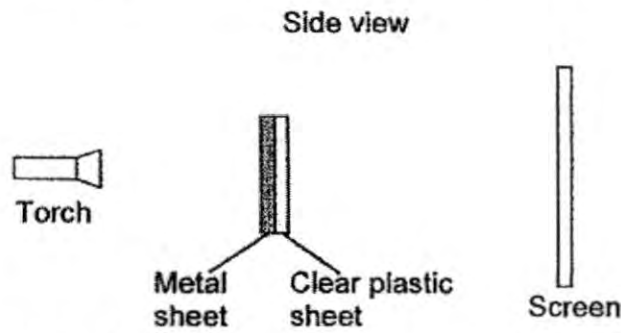

Which of the following could be the shadow cast on the screen?

(1)



(2)



(3)

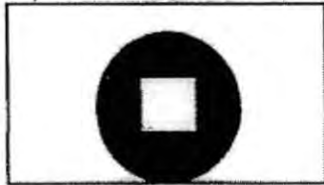

(4)



25. A piece of paper with a steel ring attached to it was placed over a flame for 30 seconds as shown below.

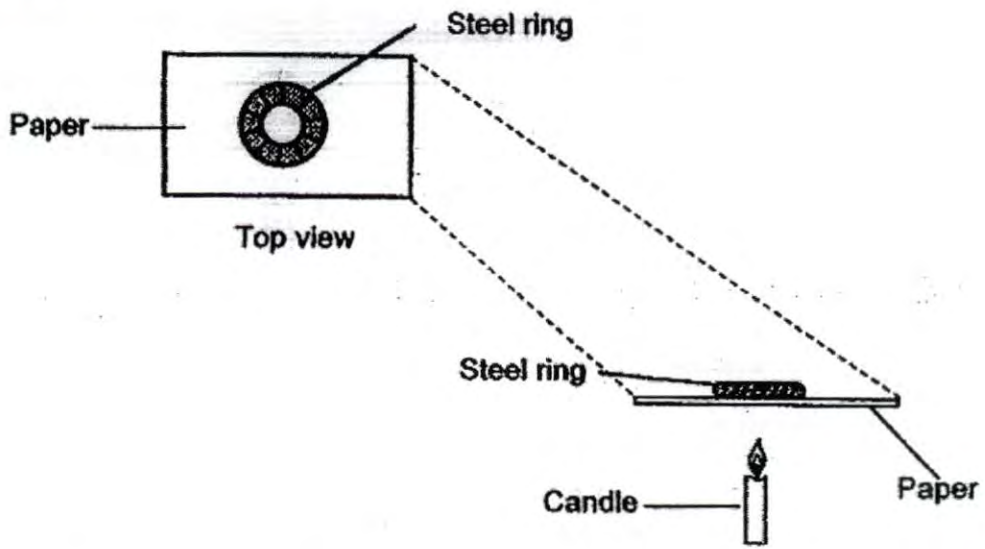

When the flame was removed, there was a scorched surface on the paper. Which of the following shows the most likely effect of the heat on the paper?

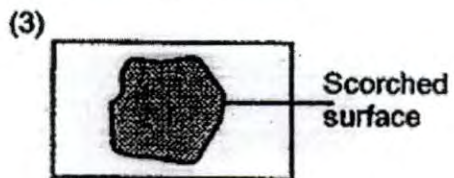
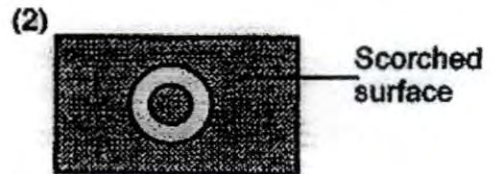

26. Diagram X shows a stage in the life cycle of a butterfly. Diagram Y shows a stage in the life cycle of a mosquito.

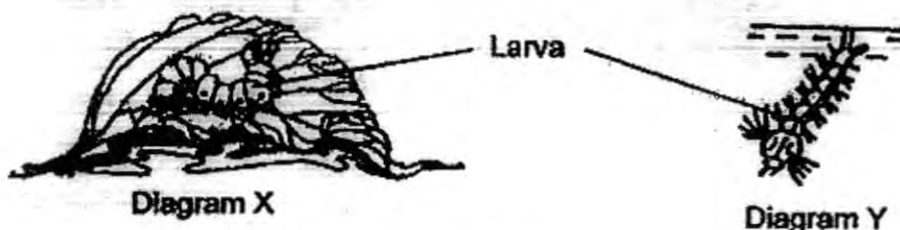

In what ways are the two stages similar?

- A They live in water.
- B They hatch from eggs.
- C They undergo moulting.
- D They are wingless, so they cannot move about by themselves. λ

- (1) B and C only
- (2) C and D only
- (3) A, B and C only
- (4) A, B and D only

27. The table below shows the freezing points and boiling points of three unknown substances, P, Q and R.

Substance	Freezing point ($^{\circ}\text{C}$)	Boiling point ($^{\circ}\text{C}$)
P	15	103
Q	27	45
R	105	210

Which of the following substances, P, Q and R, is/are gas(es) at 100°C ?

- (1) Q only
- (2) P and Q only
- (3) P and R only
- (4) P, Q and R

28. Study the following groups of objects.

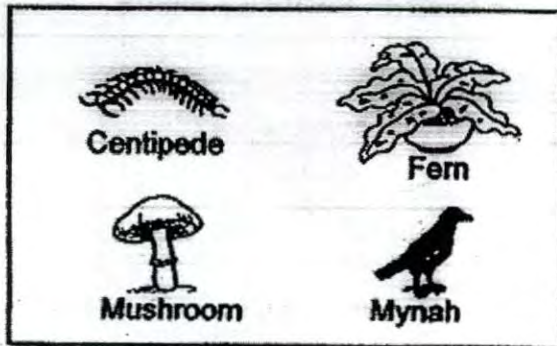

Group S

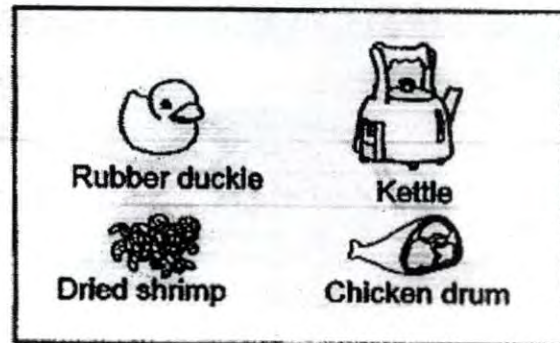

Group T

How are the objects in Group S different from the objects in Group T?

	Group S	Group T
A	Alive	Once alive
B	Move from place to place by themselves	Cannot move from place to place by themselves
C	Respond to changes	Cannot respond to changes
D	Can reproduce	Cannot reproduce

- (1) A and B only
- (2) C and D only
- (3) A, B and C only
- (4) B, C and D only

29. Study the chart below.

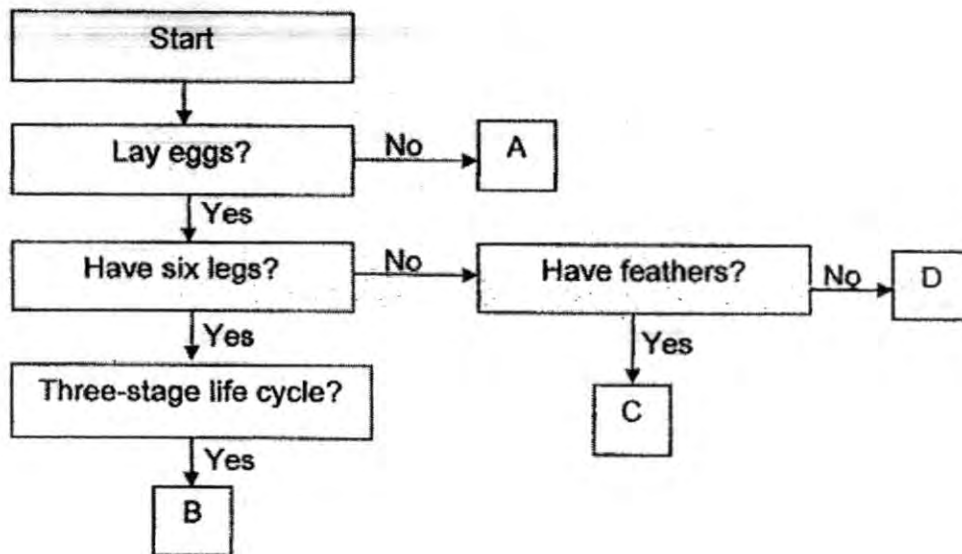

Which of the following can Animals, A, B, C and D be?

	A	B	C	D
(1)	Goat	Butterfly	Eagle	Ladybird
(2)	Mouse	Cockroach	Kingfisher	Squirrel
(3)	Platypus	Housefly	Woodpecker	Bat
(4)	Whale	Grasshopper	Penguin	Spiny anteater

30. The diagram below shows four types of string, P, Q, R and S. It also shows the maximum mass that each string can support without breaking.

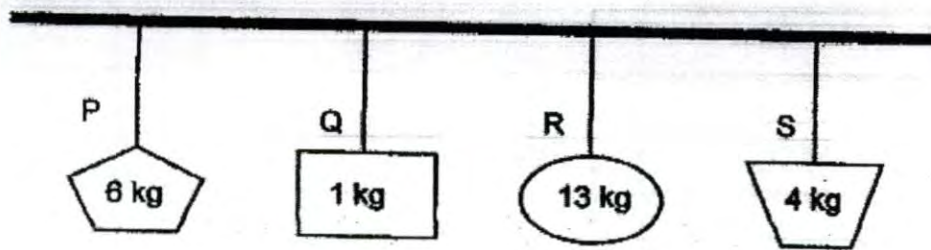

In which one of the following set-ups will all the strings remain unbroken?

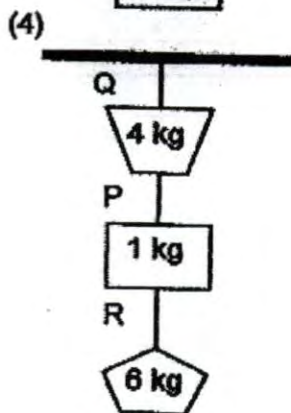
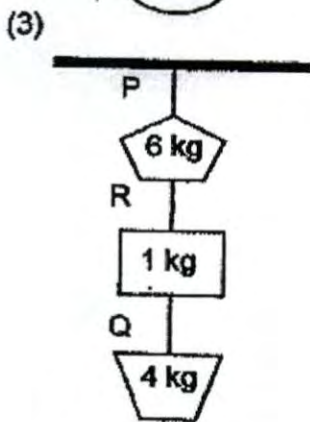
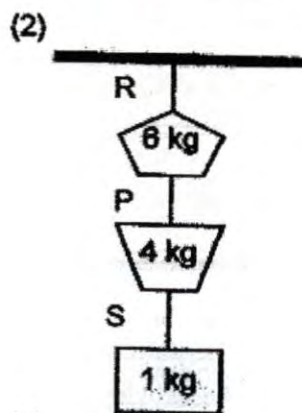
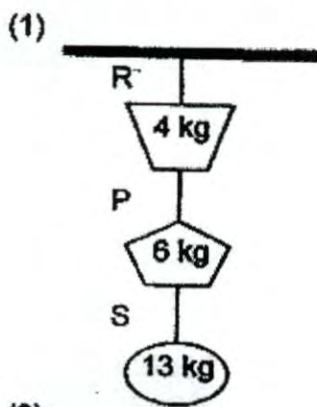

End of Section A



NAN HUA PRIMARY SCHOOL
CONTINUAL ASSESSMENT 1 2015
PRIMARY SIX
SCIENCE

Name : _____ ()

Class : Primary 6 / _____

MARKS
40

Section B: (40marks)

Write your answers to question 31 to 44.

The number of marks available is shown in brackets [] at the end of each question or part question.

31. Megan dropped a ball from a table. The path it took is represented by the dotted lines in the diagram below.

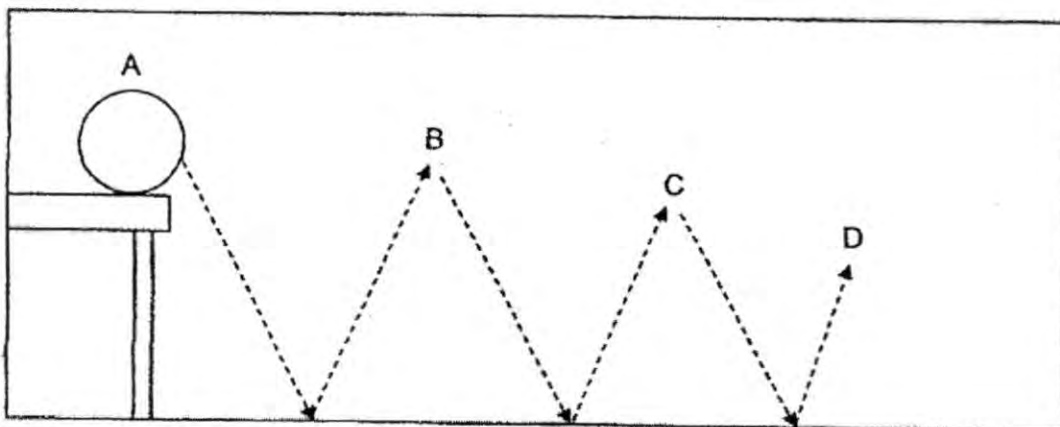

Megan repeated the experiment three times and recorded the bouncing height of the ball, B, C and D, in the table below.

Number of tries	Height (cm)		
	B	C	D
1 st	76	60	39
2 nd	78	61	40
3 rd	77	62	41
Average height	77	61	40

- (a) At which position, A, B, C or D, did the ball have the greatest gravitational potential energy? [1]

Score	1
-------	---

(b) Give a reason for your answer in part (a).

[1]

(c) Why did the ball not bounce back to the original height?

[1]

Score	2
-------	---

32. Tommy bought three springs of different materials but of the same length and thickness for an experiment.



He compressed each spring and then released it. He measured the greatest height reached by the spring for each attempt and recorded the readings in the table below.

Spring	Height reached by the spring when released (cm)			
	1 st attempt	2 nd attempt	3 rd attempt	Average
X	9.3	8.4	9.0	8.9
Y	11.7	10.5	10.3	10.8
Z	7.3	6.7	8.0	7.3

- (a) What form of energy did the compressed spring possess? [1]

- (b) For each spring, the greatest height it reached was different for every attempt. Give one possible reason for this. [1]

33. Wendy threw a toy parachute from the 4th storey of her school. Within seconds, the toy fell to the ground.

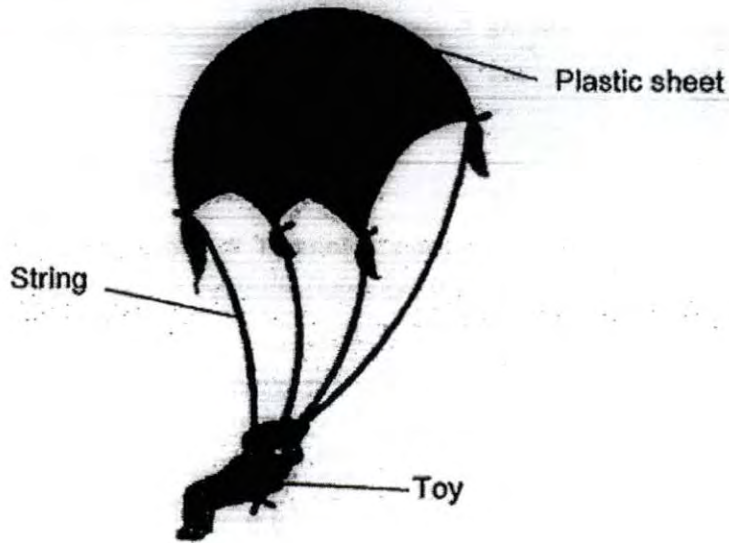

- (a) What was/were the force(s) acting on the toy? [1]

- (b) Her teacher told Wendy that by using a smaller plastic sheet, the toy parachute will fall to the ground faster. Give a reason for this. [1]

Score	2
-------	---

34. Joseph tossed a ball into the air and then gave it a hard kick. After the ball was given a hard kick, it moved faster than it was tossed in the air. The diagram below shows the path of the ball after he kicked it.

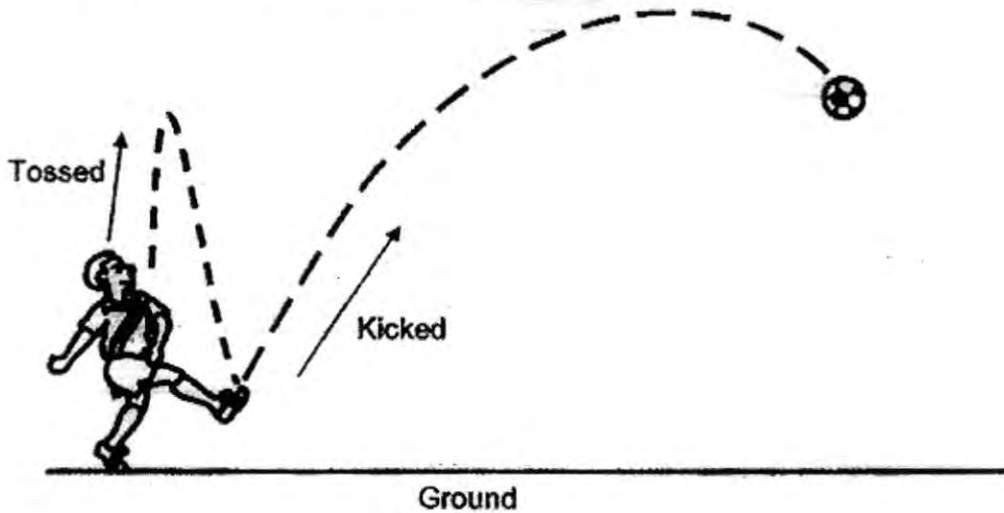

- (a) Name two effects of forces shown when he kicked the ball. [2]

- (b) The diagram shows the path taken by a ball when Joseph kicked it. Then Joseph changed to a lighter ball and kicked the lighter ball with the same force and in the same direction. Draw the path of the lighter ball on the diagram below using Y as the starting point again. [1]

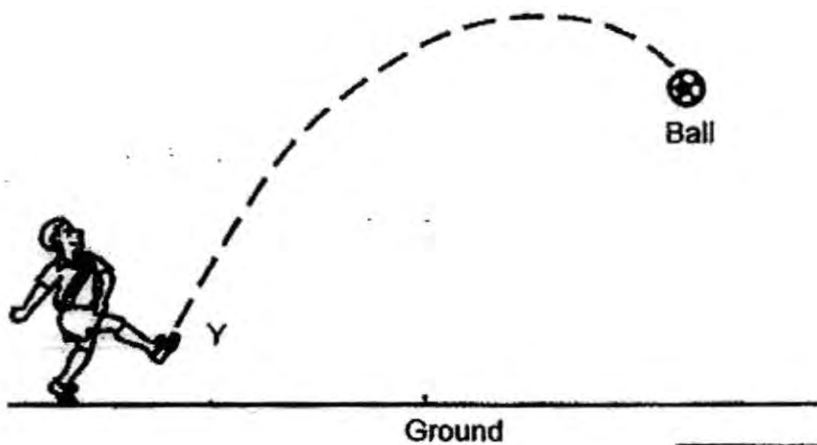

26

Score	3
-------	---

35. At our lungs, there are many air sacs. The diagram below shows the exchange of gases in the air sac.

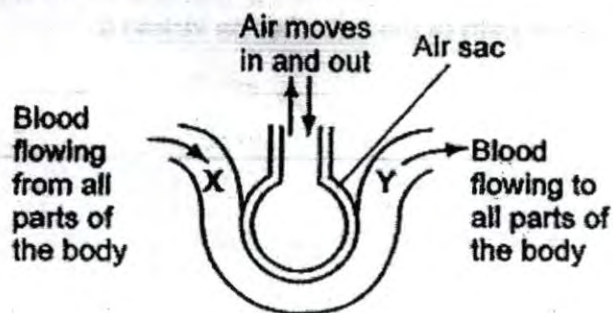

- (a) Write down one difference between the blood at X and the blood at Y. [1]

When a person smokes regularly, the air sac is blocked with the residue of the cigarette as shown in the diagram.

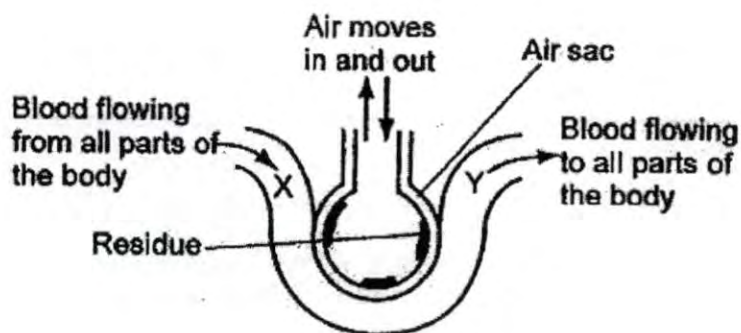

- (b) Why does a smoker require to take more breaths than a healthy person who does not smoke? [2]

36. Brandon set up an experiment as shown below to show that carbon dioxide is necessary for photosynthesis. He enclosed two large leaves in two similar flasks. The plant was left under the sun for a few days.

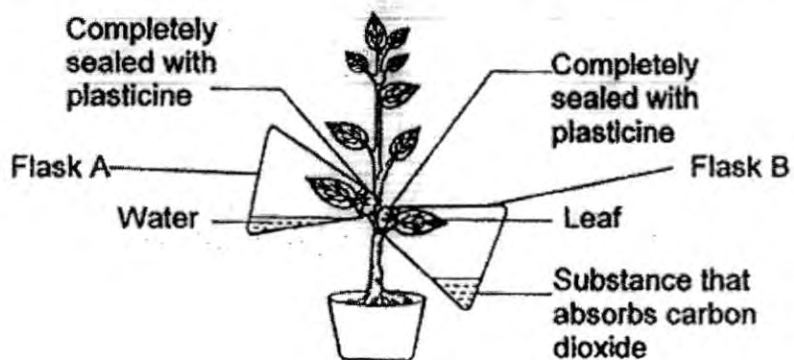

- (a) Why must the flasks be sealed? [2]

- (b) Why did Brandon need to have to have Flask B in the experiment? [1]

Score	3
-------	---

37. Study the set-up below.

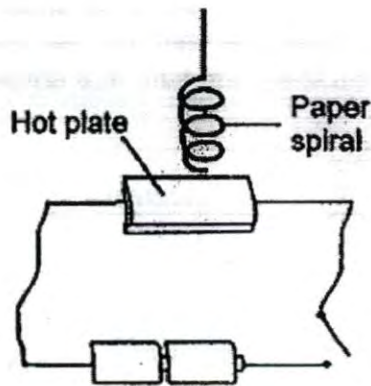

(a) In the above experiment, what must be done so that the paper spiral can spin. Give a reason for your answer. [1]

(b) Explain why the paper spiral spin? [2]

(c) What was the energy change that took place? Fill in each blank with the correct form of energy. [1]



Score	4
-------	---

38. The key of a wound-up toy was turned different number of times and the distance it moved was recorded in the table below.



Number of times the key was turned	2	4	6	8	10
Distance moved (cm)	5	10	15	20	25

- (a) What is the relationship between the number of times the key was turned and the distance moved by the toy? [1]

- (b) Plot a line graph based on the data shown in the table above. Fill in the boxes with the correct axis title. [2]

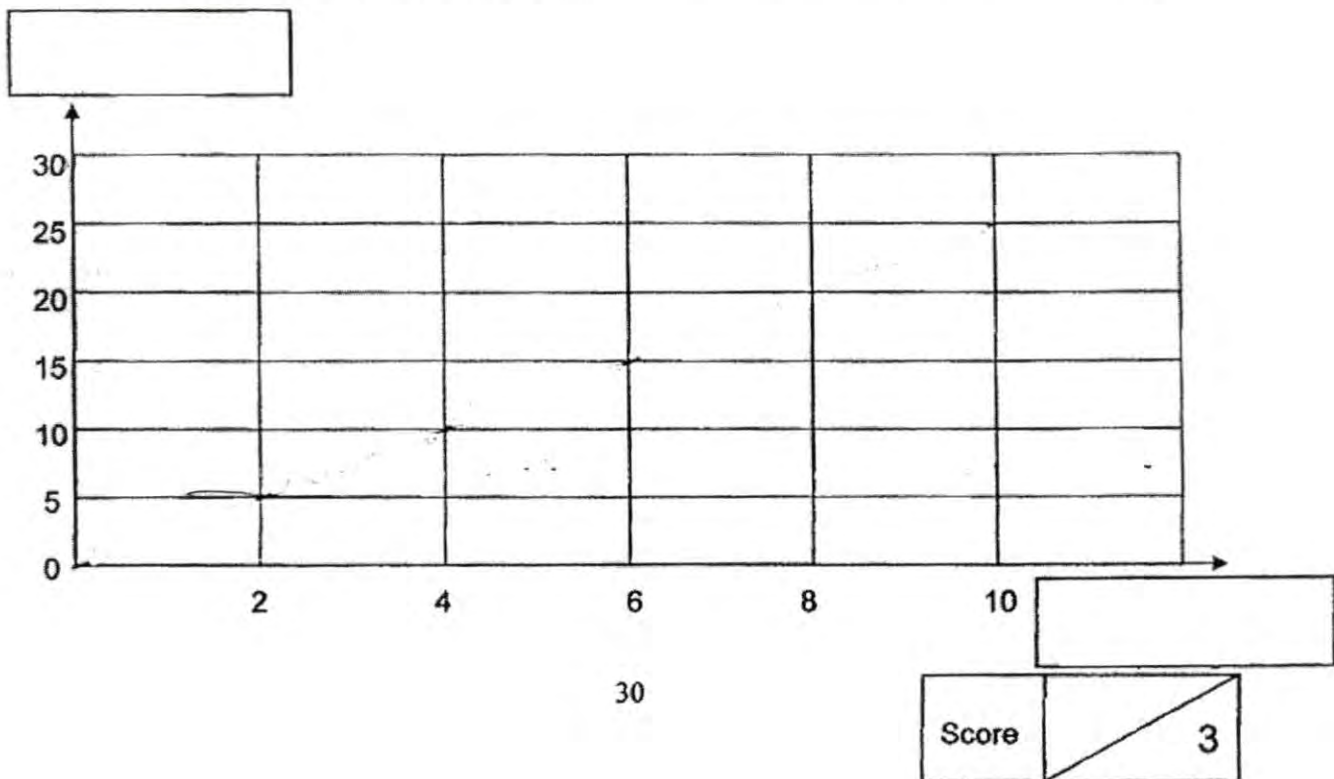

2	Score
---	-------

What will happen to the ping pong ball when Raneer brings Magnet P closer to Magnet Q? Explain your answer. [2]

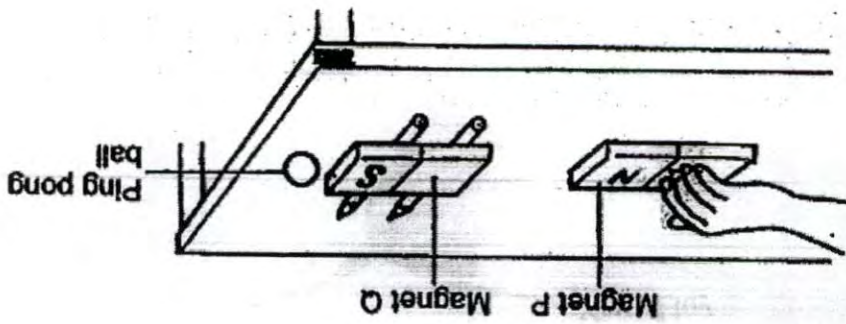

39. Raneer set up the experiment as shown below.

40. Brenda could pick up a dry glass cup without the cup slipping from her hand. After she applied some hand cream on her hands and tried to pick up the same glass cup, it slipped through her fingers.

(a) Explain why the glass cup slipped from her fingers. [1]

Brenda was walking into a school toilet and found a sign placed at the toilet. The sign warned her that she might slip when walking on the wet floor.



(b) Explain why Brenda might slip when walking on the wet floor. [2]

Score	3
-------	---

41. Alvin attached four objects of different mass to identical springs as shown in the diagram below.

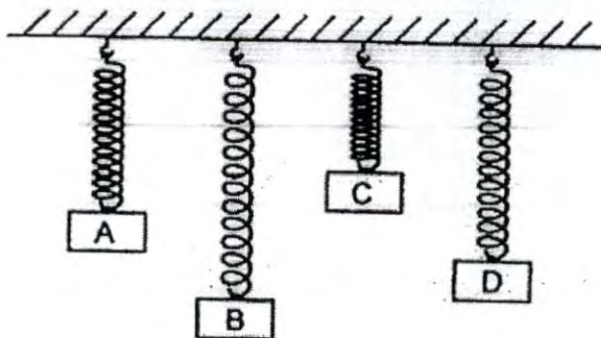

- (a) Arrange the four objects in descending order of their mass. [1]

- (b) What is the relationship between the mass of the object and the extension of the spring? [1]

- (c) Alvin removed the objects from all the springs and observed that the spring in which object B was attached to was longer than the other springs. Give a reason for the observation. [1]

42. The diagram below shows three identical bulbs that Mr Tan puts inside a dollhouse that is powered by a dry cell.

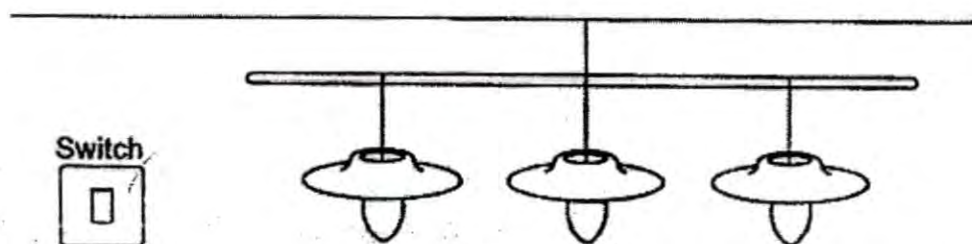

All the three bulbs light up when the switch is turned on. They have the same brightness. However, when one bulb fuses, the other two bulbs remain lit.

- (a) Construct a circuit diagram in the box below to show how the bulbs are connected. [2]

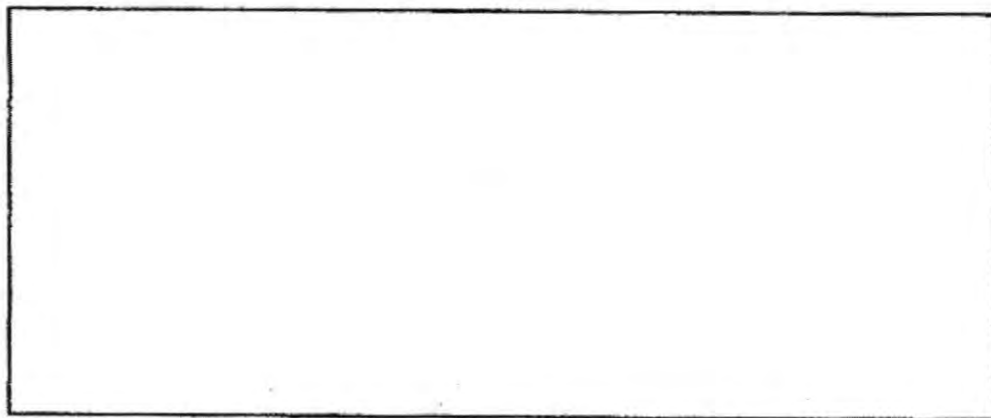

- (b) The light from the bulbs are too bright. Without adding objects to the circuit, suggest one way to reduce the brightness by changing the arrangement of the bulbs. [1]

43. Study the set-up below.



When the torch was shone on the object, a dark shadow of the object was cast on the screen.

- (a) What would happen to the shadow if the object was shifted nearer to the source of light? [1]

A few cardboards with holes cut in each of them are placed between the object and the torch as shown below.

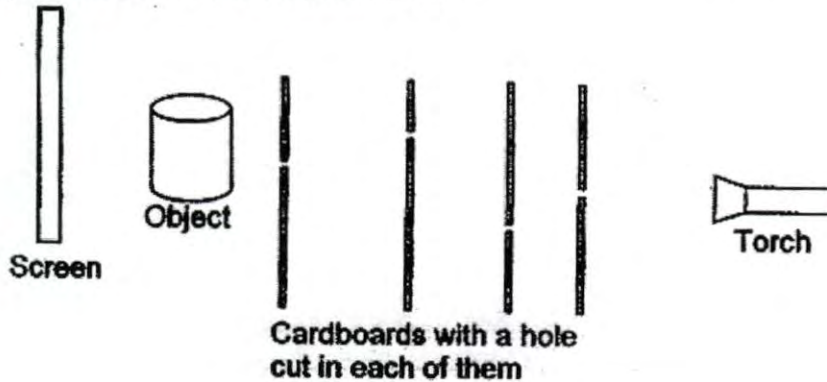

- (b) Will the shadow of the object be cast on the screen when the light is shone on the cardboards? Explain your answer. [2]

Score	3
-------	---

44. Germaine blew the same amount of air into two balloons, one made from Material X and the other from Material Y. Both balloons inflated to the same size. Then she tied the balloons at the window grill in his living room as shown below.

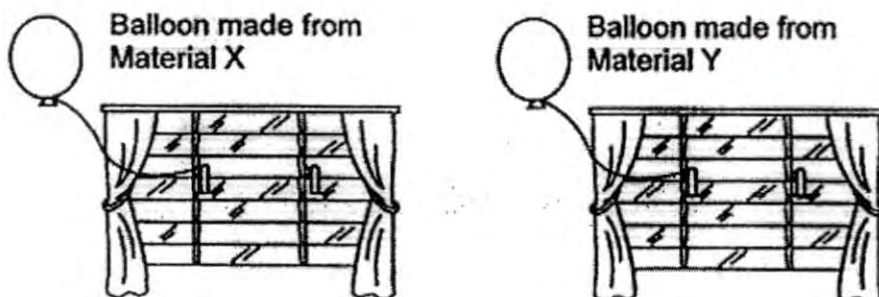

At noon, she observed both the balloons and recorded her observations in a table.

	Observations
Balloon made from Material X	<ul style="list-style-type: none"> • Became bigger • Burst
Balloon made from Material Y	<ul style="list-style-type: none"> • Became bigger but not as big as the balloon made from Material X • Did not burst

- (a) Explain why both balloons became bigger in size at noon but not in the morning. [2]

- (b) Give a reason why the balloon made from Material X became bigger than the balloon made from Material Y. [1]

Score	3
-------	---

EXAM PAPER 2015

SCHOOL : NAN HUA

SUBJECT : P6 SCIENCE

TERM : CA1

Q1	Q2	Q3	Q4	Q5	Q6	Q7	Q8	Q9	Q10
4	4	2	4	3	2	4	4	3	1
Q11	Q12	Q13	Q14	Q15	Q16	Q17	Q18	Q19	Q20
2	1	3	1	3	3	2	4	3	3
Q21	Q22	Q23	Q24	Q25	Q26	Q27	Q28	Q29	Q30
3	2	1	2	4	1	1	2	4	2

31)a)A.

b)The distance between A and the ground is the greatest compared to B,C and D.

c)Some of its kinetic energy had been converted to other forms of energy like heat and sound energy.

32)a)Elastic potential energy.

b)The springs were compressed with a different amount of force each time.

33)a)Gravity and air resistance.

b)The plastic sheet will have a smaller surface area in contact with air so it will counter less air resistance.

34)a)The ball changed direction and moved at a greater speed.

b)

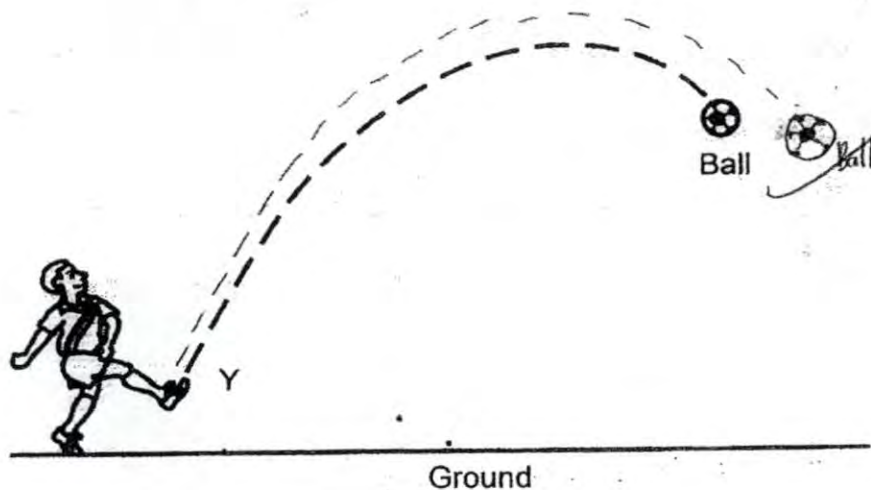

35)a)The Blood of X contained more carbon dioxide but less oxygen as compared to the blood at Y.

b)The air sac is now blocked with residues and there will be less surface area to allow gaseous exchange to occur.

36)a)This is to ensure that carbon dioxide from the surrounding air cannot enter the flasks. This will ensure that only Flask A has carbon dioxide and Flask B will not have any carbon dioxide.

b)Flask B is the experiment set up used to show that carbon dioxide is needed for photosynthesis as there is no carbon dioxide in Flask B.

37)a)The switch must be closed, so that the circuit is closed and electricity can flow through the circuit.

b)When the switch is closed, electricity will flow through the circuit and the electricity energy will be converted to heat energy. The heat energy will heat up the hot plate. The heat from the hot plate would be lost to the surrounding air and the hot air will rise. As the hot air rises, it pushes the paper spiral thus causing the paper spiral to spin.

c)Chemical Potential Energy → Electrical Energy → Heat Energy → Kinetic energy → Kinetic Energy

38)a)As the number of times the key was turned increases, the distance moved by the toy also increases.

b)

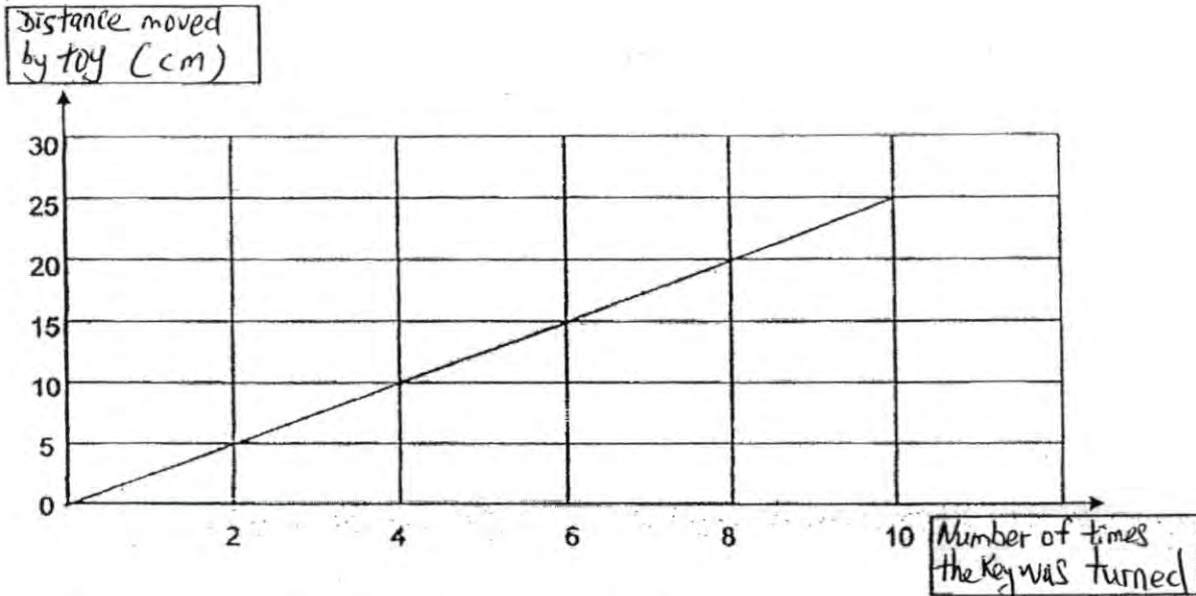

39)The ping pong ball will drop from the table to the ground. Magnet P and magnet Q have like poles facing each other. When the like-poles of magnet P and Q were brought to each other, they would repel. Magnet Q would move backwards as there are roller under heath it and the Magnet will hit the ping pong ball causing it to full to the ground.

40)a)As a result the weight of the glass cup is greater than the friction force between her fingers and the glass cup.

b)The water acted a lubricant so it will reduce the friction between Brenda's feet and the ground making her slip.

41)a)B,D,A,C

b)As the mass of the object increases, the extension of the spring also increases.

c)The spring was over stretched and could not return to its original length.

42)a)

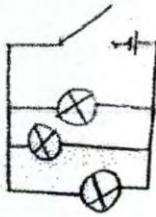

b)Change the arrangement of bulbs from parallel to series.

43)a)The shadow would be bigger.

b)No. Light travels in straight lines. The light would not be able to were through the holes as the holes as the hole are not aligned in a straight.

44)a)It was warmer at noon in the morning. The air in the balloon gain heat from the surroundings and expanded.

b)Material X is more stretch able and the expanded air was not compressed as much in the balloon.