



## PRIMARY 5 END-OF-YEAR EXAMINATION 2015

Name: \_\_\_\_\_ ( )

Date: 30 October 2015

Class: Primary 5 ( )

Time: 8.00 a.m. to 9.25 a.m.

Duration: 1h 25min

Booklet A marks: \_\_\_\_\_ / 50

Parent's Signature: \_\_\_\_\_

Total marks: \_\_\_\_\_ / 80

# SCIENCE BOOKLET A

### INSTRUCTIONS TO CANDIDATES

Write your name, register number and class.

Do not turn over this page until you are told to do so.

Follow all instructions carefully.

Answer all questions.

**Section A (25 × 2 marks = 50 marks)**

For each question from 1 to 25, four options are given. One of them is the correct answer. Make your choice (1, 2, 3 or 4). Shade the correct oval (1, 2, 3 or 4) on the Optical Answer Sheet.

1. Which of the following is true about reproduction in plants?

- (1) The ovary produces the male reproductive cell.
- (2) The anther of a flower receives the pollen grains.
- (3) The stigma and the filament are the female parts of a flower.
- (4) The ovule develops into a seed after fertilisation has taken place.

2. Study the flow chart below. A, B, C and D represent four different fruits.

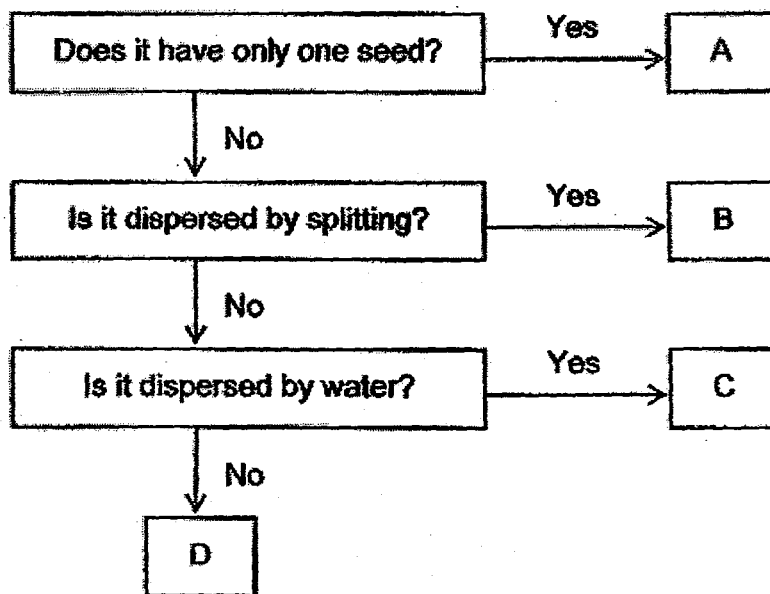

Which of the following is represented by A, B, C and D?

	A	B	C	D
(1)	Kiwi	Watermelon	Lotus	Papaya
(2)	Orange	Saga	Watermelon	Papaya
(3)	Mango	Saga	Lotus	Watermelon
(4)	Rambutan	Papaya	Coconut	Mango

3. Mary wanted to find out how the length of the wing-like structure of the fruit below affects the distance travelled by the fruit when dropped.



Which of the following variable(s) should Mary keep constant to ensure a fair test?

- A Mass of fruits
  - B Length of the wing-like structure
  - C Height from which the fruits were dropped
  - D Location where the experiment was carried out
- (1) B only  
(2) A and B only  
(3) C and D only  
(4) A, C and D only

4. The diagram below shows the female human reproductive system. At which part of the system does fertilisation take place?

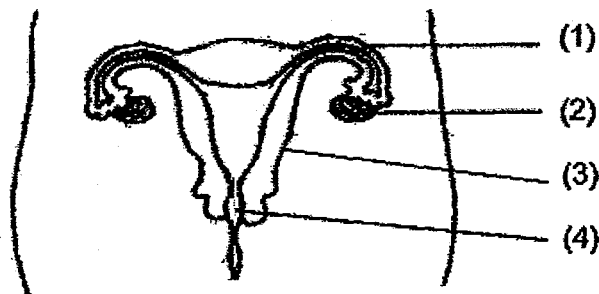

5. Which of the following traits can be passed on from parents to their young?

- (1) Blood type
- (2) Muscle size
- (3) Fingerprints
- (4) Length of nails

6. A, B, C, D, E and F represent processes that lead to the changes in state of water.

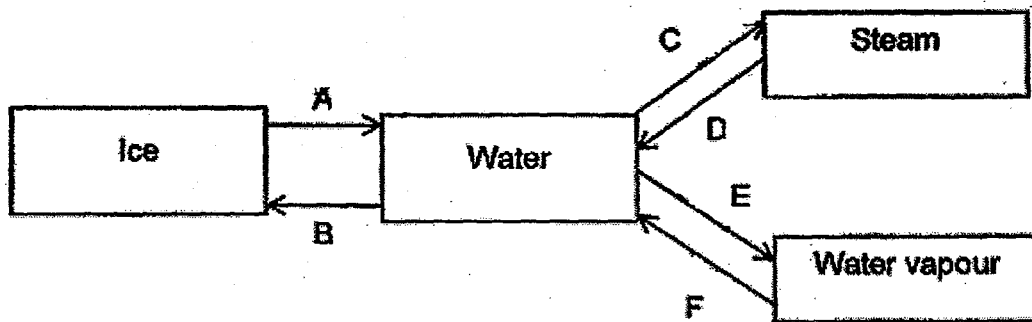

Which of the following processes, A, B, C, D, E and F, involve heat loss?

- (1) A, C and E
- (2) B, D and F
- (3) A, D and E
- (4) B, C and F

7. In an experiment, 3 identical beakers with identical covers were placed in a room at 30°C. Each beaker, A, B and C, contained water at different temperatures.

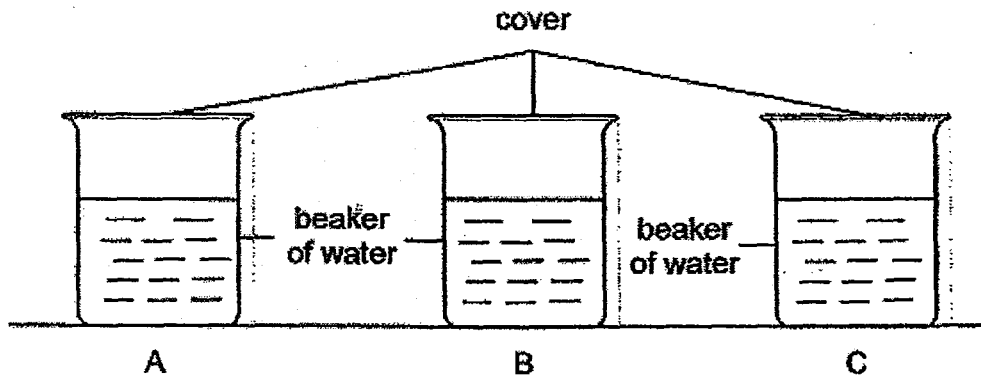

The diagram below shows what happened after some time.

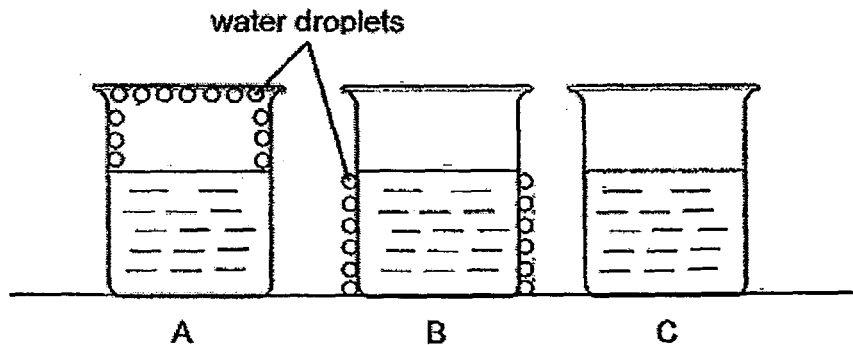

Which of the following shows the temperature of the water in each beaker at the start of the experiment?

	A	B	C
(1)	80°C	10°C	30°C
(2)	80°C	30°C	10°C
(3)	10°C	80°C	30°C
(4)	30°C	10°C	80°C

8. In an experiment, Ryan heated some cold water in a beaker using a gas burner. After 10 minutes, the water started to boil. He continued heating the water for another 10 minutes before turning off the gas burner.

Which of the following graphs shows the temperature change of the water in Ryan's experiment?

(1)

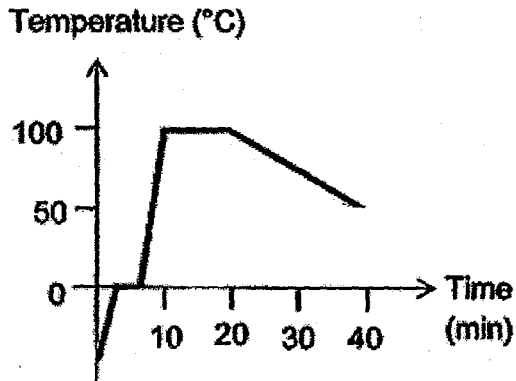

(2)

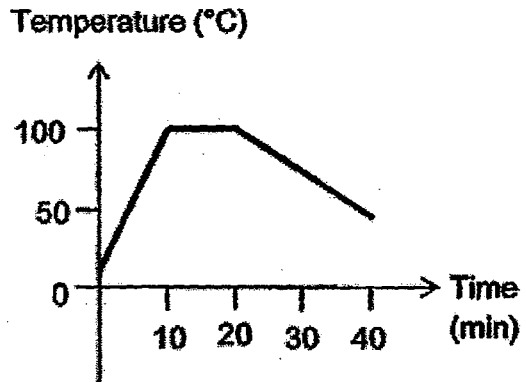

(3)

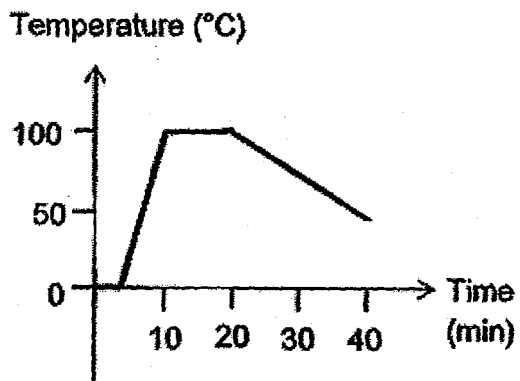

(4)

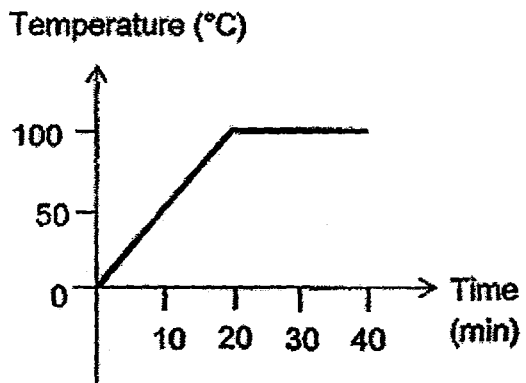

9. In the diagram below, A, B and C represent 3 different parts of the human body. The arrows show the flow of blood in the human body.

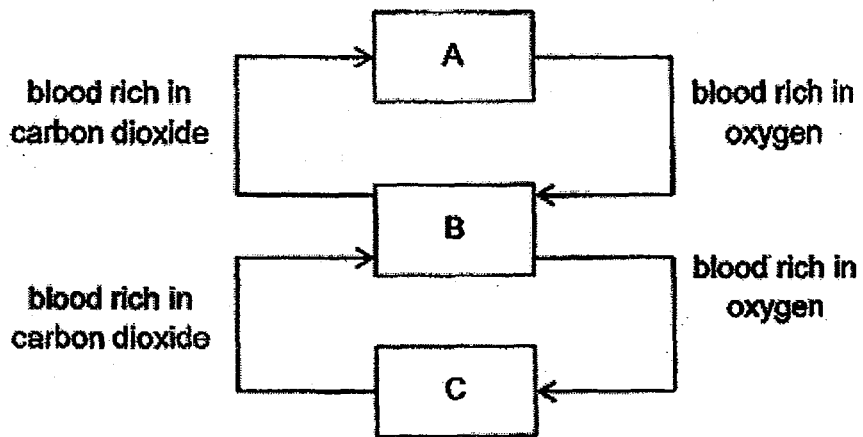

Which of the following are the body parts represented by A, B and C?

	A	B	C
(1)	Lungs	Heart	Head
(2)	Head	Heart	Lungs
(3)	Heart	Lungs	Head
(4)	Lungs	Head	Heart

10. Sam set up an experiment as shown below. He wrapped two similar leaves, A and B, of a plant with two different plastic bags. He wrapped A in a clear plastic bag and B in a black plastic bag. The plastic bags were of the same size and thickness. He left the plant under bright light for 5 hours.

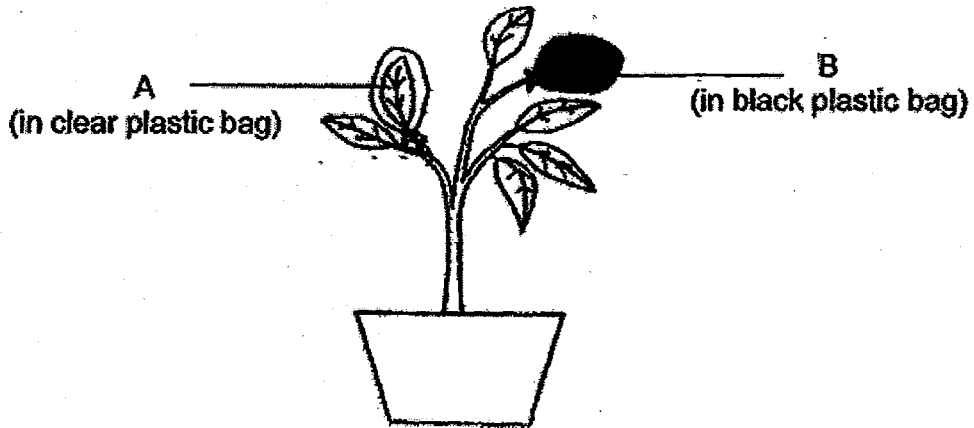

Which of the following graph represents the amount of carbon dioxide in the plastic bags after 5 hours?

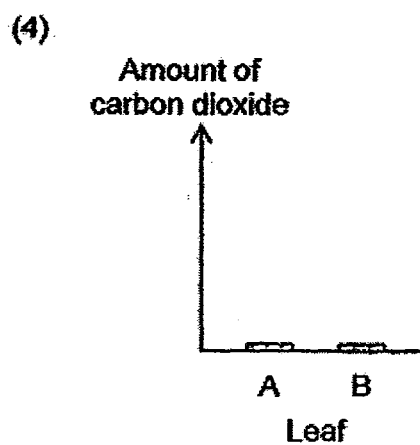
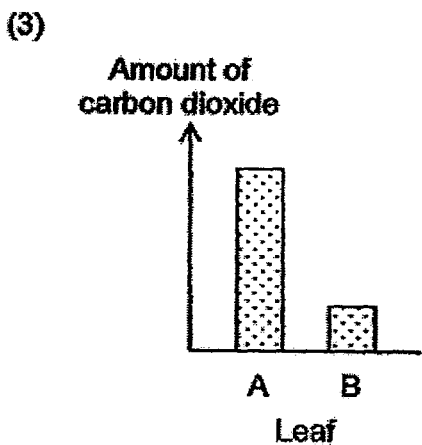
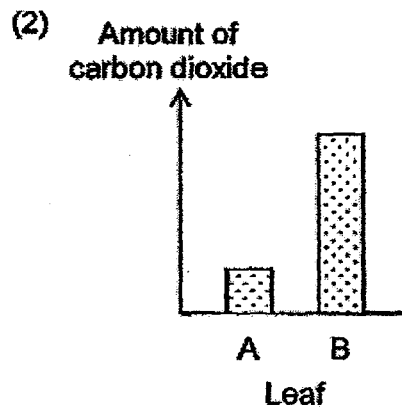
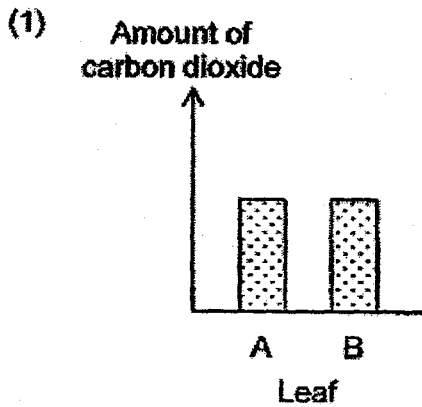



11. Lily removed the outer ring of a plant's stem at X as shown below.

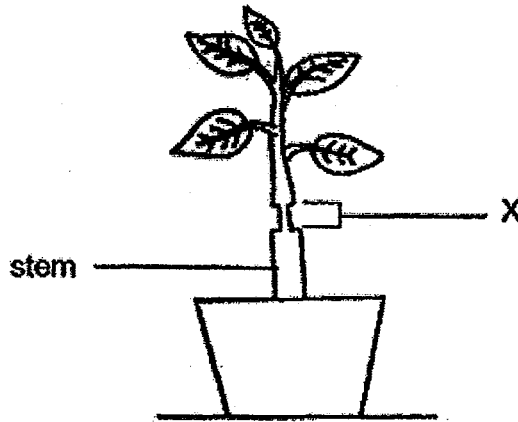

Lily left the plant under the Sun and watered it every day. After a few days, she observed that the plant was still alive and part of the stem above X was swollen as shown below.

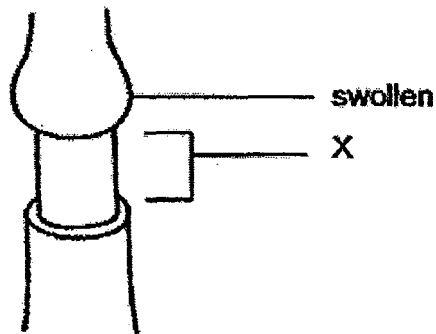

Which of the following explains why part of the stem above X was swollen?

- (1) Food cannot be transported to the part below X.
  - (2) Water cannot be transported to the part below X.
  - (3) Food cannot be transported to the part above X.
  - (4) Water cannot be transported to the part above X.
12. The nucleus of a plant cell requires Substance X. Which of the following shows the path of Substance X from the outside of the cell to the nucleus?
- (1) Cytoplasm → Cell membrane → Cell wall
  - (2) Cell membrane → Cell wall → Cytoplasm
  - (3) Cell wall → Cell membrane → Cytoplasm
  - (4) Cell wall → Cytoplasm → Cell membrane

13. Study the three different cells below.

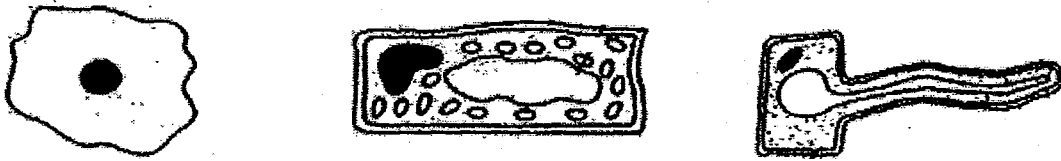

Which of the following statements is true of all the three cells?

- (1) They can make food.
- (2) They are animal cells.
- (3) They contain cytoplasm and cell wall.
- (4) They have nucleus and cell membrane.

14. The diagram below shows a life process that occurs in both plants and animals.

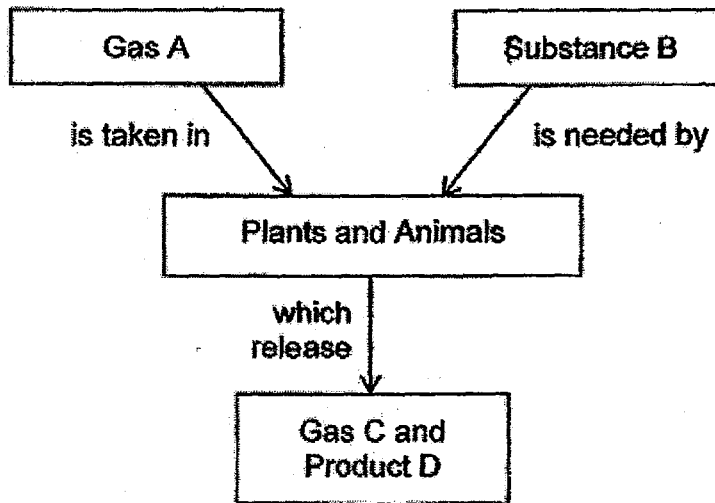

Which of the following are represented by Gas A, Substance B, Gas C, and Product D?

	Gas A	Substance B	Gas C	Product D
(1)	Carbon dioxide	Water	Oxygen	Starch
(2)	Oxygen	Food	Carbon dioxide	Energy
(3)	Carbon dioxide	Food	Oxygen	Energy
(4)	Oxygen	Water	Carbon dioxide	Starch

15. Bulbs B1, B2 and B3 and switches S1, S2 and S3 are connected in an electric circuit as shown below. All the parts of the circuit are in good working condition.

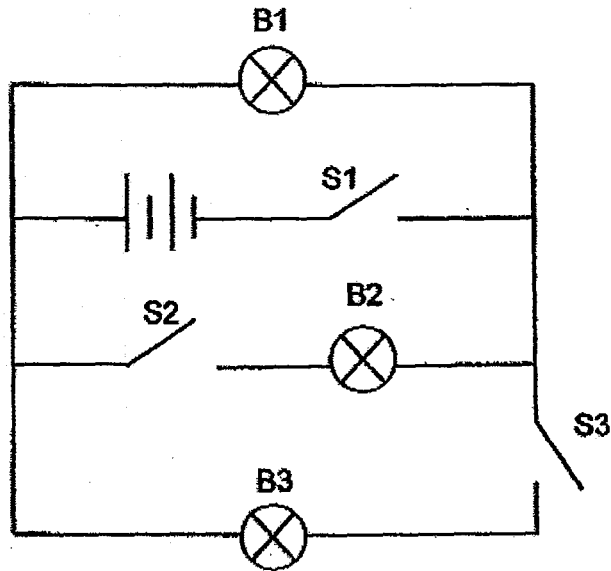

Which of the following is correct?

	Are the switches closed or open?			Do the bulbs light up?		
	S1	S2	S3	B1	B2	B3
(1)	closed	open	closed	yes	no	yes
(2)	open	open	closed	no	no	yes
(3)	open	closed	open	yes	yes	no
(4)	closed	closed	open	no	yes	no

16. Study the circuit diagram below. All the bulbs are lit and all the components in the circuit are working.

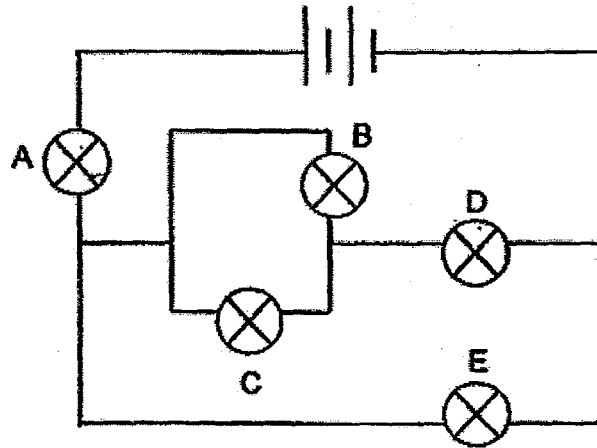

Which of the following correctly states the number of bulb(s) that would still be lit when one bulb is blown?

	Bulb that is blown	Number of bulb(s) still lit
(1)	A	1
(2)	C	4
(3)	D	3
(4)	E	2

17. Each of the electric circuits below has a steel rod, a wooden rod and a plastic rod.

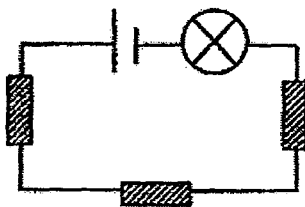

Circuit A

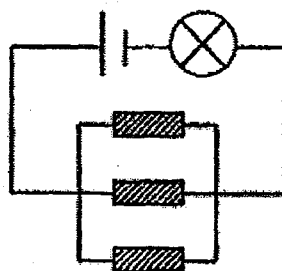

Circuit B

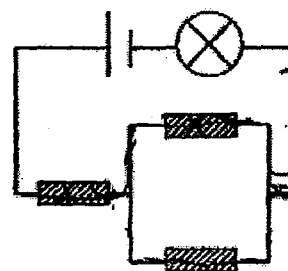

Circuit C

In which of the circuit(s) above would the bulb light up?

- (1) B only
- (2) A and C only
- (3) B and C only
- (4) A, B and C

18. Which of the following wastes electricity?

- (1) Turn on a fan instead of an air-conditioner.
- (2) Open the refrigerator door when necessary.
- (3) Use energy saving bulbs instead of filament bulbs.
- (4) Turn on the main power switch when appliances are not in use.

19. Three bar magnets, AB, CD and EF, can be arranged as shown below.



Which of the following can be another arrangement of the bar magnets?

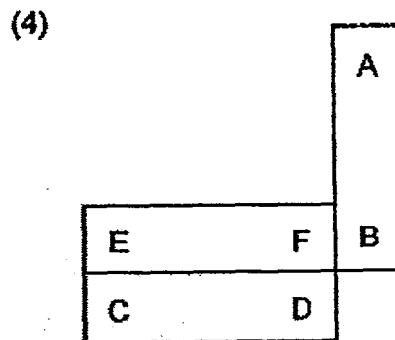
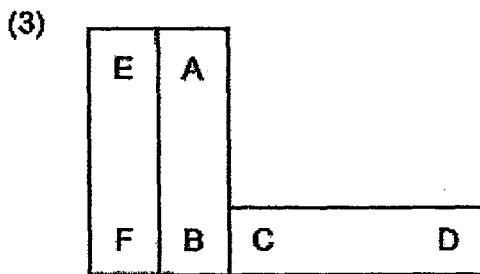
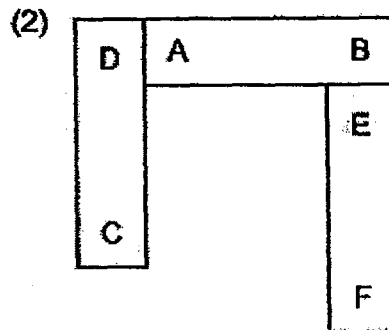
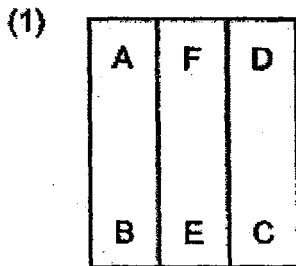

20. The set-up below shows a lighted torch shining at three wooden objects. They are placed at different positions, A, B and C, from the torch. The size of the objects is the same.

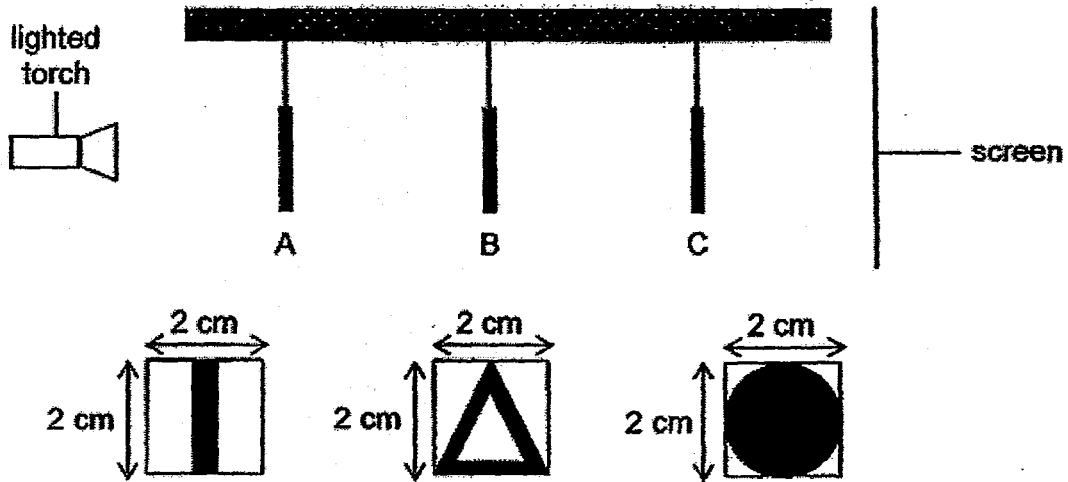

The diagram below shows the shadow of the objects on the screen.

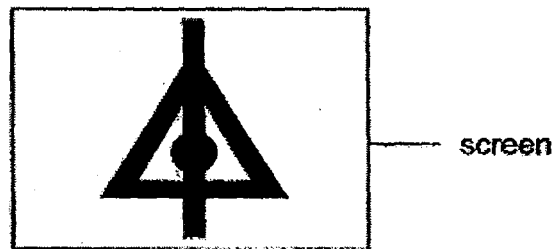

Which of the following correctly shows the objects at the positions, A, B and C?

	A	B	C
(1)			
(2)			
(3)			
(4)			

21. The diagram below shows a flask fitted with a stopper.

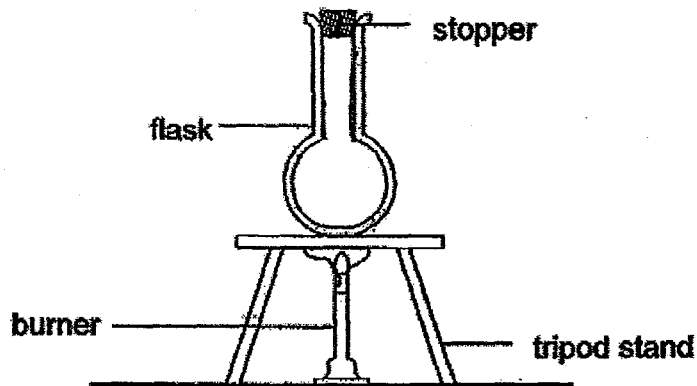

The flask was heated and after a minute, the stopper popped out. Which of the following explains why the stopper popped out?

- (1) The flask expanded.
- (2) The stopper expanded.
- (3) The air in the flask expanded.
- (4) The flask and the stopper expanded.

22. Three types of string, X, Y and Z, had weights hanging from them. The weights were increased until the strings broke. The maximum weight that the strings could hold before breaking is shown below.

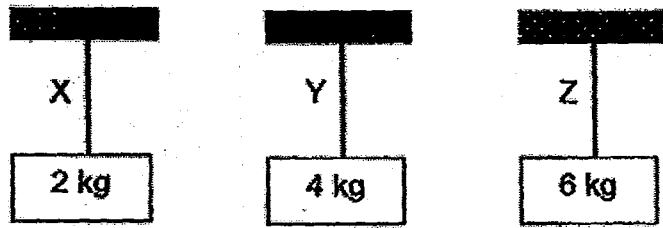

Which of the following shows a possible arrangement of the weights?

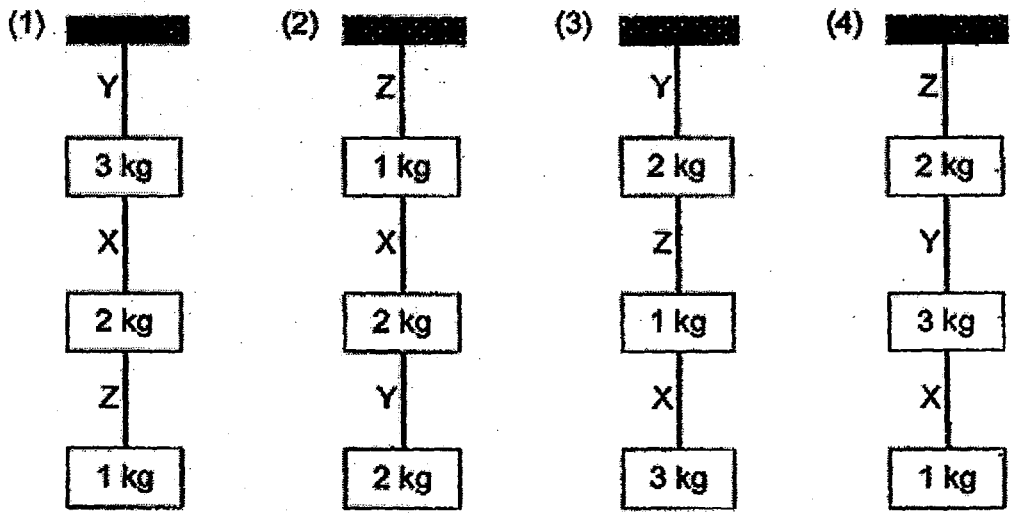



23. Tom prepared four slices of bread, A, B, C, and D. He placed each of the four slices of bread into identical plastic bags and sealed them as shown below. He put A and B in a refrigerator. He put C and D in a cupboard.

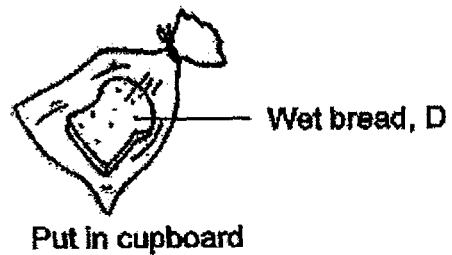
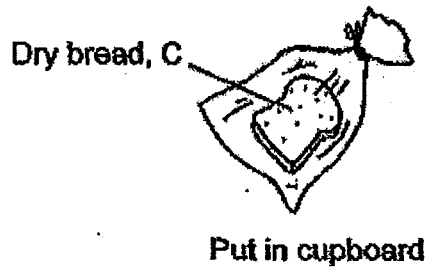
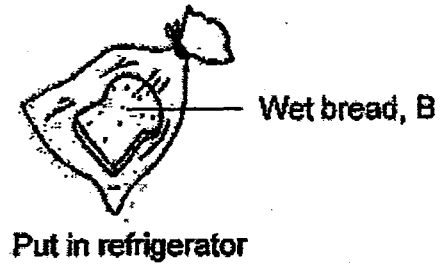
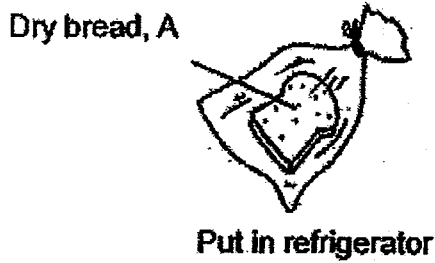

Which slice of bread would turn mouldy first?

- (1) A
- (2) B
- (3) C
- (4) D

24. The diagram below shows the life cycle of an animal.

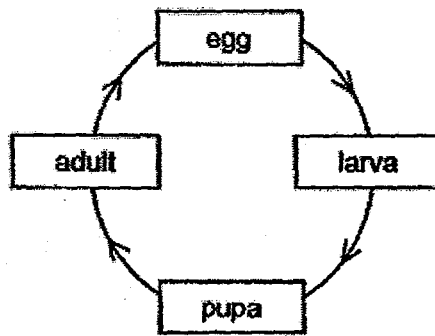

Which of the following animals go through the life cycle above?

- (1) Butterfly and frog
- (2) Mosquito and beetle
- (3) Chicken and cockroach
- (4) Cockroach and butterfly

25. Study the classification chart below and match the parts of the human body to the body systems, A, B, C and D.

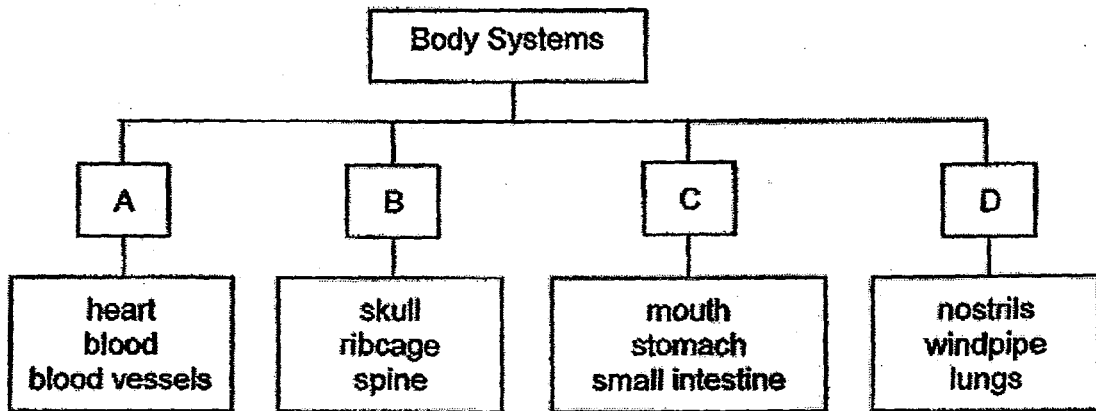

	A	B	C	D
(1)	Circulatory	Digestive	Skeletal	Respiratory
(2)	Respiratory	Skeletal	Digestive	Circulatory
(3)	Circulatory	Skeletal	Digestive	Respiratory
(4)	Respiratory	Digestive	Skeletal	Circulatory



## PRIMARY 5 END-OF-YEAR EXAMINATION 2015

Name: \_\_\_\_\_ ( )

Date: 30 October 2015

Class: Primary 5 ( )

Time: 8.00 a.m. to 9.25 a.m.

Duration: 1h 25min

Parent's Signature: \_\_\_\_\_

Marks: \_\_\_\_\_ / 30

## SCIENCE

### BOOKLET B

#### INSTRUCTIONS TO CANDIDATES

Write your name, register number and class.

Do not turn over this page until you are told to do so.

Follow all instructions carefully.

Answer all questions.

**Section B (30 marks)**

For the questions, 26 to 35, write your answers in the spaces provided.

26. The following statements describe the process of sexual reproduction in humans.

- A: A sperm fuses with the egg.
- B: Sperms swim towards the egg.
- C: The fertilised egg starts to divide to form more cells.
- D: The unborn baby develops in the womb as organs begin to form.

(a) Arrange the above statements, A, B, C and D, in the correct order in which they take place. [1]

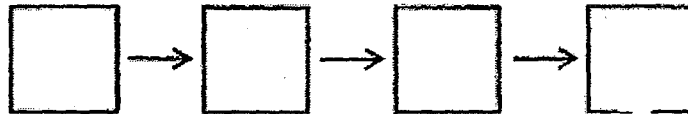

(b) The diagrams below show the reproductive parts of 3 women, X, Y and Z.

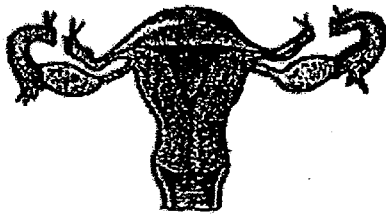

X



Y

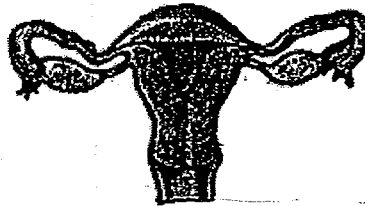

Z

Which woman, X, Y or Z, will be able to give birth? Explain why. [2]

---

---

---

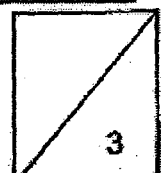

27. Sally observed three similar balsam plants, A, B and C with equally ripe fruits. Each plant was placed in a different room. Her observations are shown in the table below.

Balsam plant	A	B	C
Temperature of the room ( $^{\circ}\text{C}$ )	25	30	35
Time taken for the fruit to split (h)	4	2	1

- (a) Which variable was changed in Sally's experiment? [1]

---

---

- (b) Based on her observations in the table above, what can Sally conclude about the temperature of the room and the time taken for the fruit to split? [2]

---

---

---

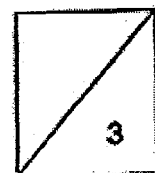

28. The water cycle is shown in the diagram below.

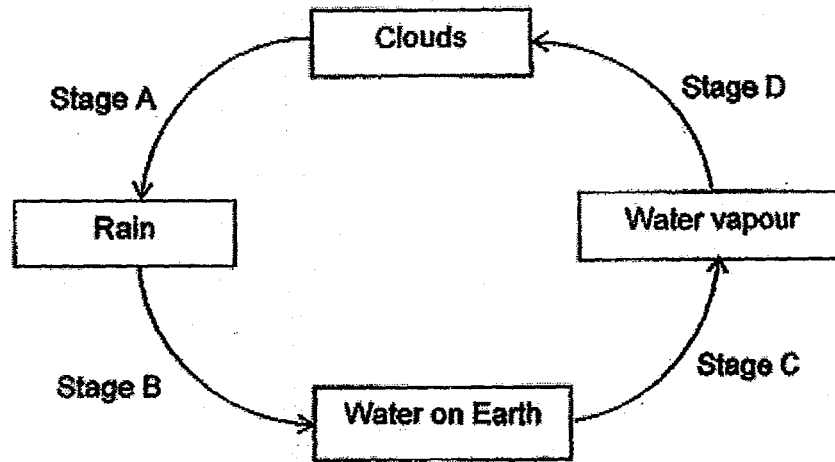

(a) Which stage(s), A, B, C and D, involve(s) a change in state of water? [1]

---

(b) A few plants were placed in a glass jar as shown in the diagram below. The jar was sealed tightly with a lid and was left in a garden for a few weeks.

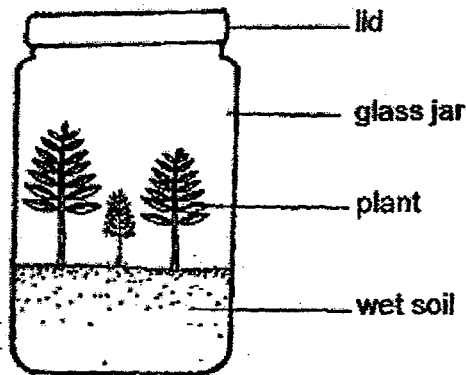

Explain how the plants in the jar obtained a constant supply of water over the few weeks. [2]

---



---



---

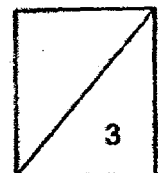

29. Tom had two containers, A and B, with the same capacity. He filled them with the same volume of water and placed them in a field.

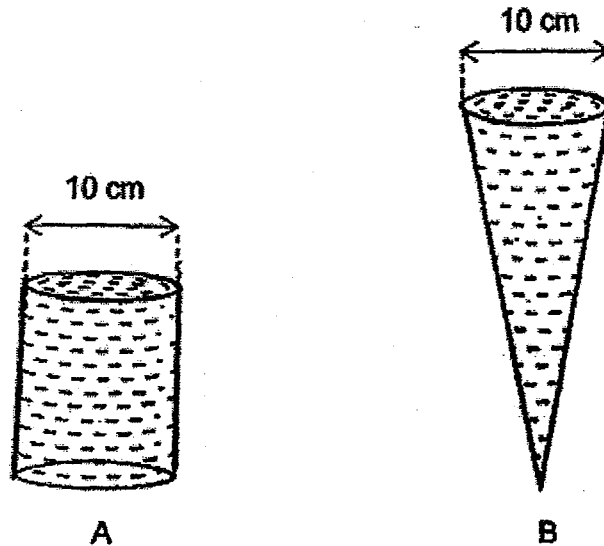

- (a) In which container, A or B, will the water take a longer time to evaporate? Explain why. [1]

---

---

- (b) After playing soccer, Tom switched on a fan and it blew at him for some time.

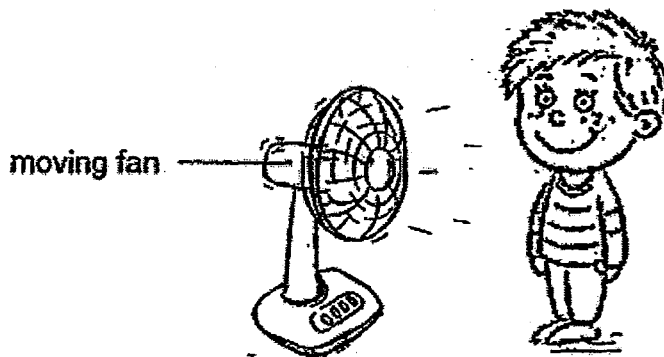

- Tom noticed his sweat dry faster when the fan blew at him. Explain why. [2]

---

---

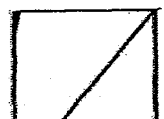

30. The diagrams below show two human body systems. Identify the systems in (a) and (b). Explain how they work together to remove carbon dioxide from the body in (c) and (d). [4]

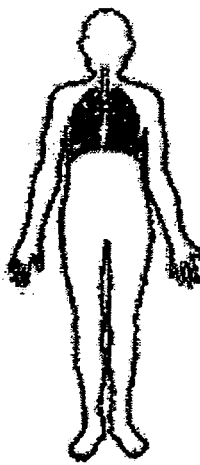
Explain how the systems work together to remove carbon dioxide from the body.	
 <p>(a) _____ system</p>	<p>(c) _____</p> <p>_____</p> <p>_____</p> <p>_____</p>
 <p>(b) _____ system</p>	<p>(d) _____</p> <p>_____</p> <p>_____</p> <p>_____</p>

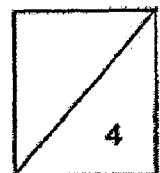



31. The diagrams below show 3 different cells, A, B and C.

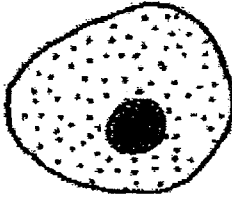

A

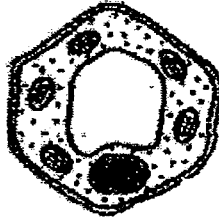

B

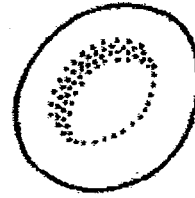

C

- (a) Based on your observations of the cells above, which cell, A, B or C, is a plant cell? Give two reasons. [2]

---

---

---

- (b) Genetic information is needed for a cell to reproduce. Which cell(s), A, B and C is are able to reproduce? Give a reason. [1]

---

---

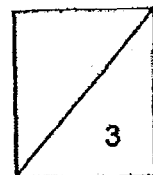

32. Study the electric circuit below.

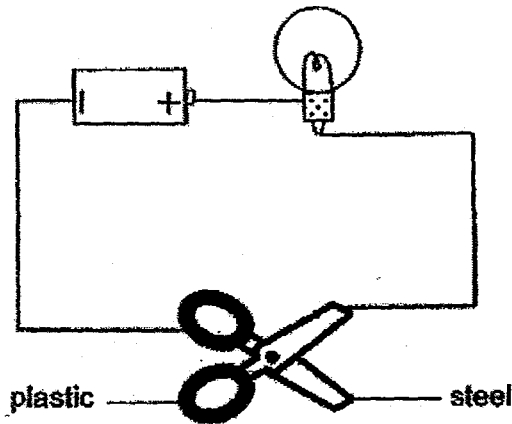

All the parts of the circuit are in good working condition.

(a) Explain why the bulb cannot light up.

[1]

---

---

(b) Using all parts of the circuit and without adding or removing any part of the circuit, suggest a change to the circuit to make the bulb light up.

[1]

---

---

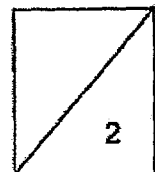

33. Bala has the following materials:

- 1 bulb
- 2 wires
- 3 batteries

Bala wants to construct a circuit with all the materials to make the bulb glow the brightest.

(a) Complete the circuit diagram in the box below to show how Bala should construct the circuit. [2]

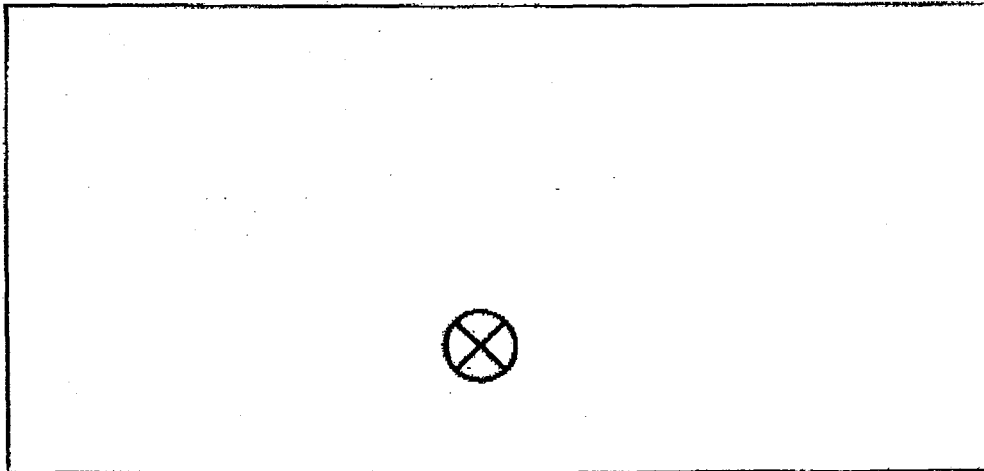

(b) In Bala's house, the lamps are arranged in parallel instead of in series.

What are two advantages of arranging the lamps in parallel? [2]

Advantage 1: \_\_\_\_\_

\_\_\_\_\_

\_\_\_\_\_

Advantage 2: \_\_\_\_\_

\_\_\_\_\_

\_\_\_\_\_

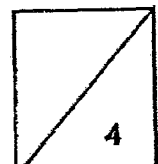

34. Simon set up the experiment below in a dark room with a lighted lamp.

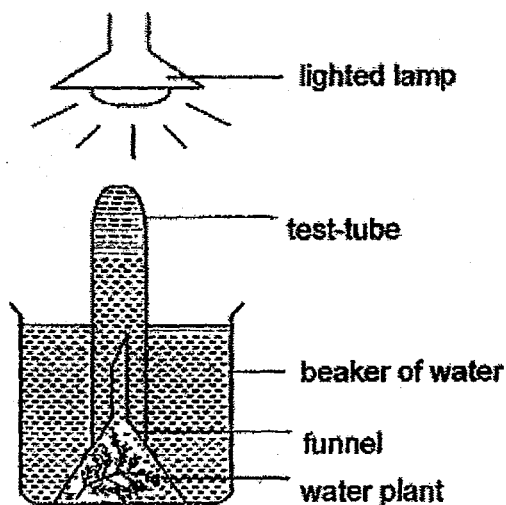

(a) What is the purpose of the lighted lamp in the experiment? [1]

---

---

(b) After a few minutes, Simon observed bubbles produced by the water plant in the test-tube. Name the gas found in the bubbles. [1]

---

(c) Draw a line graph below to show the relationship between the number of bubbles produced and the rate of photosynthesis. [1]

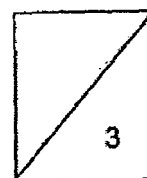
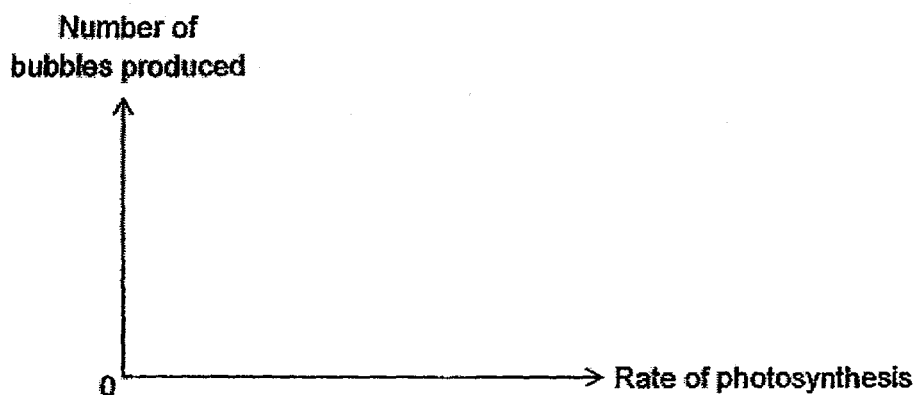

35. Study the flow chart below. A, B, C, D, E and F represent different materials.

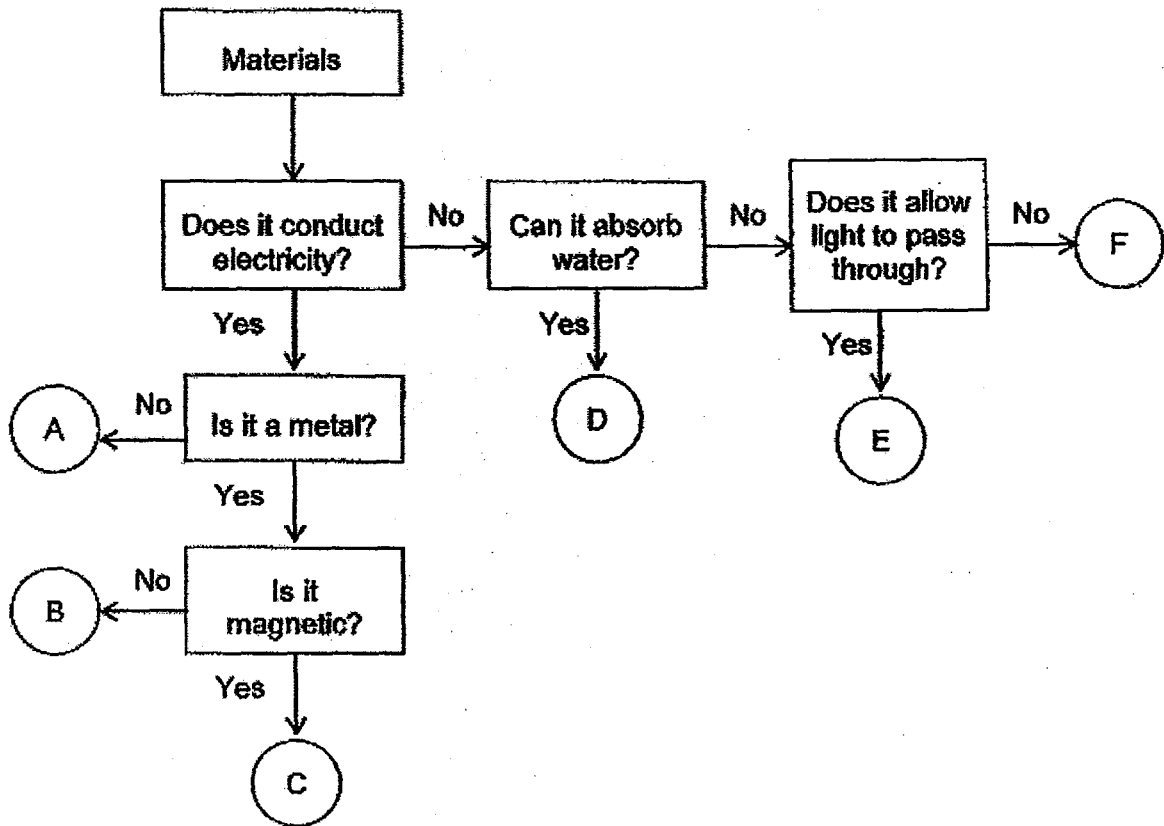

Identify the materials below. Write the letters, A, B, C, D, E or F, in the boxes provided. Use each letter only once. [2]

Material	Represented by letter
Ceramic	
Copper	
Glass	
Paper	

— End of Paper —

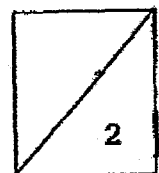



# Answer Key

EXAM PAPER 2015

SCHOOL : TAO NAN

SUBJECT : P5 SCIENCE

TERM : SA2

ORDER CALL : MR GAN @ 92998971 92475053 86065443

Q1	Q2	Q3	Q4	Q5	Q6	Q7	Q8	Q9	Q10
4	3	4	1	1	2	1	2	1	2
Q11	Q12	Q13	Q14	Q15	Q16	Q17	Q18	Q19	Q20
1	3	4	2	1	2	1	4	2	3
Q21	Q22	Q23	Q24	Q25					
3	4	4	2	3					

26)a)  $B \rightarrow A \rightarrow C \rightarrow D$

b) Woman 2. Woman X cannot give birth as the fallopian tube is cut, hence the sperm cannot meet the egg. Woman Y cannot give birth as it does not have the ovaries and cannot make eggs. Only woman Z can give birth as the sperm can meet the egg and the woman can give birth.

27)a) The temperature of the room.

b) As the temperature of the room increases, the time taken for the fruit to split decreases.

28)a) Stages C and D.

28)b)The plants would absorb the water in the wet soil. When the plants transpire, the water vapour transpired will condense on the inner surface of the glass jar and the water droplets flow back into the soil.

29)a)Container B. As the water in container B decreases, the exposed surface area of the water decreases.

b)The wind movement from the moving fan dried up Tom's sweat.

30)a)Circulatory.

b)respiratory.

c)The blood rich in carbon dioxide will be transferred back to the lungs by the heart.

d)The carbon dioxide will be breathed out by the lungs via the nose.

31)a)Cell B only cell B has the cell wall which only plant cells have. Cell B also has the chloroplast which helps a plant make food.

b)Cells A and B. Only cells A and B have the nucleus which contain genetic information.

32)a)The electric current flowing through the circuit can only be conducted through the steel part but cannot pass through the plastic as it is an insulator.

b)One can put both ends of the wire on the steel part only.

33)a)

