

Name: _____ ()

Class: Primary 5 _____

CHIJ ST NICHOLAS GIRLS' SCHOOL

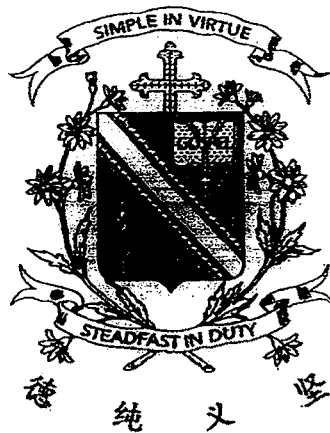

Primary 5
Semestral Assessment 2 – 2015
SCIENCE
BOOKLET A

29 October 2015

Total Time for Booklets A and B: 1 hour 45 minutes

**30 questions
60 marks**

**Do not open this booklet until you are told to do so.
Follow all instructions carefully.
Answer all questions.**

This booklet consists of 21 printed pages.

Section A (30 x 2 marks = 60 marks)

For each question from 1 to 30, four options are given. One of them is the correct answer. Make your choice (1, 2, 3 or 4). Shade the correct oval (1, 2, 3 or 4) on the Optical Answer Sheet provided.

1. Study the classification chart below carefully.

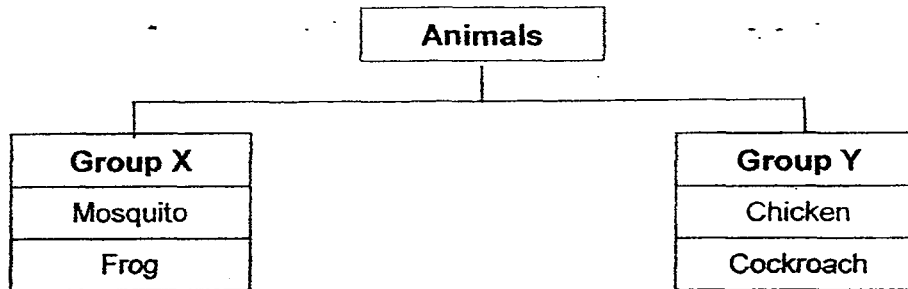

Which of one of the following shows the correct headings for Group X and Group Y?

	Group X	Group Y
(1)	Lay eggs	Do not lay eggs
(2)	Have wings	Do not have wings
(3)	Three body parts	More than three body parts
(4)	Spend part of life cycle in water	Spend entire life cycle on land

2. Which one of the following is the most likely reason for the male animal to produce millions of sperms?

- (1) To show that it is healthy.
- (2) To fertilise many eggs at a time.
- (3) To shorten the time needed for fertilisation.
- (4) To increase the chance of a sperm fertilising an egg.

3. The diagram below shows parts of a flower.

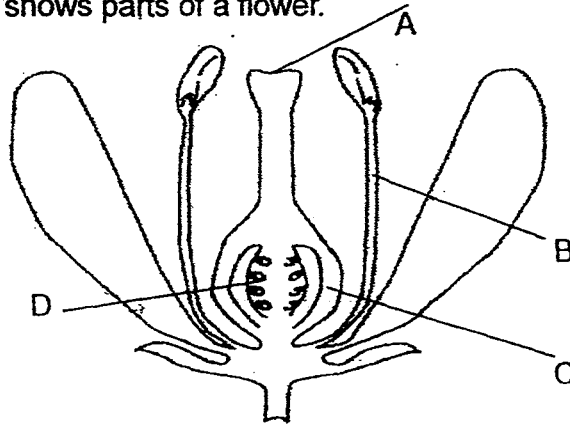

Which part, A, B, C or D, will develop into a seed?

- (1) A
- (2) B
- (3) C
- (4) D

4. Which of the following statements about birds are true?

- A All birds can fly.
- B All birds lay eggs.
- C All birds are meat eaters.
- D All birds have wings and feathers.

- (1) A and B only
- (2) B and C only
- (3) B and D only
- (4) C and D only

5. The diagram below shows the duration of the first 3 stages of the life cycles of insects A and B respectively.

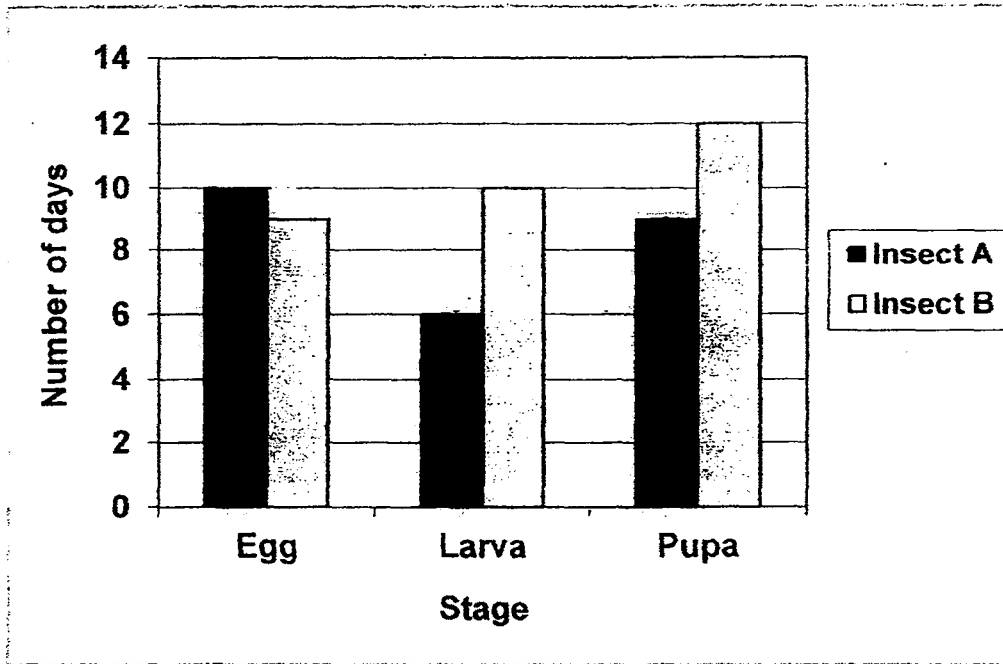

Which of the following is most likely to represent the stage of Insects A and B respectively 20 days after the eggs were laid?

	Insect A	Insect B
(1)	Pupa	Pupa
(2)	Larva	Pupa
(3)	Pupa	Adult
(4)	Larva	Larva

6. The diagram below shows how three body systems work together to transport substances to all parts of the body.

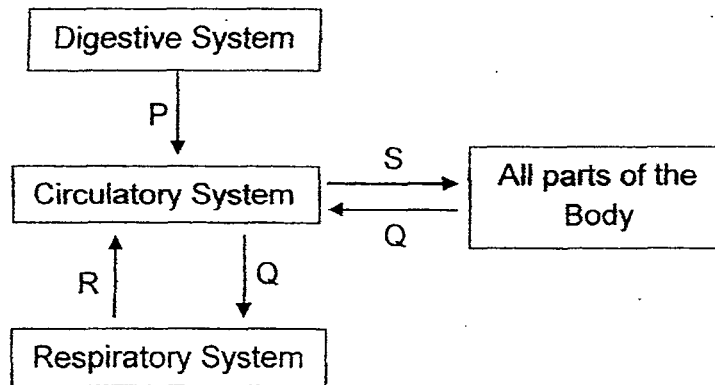

Which of the following substances could P, Q, R and S represent?

	P	Q	R	S
(1)	Undigested food	Oxygen	Carbon dioxide	Carbon dioxide and oxygen
(2)	Digested food	Carbon dioxide	Oxygen	Digested food, carbon dioxide and oxygen
(3)	Digested food	Carbon dioxide	Oxygen	Digested food and oxygen
(4)	Digested food	Oxygen	Carbon dioxide	Digested food and carbon dioxide

7. Alice cut 2 rings of different thickness, Part X and Part Y, from a stem and removed them from the plant as shown below.

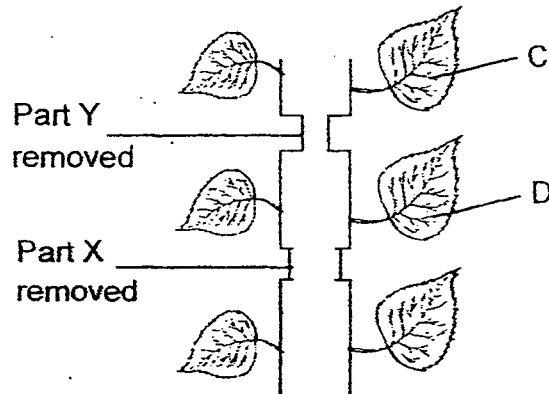

She recorded her observations of Leaves C and D after 1 week in the table below.

Leaf	Observations
C	Brown and wilting
D	Remains green and healthy

Which one of the following correctly states the parts that were removed?

	Part X	Part Y
(1)	Food-carrying tubes only	Food-carrying tubes only
(2)	Food-carrying tubes only	Food-carrying tubes and water-carrying tubes
(3)	Food-carrying tubes and water-carrying tubes	Food-carrying tubes only
(4)	Food-carrying tubes and water-carrying tubes	Food-carrying tubes and water-carrying tubes

8. Tiffany carried out an experiment to find out if the colour of a flower would affect the number of insects it attracts. The table below shows the characteristics of four types of flower P, Q, R and S.

Flower	Petal		Smell
	Size	Colour	
P	Large	Brightly-coloured	Scented
Q	Small	white	Scented
R	Large	white	Scented
S	Small	Brightly-coloured	Unscented

Which two flowers should she choose in order to conduct a fair experiment?

- (1) P and R only
 - (2) P and S only
 - (3) Q and S only
 - (4) S and R only
9. What will happen to the flower after fertilisation has taken place?

- A The petals will fall off.
- B Ovary will develop into a fruit
- C Filament will remain on the fruit.
- D Pollen will grow a tube down the style.

- (1) A only
- (2) A and B only
- (3) B and C only
- (4) C and D only

10. Which one of the following statements about human reproduction is false?

- (1) All eggs produced by the ovaries develop into babies.
- (2) The fertilized egg develops into a foetus in the mother's womb.
- (3) The fertilized egg divides to form many cells and they form the different parts of the developing baby.
- (4) During fertilization, only one sperm will fuse with the egg while the remaining sperms will eventually die.

11. Lucie made a bag from a special kind of material and filled it with a starch solution. The bag was then lowered into a glass container filled with some iodine solution. Six hours later, the starch solution in the bag turned dark blue. However, the colour of the iodine solution in the glass container remained unchanged.

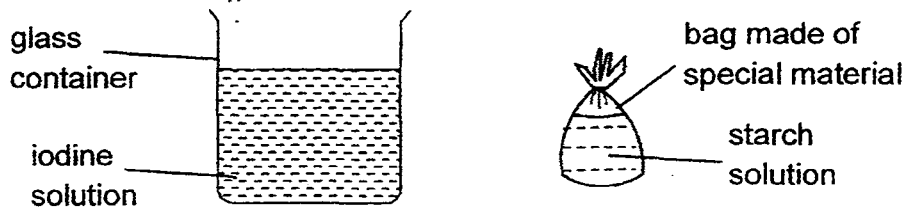

What caused the starch to turn dark blue?

- (1) The material of the bag interacted with the iodine solution.
- (2) The material of the bag interacted with the starch solution.
- (3) The iodine solution entered the bag and interacted with the starch solution.
- (4) The starch solution was able to exit from the bag and interact with the iodine solution.

12. The diagram below shows the life cycle of a flowering plant.

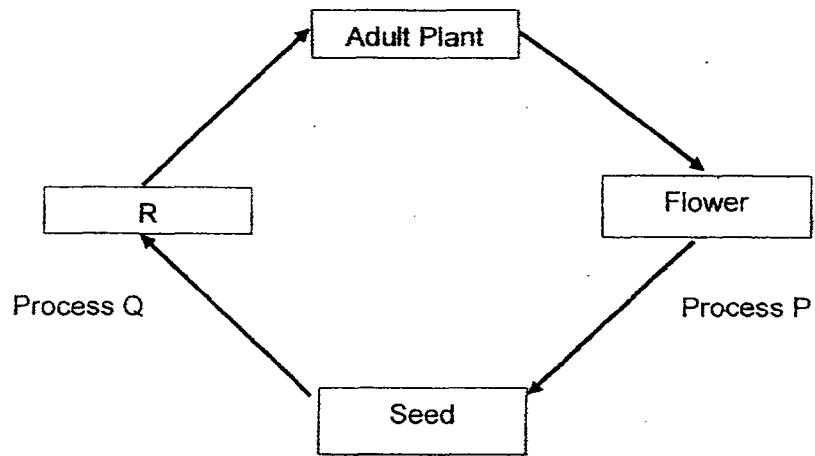

Which one of the following shows the correct representation of P, R and Q?

	P	Q	R
(1)	Germination	Fertilisation	Seedling
(2)	Fertilisation	Pollination	Fruit
(3)	Pollination	Germination	Fruit
(4)	Fertilisation	Germination	Seedling

13. Study the flowchart below.

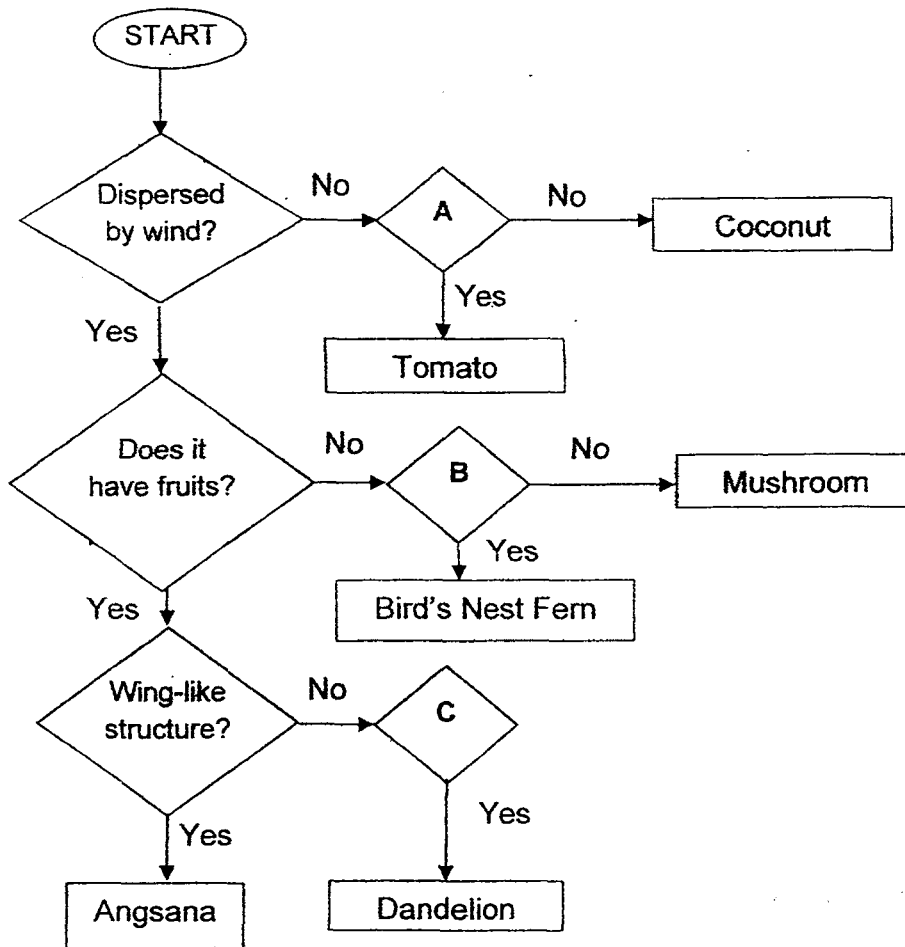

What do A, B and C in the flowchart represent?

	A	B	C
(1)	Are the leaves big?	Is the fruit edible?	Feather-like structure?
(2)	Does it grow in soil?	Is the fruit wall fibrous?	Stiff hair on fruit / seed?
(3)	Dispersed by animal?	Spore bags under leaves?	Hair-like structure?
(4)	Dispersed by wind?	Does it bear flower?	Is the plant edible?

14. Jane set up four electrical circuits, P, Q, R and S, using identical batteries and bulbs.

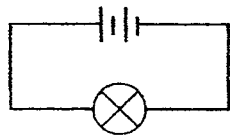

Circuit P

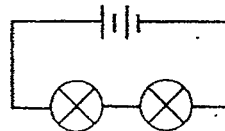

Circuit Q

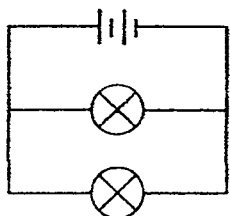

Circuit R

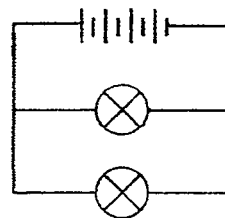

Circuit S

Which two of the above circuits have bulbs of equal brightness?

- (1) Circuits P and R
 - (2) Circuits P and S
 - (3) Circuits Q and S
 - (4) Circuits R and Q
15. May wanted to find out how the temperature of the surrounding affects the rate of evaporation of water.

Set-up	Exposed surface area of container (cm ²)	Volume of water in container (ml)	Temperature (°C)	Wind
A	150	350	28	present
B	100	300	33	absent
C	100		28	absent
D	150	350	33	absent

Based on the table above, which two set-ups should May use to conduct her experiment?

- (1) A and B
- (2) A and D
- (3) B and C
- (4) C and D

16. The experiment shown below is carried out in a dark room.

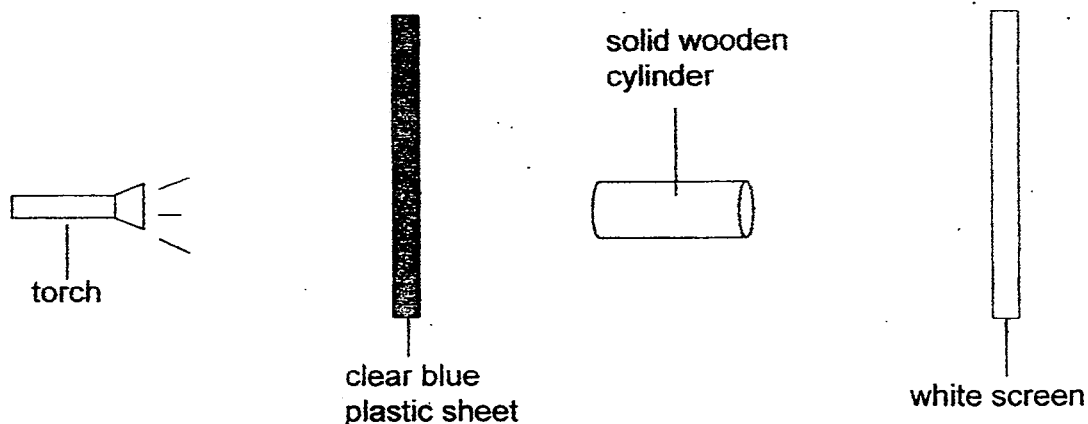

Which of the following correctly shows the shadow cast on the screen when the torch is switched on?

- (1) Blue
- (2) White
- (3) Blue
- (4) White

17. The table below shows the melting points and boiling points of four substances, W, X, Y and Z.

Substance	Melting point (°C)	Boiling point (°C)
W	28	54
X	45	94
Y	16	71
Z	0	100

At which temperature would only one of the 4 substances W, X, Y and Z, be in its gaseous state?

- (1) 14 °C
 (2) 62 °C
 (3) 75 °C
 (4) 98 °C

18. The diagram below represents the changes in states of water in a water cycle. V, W, X and Y represent the processes involved.

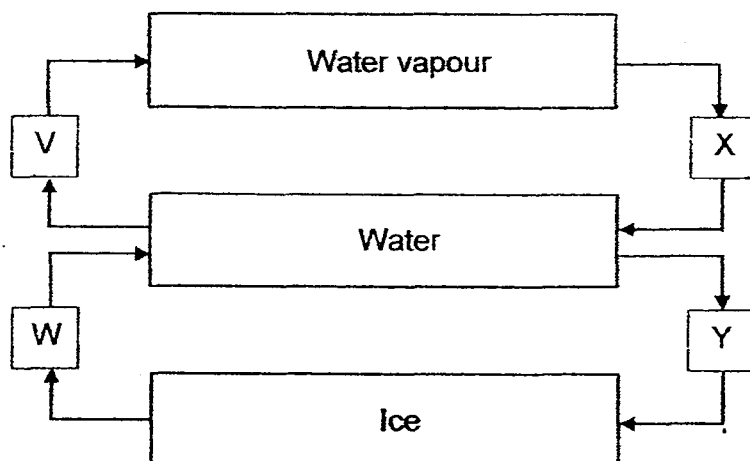

Which of the following processes, V, W, X and Y, involve heat loss to the surroundings?

- (1) V and W
 - (2) V and X
 - (3) X and Y
 - (4) W and Y
19. In the morning, Zane noticed some water droplets on one of the leaves in her garden though it did not rain the night before.

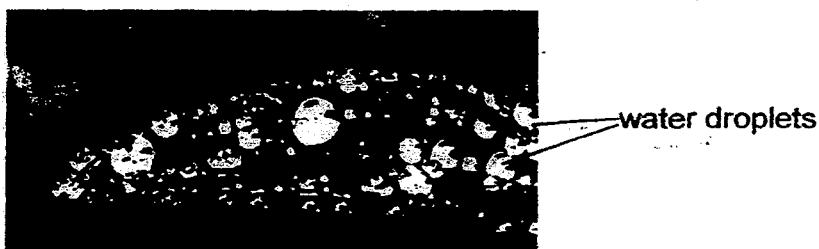

Which one of the following best explains her observation?

- (1) Water from the leaves evaporated into the air.
- (2) Water vapour from the surrounding air condensed on the leaves.
- (3) Water droplets from the surrounding air evaporated on the leaves.
- (4) Water escaped from the leaves and formed water droplets on the leaves.

20. Three metal balls, A, B and C, of the same size are placed at different positions between a light source and a white screen as shown in the diagram below.

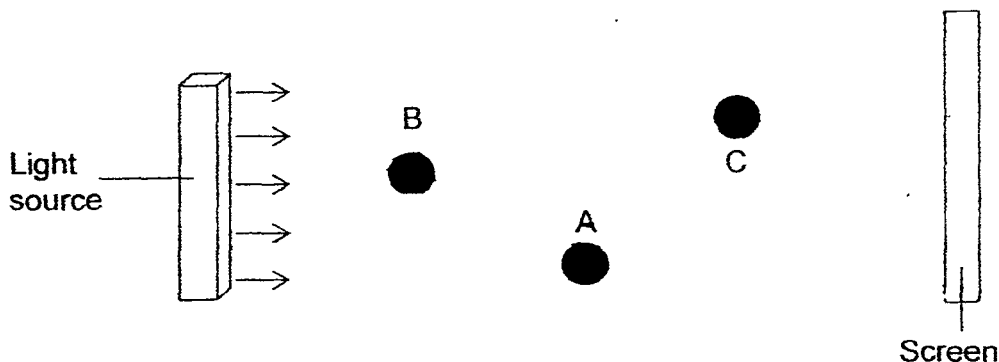

When the light source is switched on, which one of the following diagrams correctly shows the shadows cast on the screen by the metal balls?

(1)

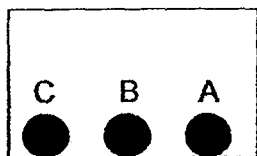

(2)

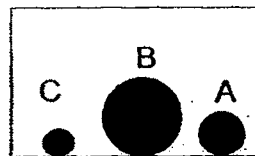

(3)

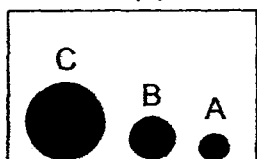

(4)

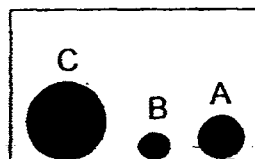

21. A block of ice was placed on a tray and left at room temperature for 3 minutes.

Which one of the following statement is true?

- (1) The temperature of the block of ice is 0°C .
- (2) The temperature of the block of ice increases.
- (3) The temperature of the block of ice decreases.
- (4) The temperature of the water around the block of ice is less 0°C .

22. Study the 4 set ups, A, B, C and D; shown below.

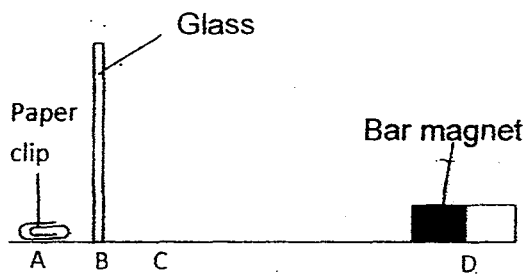

Set-up A

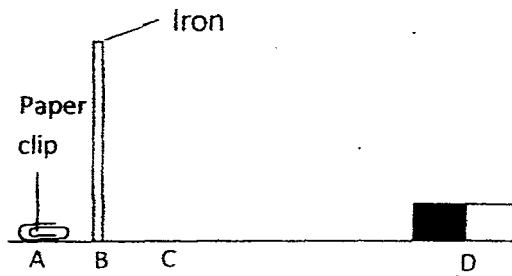

Set-up B

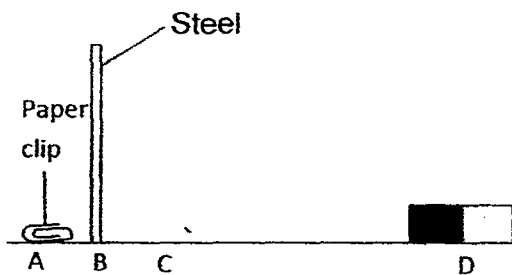

Set-up C

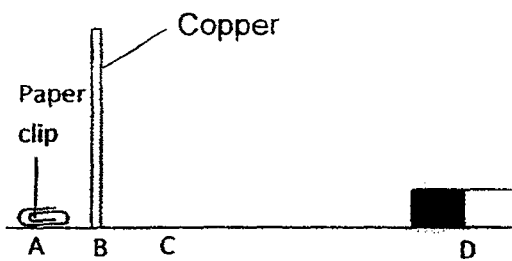

Set-up D

When the magnet is placed at position C, in which set-up(s) would the paper clip move towards position B?

- (1) B only
- (2) A and D only
- (3) B and C only
- (4) B, C, D only

23. Jen set up a circuit as shown below. She observed that only bulb Q lit up.

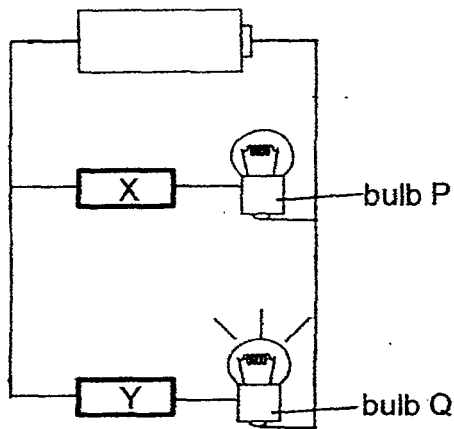

She then changed the positions of bulb Q and P as shown below, and observed that no bulb lit up.

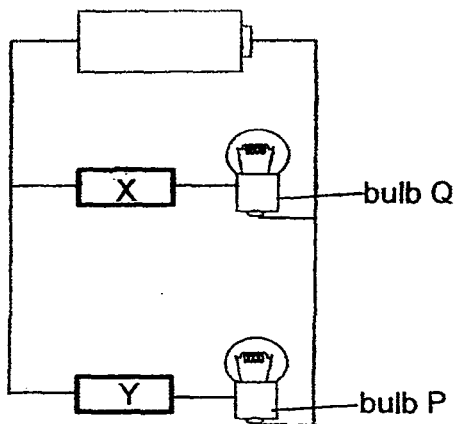

Based on her observation above, which one of the following is correct?

	Electrical insulator	Fused bulb
(1)	X	P
(2)	X	Q
(3)	Y	P
(4)	Y	Q

24. Evelyn set up an experiment as shown below. Pins, P, Q, R and S, are held in the different positions on the rods with wax. As the rods get heated up, the pins on the rods begin to fall off one by one.

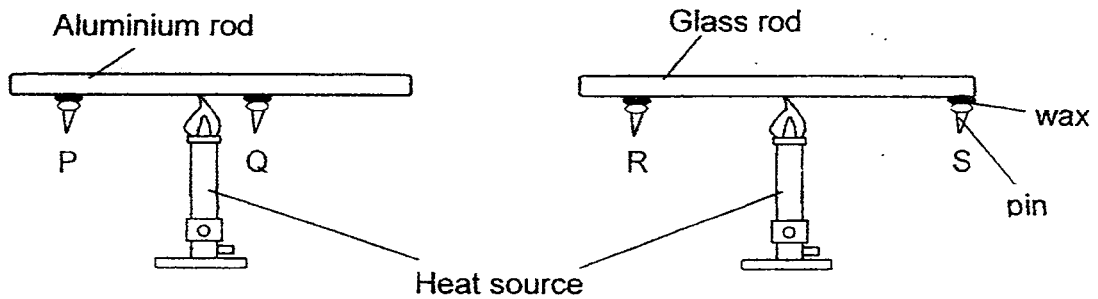

Which of the following shows the correct order of the pins that would drop from the rods?

	Fastest \longrightarrow Slowest			
(1)	Q	R	P	S
(2)	R	S	Q	P
(3)	P	Q	S	R
(4)	Q	P	R	S

25. Which one of the following does not help in the conservation of water?

- (1) Wash the car with a water hose.
- (2) Turn off the tap while soaping.
- (3) Wash clothes only when the washing machine has a full load.
- (4) Water the plants with water that has been used to wash rice.

26. Joan set up a circuit as shown below.

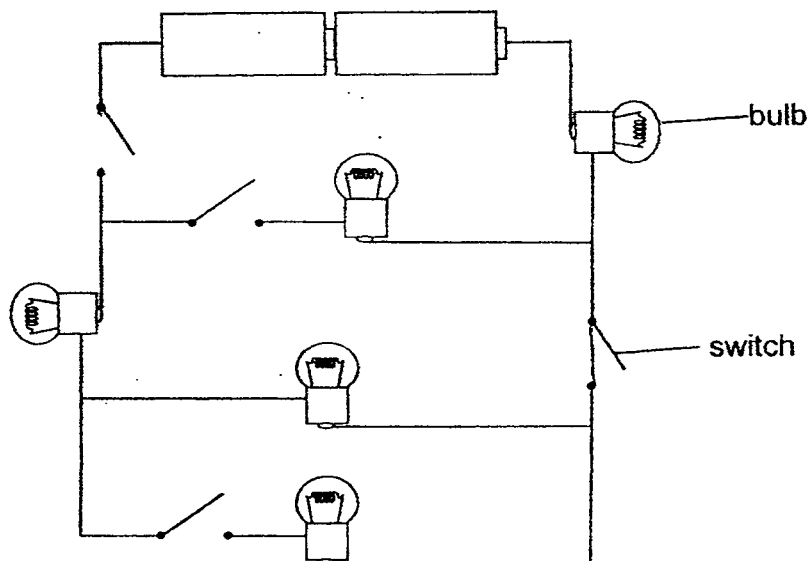

What is the minimum number of switches to be closed in order for 3 bulbs to be lit?

- (1) 1
- (2) 2
- (3) 3
- (4) 4

27. Peter conducted an experiment using the set-up as shown below.

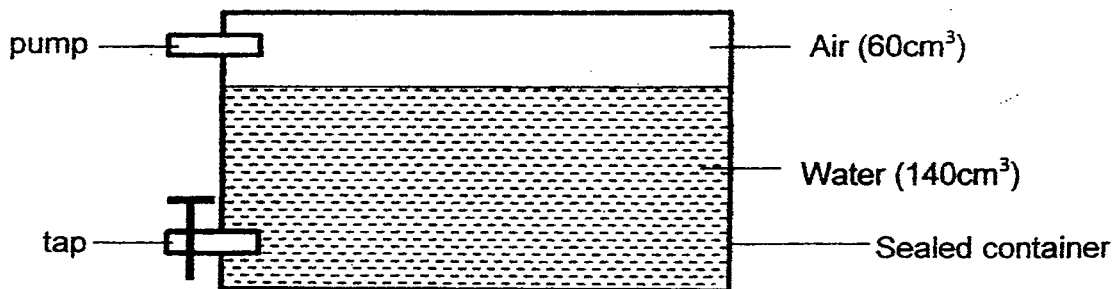

He used the tap to remove 30cm^3 of water. He then used the pump to add 20cm^3 of air into the container. What was the final volume of air in the container?

- (1) 60cm^3
- (2) 80cm^3
- (3) 90cm^3
- (4) 110cm^3

28. A bar magnet was broken into three pieces, P, Q, and R as shown below.

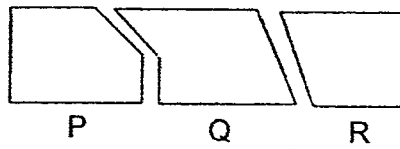

Which of the following is not possible when two broken pieces of magnets are brought together?

(1)

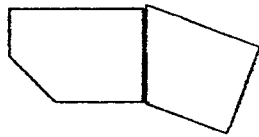

(2)

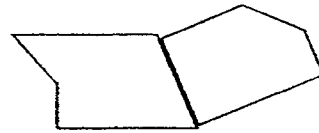

(3)

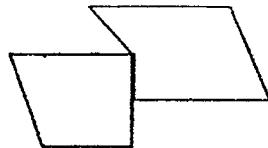

(4)

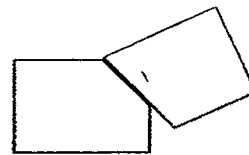

29. Simon placed a piece of styrofoam in a basin of water as shown in the diagram below. It was observed that the piece of styrofoam floated on the water.

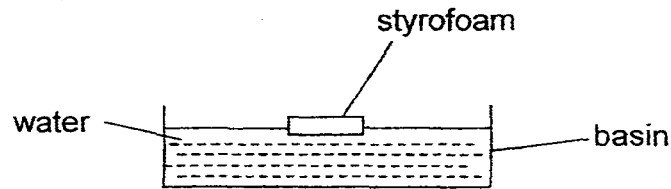

He then inverted a transparent plastic cup over the styrofoam piece and observed the changes in the plastic cup as shown in the diagram below.

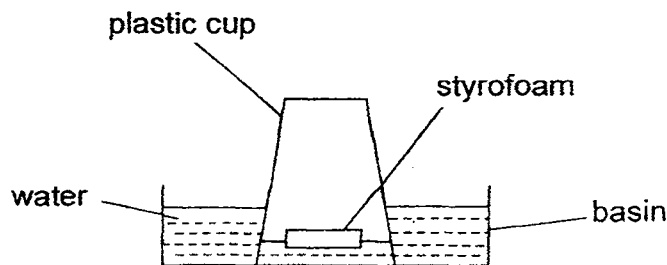

He repeated the experiment by making a hole at the base of the transparent plastic cup and recorded his observation.

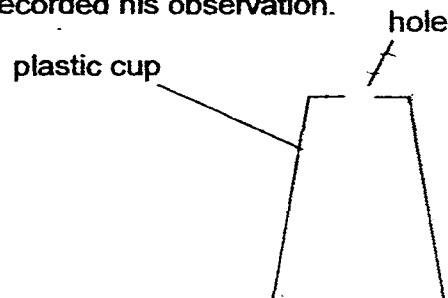

Which of the following is most likely to show his observation when he repeated the experiment?

(1)

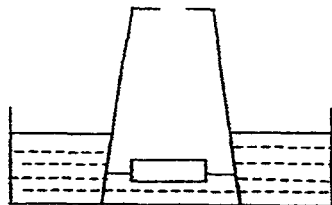

(3)

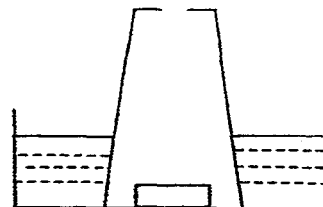

(2)

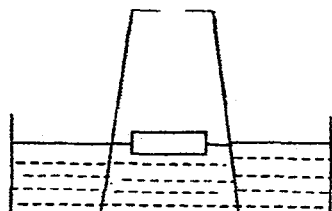

(4)

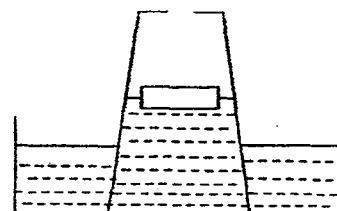

30. Study the diagram below.

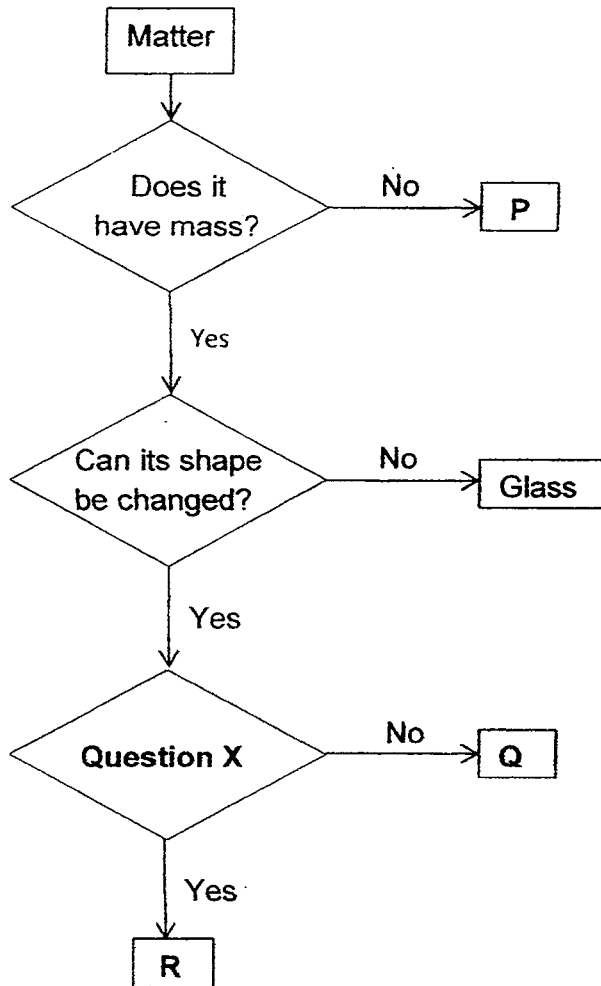

Which of the following correctly states what P, Q, R and Question X are?

	Question X	P	Q	R
(1)	Can it change state?	Steam	Sand	Ice cube
(2)	Does it occupy space?	Fire	Sound	Water
(3)	Can it be compressed?	Sunlight	Oxygen	Orange juice
(4)	Does it have a definite volume?	Shadow	Carbon dioxide	Water

End of Booklet A



Name : _____ ()

Class : Primary 5 _____

CHIJ ST NICHOLAS GIRLS' SCHOOL



Primary 5
Semestral Assessment 2 – 2015
SCIENCE
BOOKLET B

29 October 2015

Total Time for Booklets A and B: 1 hour 45 minutes

14 questions
40 marks

Do not open this booklet until you are told to do so.
Follow all instructions carefully.
Answer all questions.

This paper consists of 15 printed pages.

Booklet A	60
Booklet B	40
Total	100

Parent's Signature/Date

31. Study the chart below.

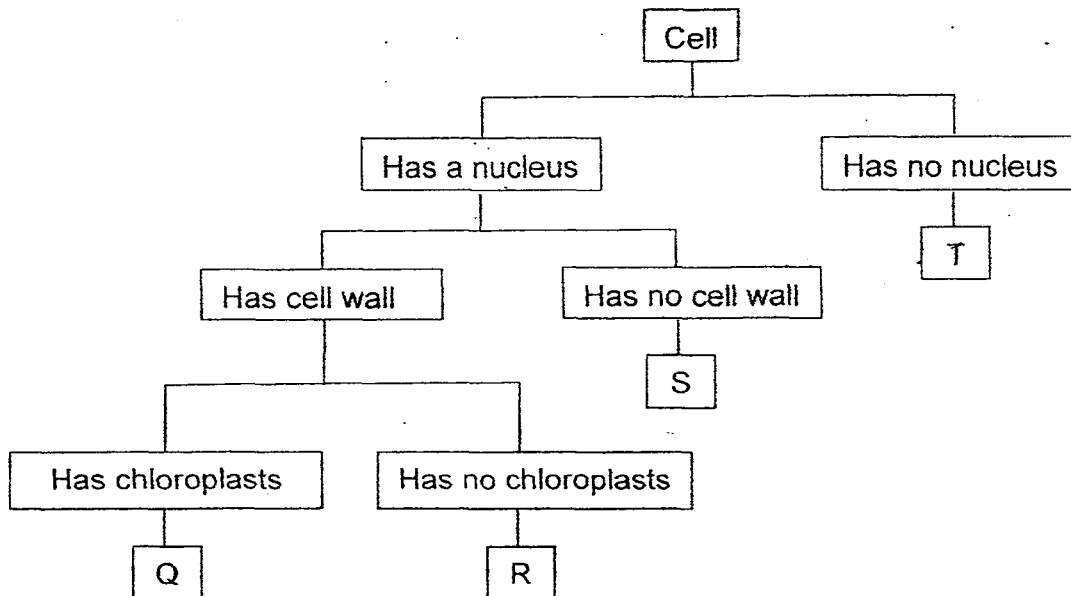

Based on the information above, answer the following questions.

(a) State one difference between cell Q and cell S. [1]

(b) Which cell is likely a root cell? Explain your answer. [1]



32. William and Samuel carried out an experiment to investigate the effect of exercise on their breathing rates.

They measured their breathing rates before starting their exercises. Then they did some exercises for 15 minutes and measured their breathing rates immediately after. They then measured their breathing rates again every two-minute for 10 minutes while resting.

They recorded their breathing rates before and after the exercise in the table below.

	Breathing Rate per minute						
	Before exercise	No. of minutes after exercise					
		0	2	4	6	8	10
William	14	38	30	22	16	14	14
Samuel	16	42	36	30	24	20	16

- (a) The graph below shows how Samuel's breathing rate changes after the exercise. Based on the results shown above, draw a graph to show how William's breathing rate changes after the exercise. [1]

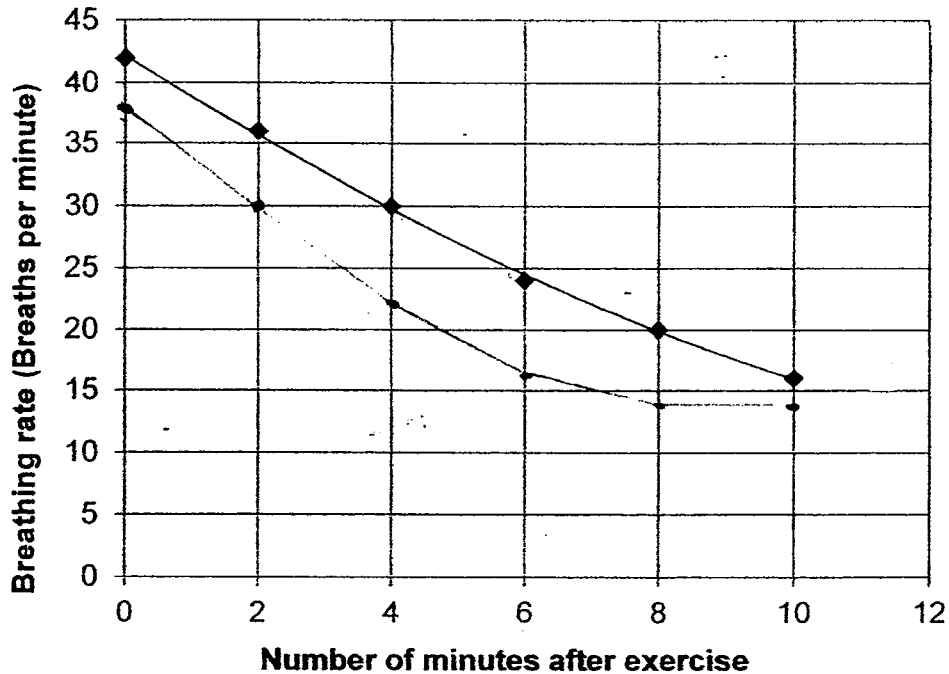

- (b) Based on the information given above, which of the boys, William or Samuel, made a quicker recovery from the exercise? Give a reason for your answer. [1]

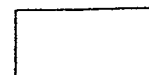

33. Aiko wanted to find out if carbon dioxide is given out when seeds germinate. She conducted an experiment with the set up shown below. The set up was left in a warm dark place for 2 days. After 2 days, Aiko observed that the seeds had germinated and the limewater in the test tube had turned chalky.

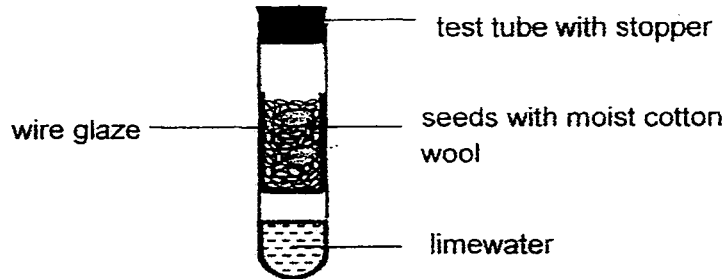

- (a) Based on the results of her experiment, what can Aiko conclude about germination and the gas given out? [1]

- (b) Explain why having a stopper to seal up the test tube would ensure that the result is reliable. [1]

- (c) Suggest a control set up for this experiment. [1]



34. Madeline conducted an experiment to determine how the number of wing-like structures of fruit X affects the duration it remains in the air.



Fruit X with 2 wing-like structures

She dropped the fruit from a fixed height and recorded the time taken for the fruit to reach the ground. She repeated the experiment using the same fruit but with the wing-like structures cut off, one at a time, as shown below.



Fruit X with 1 wing-like structure



Fruit X with no wing-like structure

For each of the experiment carried out, she recorded the results in the table below.

Time taken for the fruit to reach the ground (seconds)		
Fruit X with 2 wing-like structures.	Fruit X with 1 wing-like structure.	Fruit X with no wing-like structures.
12.9	8.4	3.1

- (a) What conclusion can be drawn from the results above? [1]

- (b) What advantage does a seed have if it is able to take a longer time to reach the ground once it has been dispersed from its parent plant? [1]

- (c) Madeline used the same seed for the experiments in order for the results to be reliable. Give 2 reasons why the same seed must be used for the experiments. [1]



35. The diagram below shows a human female reproductive system.

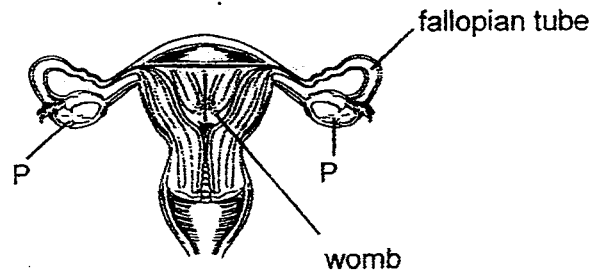

(a) Name the part labelled P and state its function. [1]

The diagram below shows the female reproductive system of a bird. The part labelled W has the same function as the part labelled P in the human reproductive system.

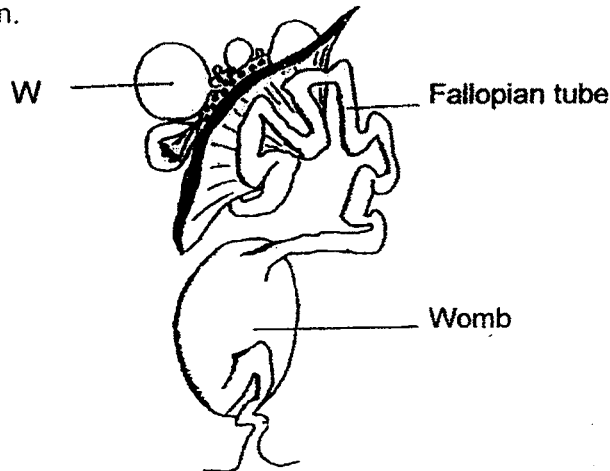

The human female reproductive system has 2 of its parts labelled P whereas the female bird reproductive system has only 1 of its parts labelled W.

(b) What advantage has the human female reproductive system over the bird female reproductive system? [1]

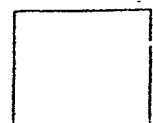

36. Roger grows 3 plants in his garden as shown in the diagram below.

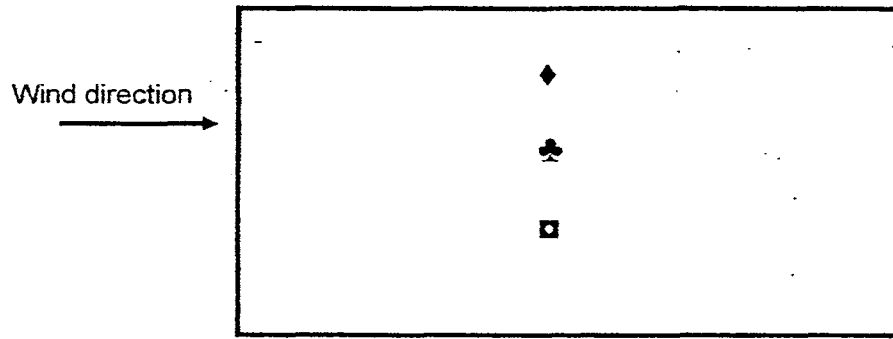

After 30 days, Roger found more plants growing in his garden.

KEY:

- ◆ - plant 1
- ♣ - plant 2
- - plant 3

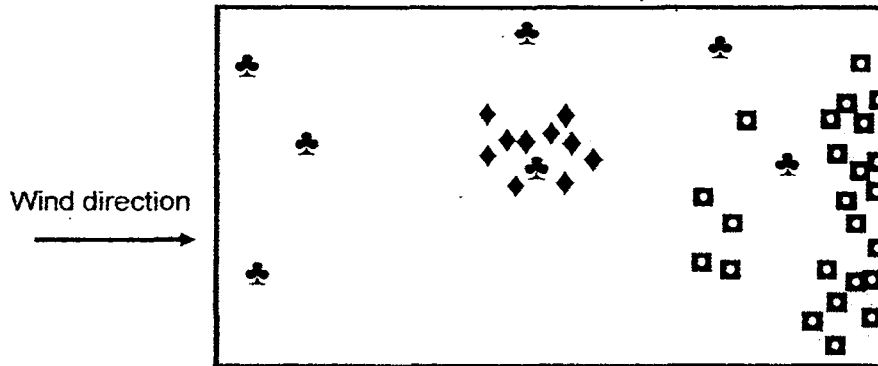

State the methods of dispersal of fruits/ seeds of plants 1 and 2 and give a reason for each of your answers. [3]

Plant 1: _____

Reason: _____

Plant 2: _____

Reason: _____



37. An experiment was set up as shown below.

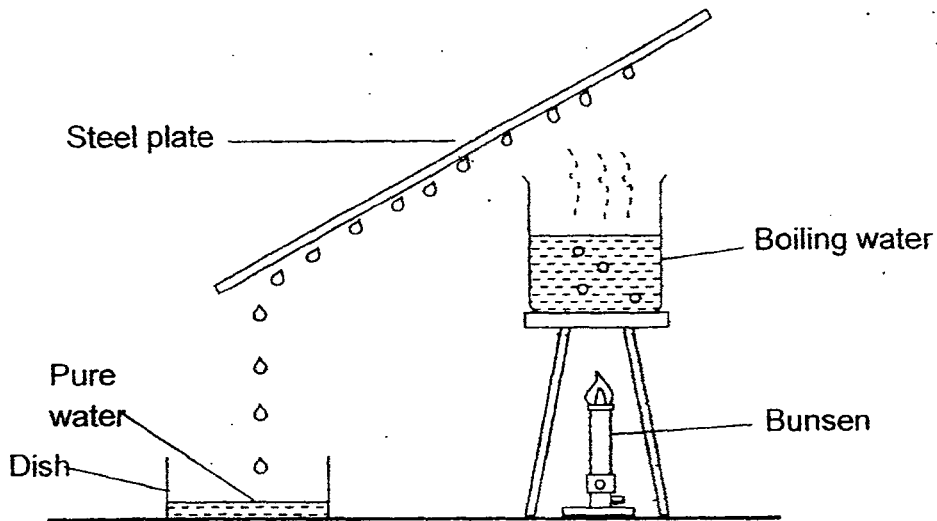

(a) Explain how pure water was formed and collected in the dish.

[2]

(b) Water droplets were observed to form quickly on the steel plate at the start of the experiment. However, after a while, fewer and fewer water droplets were formed on the plate. Give a reason for this observation.

[1]

(c) What would you observe on the amount of water collected in the dish if the steel plate is replaced with a plastic plate?

[1]



38. A boy entered a room with a lighted lamp and saw the image of the soccer ball in the mirror.

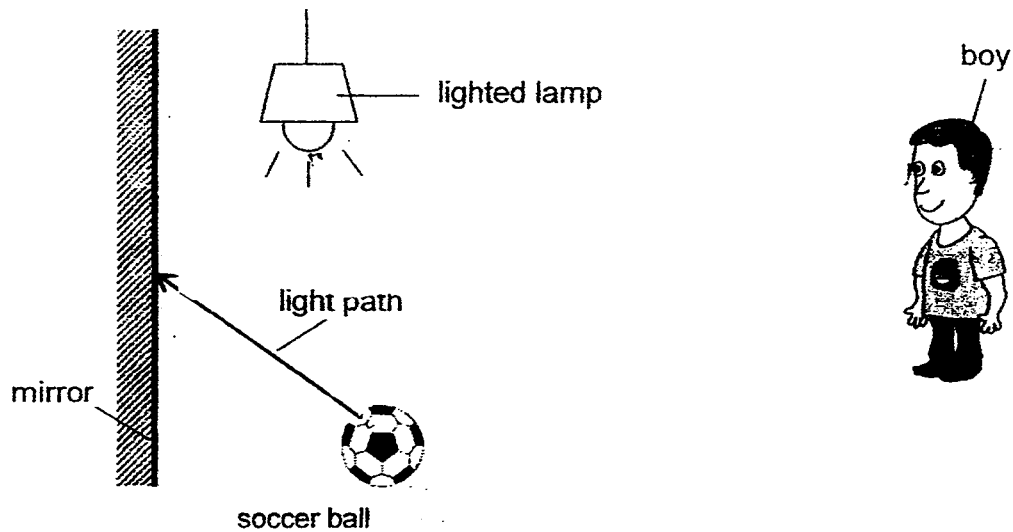

- (a) On the diagram above, draw **two** arrows to complete the path of light to show how the boy was able to see the image of the soccer ball in the mirror from where he was standing.

[2]

- (b) The soccer ball has cast a shadow on the floor. Explain how the shadow was formed.

[1]

- (c) Suggest one way to cast a bigger shadow of the soccer ball on the floor without moving the light source.

[1]



39. Titus carried out an experiment using the set up shown below. The conical flask was placed into a basin of boiling water.

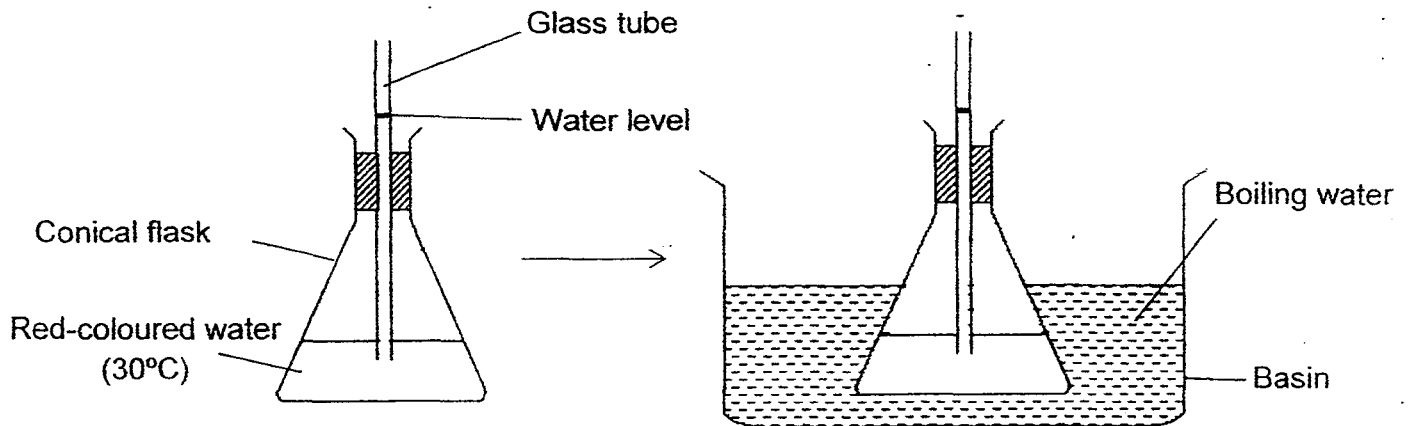

- (a) Titus observed the water level in the glass tube. Will the water level increase, decrease or remain the same? [1]

After 20 seconds: _____

After 1 minute: _____

- (b) Explain your answer in (a).

Qi Yue took the Mass Rapid Transit (MRT) to school one morning. She noticed that there were gaps between the metal rails of the MRT track as shown below.

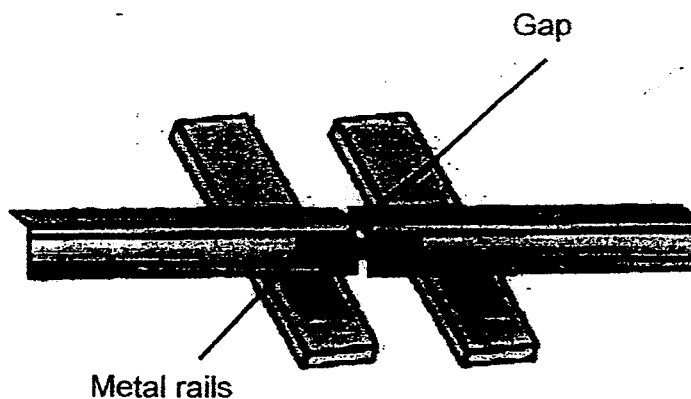

- (c) Why is there a need to have gaps between the metal rails of the MRT track? [1]

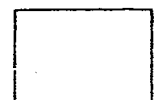

40. Jerry wanted to find out the factors that affect the rate of evaporation of water. He filled containers, A and B, with 200cm^3 of water and placed them on a lever balance as shown below.

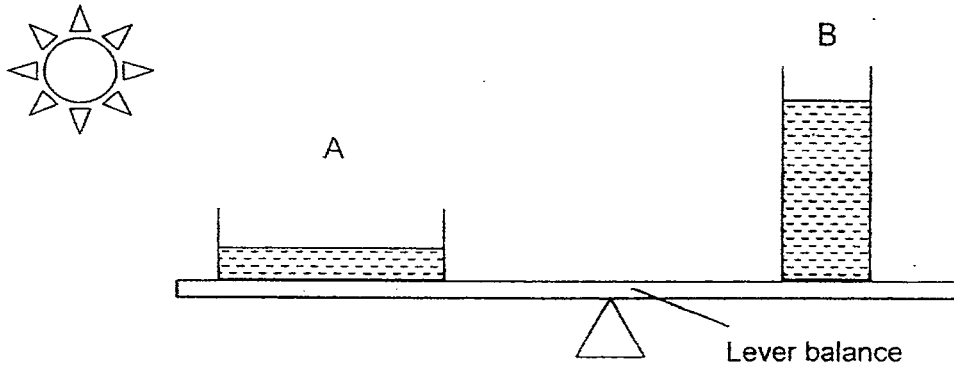

- (a) What factor is Jerry investigating in the experiment? [1]

- (b) What should Jerry record at the end of the experiment for him to conclude about the relationship between the factor he is investigating in (a) and the rate of evaporation? [1]

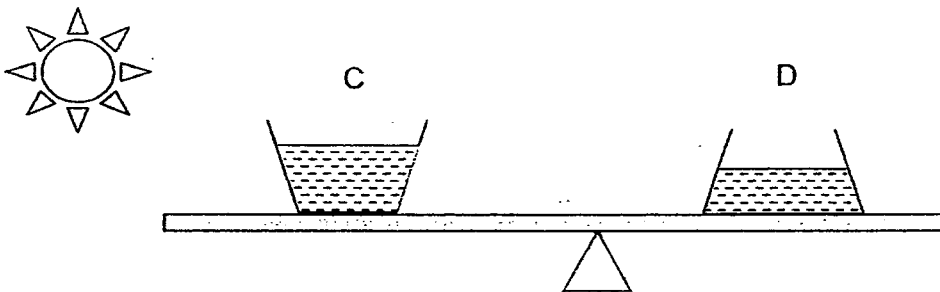

- (c) Jerry wanted to repeat the experiment with containers, C and D, as shown above, to confirm his results. Do you think it is a fair experiment? Give a reason why. [1]



41. Germaine wanted to find out the electrical conductivity of rods, A, B, C and D. She set up 3 circuits with identical batteries, bulbs and wires as shown below.

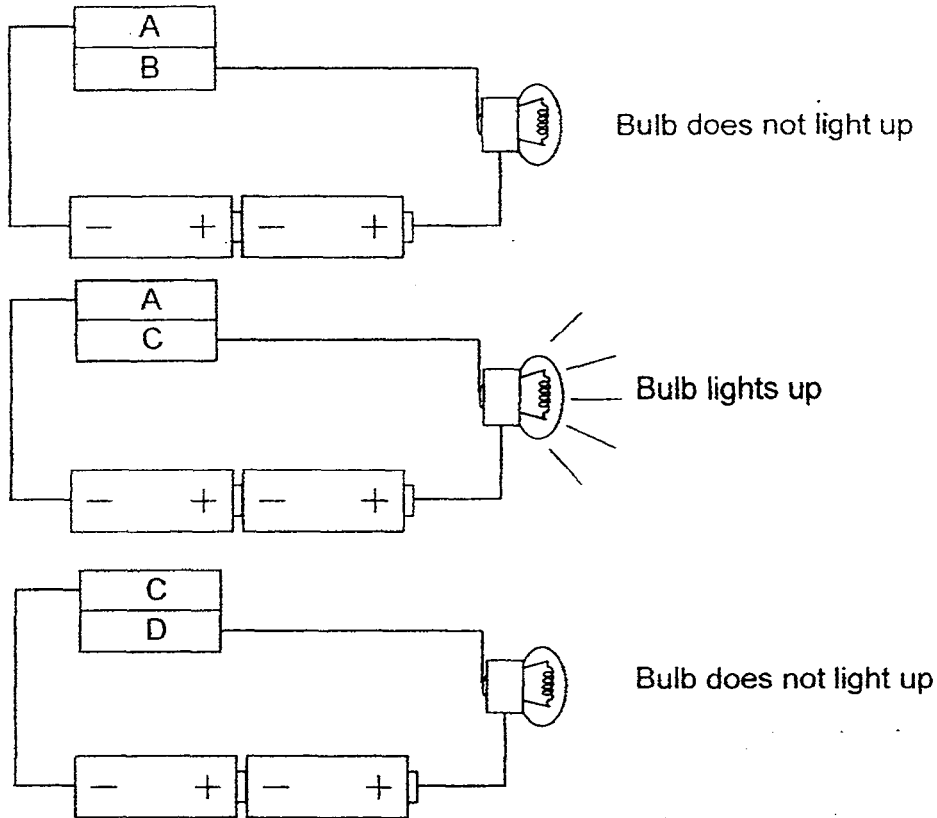

- (a) Based on Germaine's observations, complete the table with Rod, A,B, C or D, based on its electrical conductivity. [2]

Conductor(s) of electricity	Insulator(s) of electricity
(i) Rod (s) _____	(ii) Rod (s) _____

- (b) Electrical wires are normally covered with a layer of rubber. How does this layer of rubber provide protection to the people who are using the wires? [1]

42. The diagram below shows a way to separate magnetic metals and non-magnetic metals. Julian poured a mixture of metals onto the moving rubber belt.

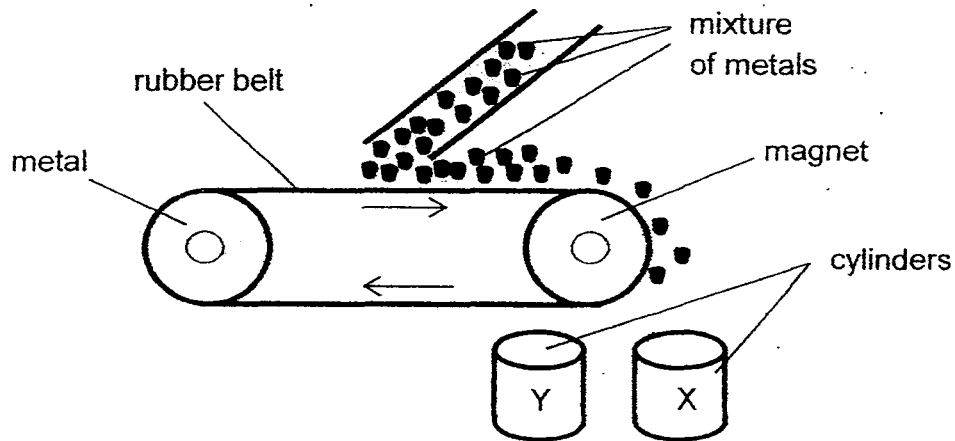

- (a) What type of metals, magnetic or non-magnetic, would be collected in cylinders X and Y respectively?

[1]

Cylinder X. _____

Cylinder Y: _____

- (b) Explain how cylinder Y is able to collect the type of metal stated in (a).

[2]



43. In the set up below, fabrics of 3 different materials were submerged into 3 separate containers containing 500ml of water. After 5 minutes; the fabrics were taken out from the containers and the amount of water left in each container was measured.

Start of experiment

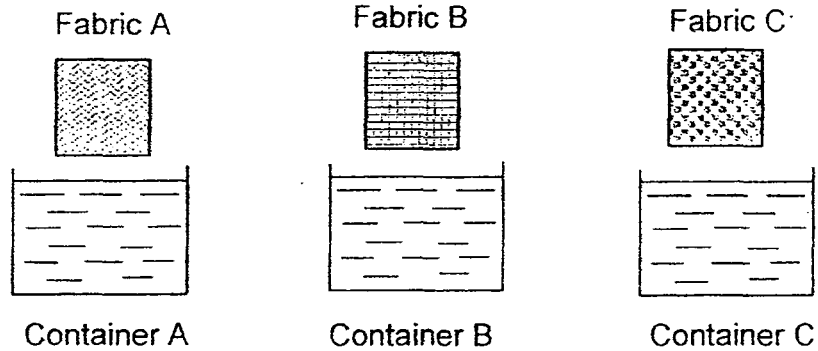

Amount of water left after the experiment

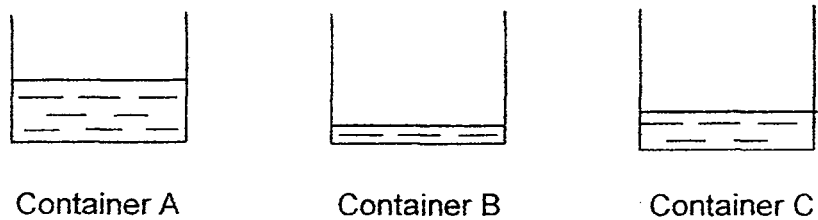

- (a) What is the aim of the experiment? [1]

- (b) If Mrs Tan wanted to choose a fabric to make bath towels, which fabric, A, B or C, would she choose? Give a reason for your answer. [1]



44. The diagram below shows two set ups, A and B.

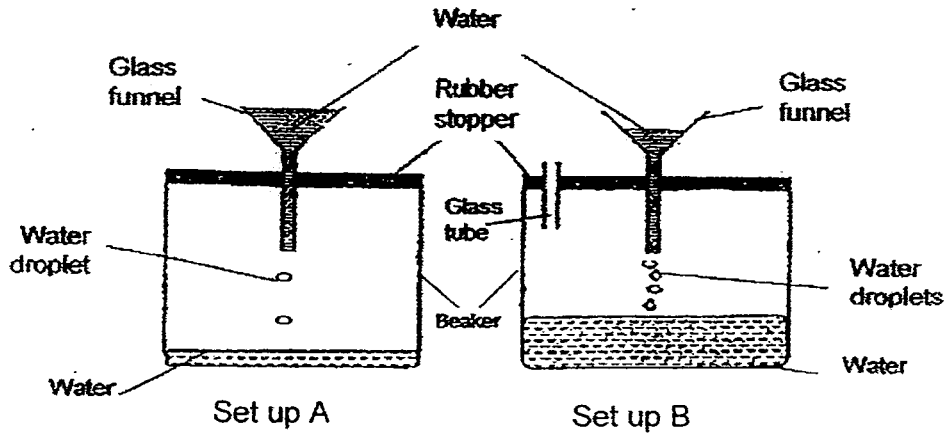

It was observed that when water was poured into both funnels, the water flowed more quickly into the beaker in set up B than that in set up A.

- (a) Explain why water could flow more easily from the funnel into the beaker in set up B.

[2]

A hole was made in a milk can. It was very difficult to pour the milk out of the can with only one hole being made as shown in the diagram below.

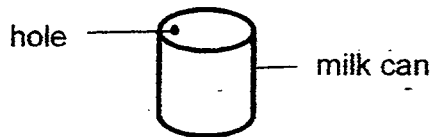

Look at milk cans, A, B and C, with holes being made as shown below.

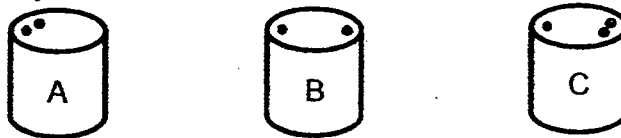

- (b) Which one of the milk cans would allow the milk to be poured out of it the fastest? Explain your answer.

[1]

End of Booklet B

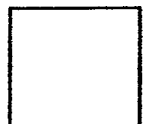



EXAM PAPER 2015

LEVEL : PRIMARY 5

SCHOOL : CHIJ ST NICHOLAS GIRLS SCHOOL

SUBJECT : SCIENCE

TERM : SA2

Q1	Q2	Q3	Q4	Q5	Q6	Q7	Q8	Q9	Q10
4	4	4	3	1	3	2	1	2	1
Q11	Q12	Q13	Q14	Q15	Q16	Q17	Q18	Q19	Q20
3	4	3	1	3	3	2	3	2	2
Q21	Q22	Q23	Q24	Q25	Q26	Q27	Q28	Q29	Q30
1	2	1	4	1	2	3	1	2	4

Q31a. Cell Q has a cell wall but cell S does not have a cell wall.

Q31b. Cell R. Cell R has a cell wall, showing that it is a plant cell and like a root cell, cell R does not have chloroplasts because it does not need to photosynthesize.

Q32a. **SEE PICTURE**

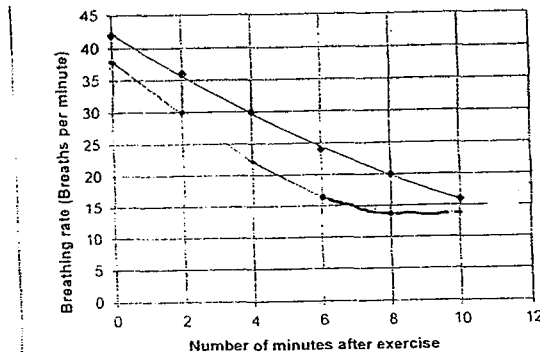

Q32b. He reached his breathing rate at rest faster than Sam.

Q33a. Carbon dioxide is given out when the seeds germinate.

Q33b. It is so that carbon dioxide which caused the limewater to turn chalky comes from the germination process and not from anywhere else.

Q33c. Some apparatus but without seeds.

Q34a. The lesser the number of wing-like structures of fruit X, the shorter the duration it remains in the air.

Q34b. So that the wind can blow the seed away to avoid overcrowding.

Q34c. Same size of seed and same shape of seed.

Q35a. Ovary. The ovary produces the mature egg cell.

Q35b. When one of P burst or does not function properly, there is still another one of P to produce the egg cell but when W burst or does not function properly, the bird cannot produce any egg cells.

Q36. **Plant** : Explosive Action. **Reason** : The young of plant are located near or around the parent plant. When the fruit splits open, the seed will not travel too far from the parent plant.

Q36. **Plant** : Animal. **Reason** : As the young of plant 2 are located in random around the garden, it is a result of animals carry the seeds away from the parent plant.

Q37a. The water in the beaker gained heat from the Bunsen burner and evaporated to become water vapour. The hot water vapor came into contact with the cooler surface of the steel plate, lost heat and condensed to form water droplets on the steel plate. Then, the water droplets slid down the steel plate and dripped into the dish.

Q37b. The steel plate gained heat from the hot water vapor and thus less water vapor could lose heat and condense on the steel plate or slowing the rate of condensation.

Q37c. There will be fewer water droplets on the plastic plate.

Q38a. **SEE PICTURE**

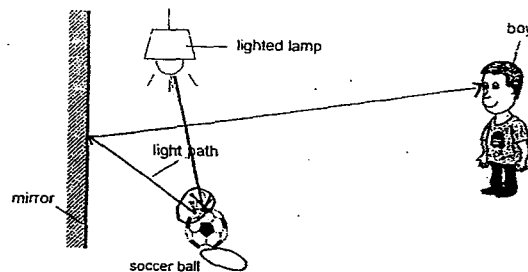

Q38b. The soccer ball blocked the path of light from the lighted lamp and casted a shadow on the floor. Light from the lamp travels in a straight line.

Q38c. Move the soccer ball nearer to the light source.

Q39a. After 20 seconds : decrease

Q39a. After 1 minute : increase

Q39b. The flask expanded first, increasing the space in the flask, thus the water level in the tube decreased. After which, the water in the flask gained heat and expanded so water level in the tube increased.

Q39c. To allow space for the metal rails to expand on hot days so that the metal rails will not buckle up.

Q40a. The amount of surface area of the water in the containers in contact with the surroundings.

Q40b. He should record the amount of water left in the beaker after the experiment.

Q40c. No, as the water in C is evaporating, the amount of surface area of the water in C is decreasing and as the water in D is evaporating, the amount of surface area of the water in D is increasing.

Q41a.i) A, C

Q41a.ii) B, D

Q41b. It is so that when the person touches the wire, the electricity will not be conducted to his hands, preventing him from getting electrocuted, because rubber is an insulator of electricity.

Q42a. Cylinder X : non magnetic Q42a. Cylinder Y : magnetic

Q42b. As the mixture of metals move to the magnet, the magnetic materials get attracted to it whereas the non-magnetic material falls into cylinder X. As the magnetic material move away from the magnet, the magnetic attraction between them weakened, causing the magnetic materials to fall into cylinder Y.

Q43a. To find out which fabric can absorb the most water.

Q43b. B. The amount of water left in beaker B was the least, so B was the most absorbent and a bath needs to be absorbent to absorb the water from one's body the fastest.

Q44a. Water is able to flow into the beaker to take over the space.

Q44b. C. W holes to allow milk to flow out faster and a hole to allow air to flow into the can.

THE END

