

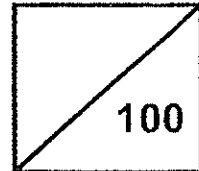

**Rosyth School**  
**First Semestral Assessment 2015**  
**Mathematics**  
**Primary 4**

Total



Name: \_\_\_\_\_

Class: Pr 4 - \_\_\_\_\_ Register No. \_\_\_\_\_

Duration: 1h 45 min

Date: 12 May 2015

Parent's Signature: \_\_\_\_\_

**Instructions to Pupils:**

1. Do not open this booklet until you are told to do so.
2. Follow all instructions carefully.
3. This paper consists of 3 parts, Sections A, B and C.
4. For questions 1 to 20 in Section A, shade the correct ovals on the Optical Answer Sheet (OAS).
5. ANSWER ALL THE QUESTIONS.

	<b>Maximum</b>	<b>Marks Obtained</b>
<b>Section A</b>	<b>40</b>	
<b>Section B</b>	<b>40</b>	
<b>Section C</b>	<b>20</b>	
<b>Total</b>	<b>100</b>	

\* This paper consists of 20 pages altogether.

**Section A (40 marks)**

For questions 1 to 20, four options are given. One of them is the correct answer. Make your choice (1, 2, 3 or 4). Shade the correct ovals (1, 2, 3 or 4) onto the Optical Answer Sheet provided. Each question carries 2 marks.

---

1. In 51 672, the digit '6' stands for \_\_\_\_\_.

- (1) 6
- (2) 60
- (3) 600
- (4) 6 000

2. In which of the numbers below, does the digit '7' have the smallest value?

- (1) 10 407
- (2) 37 651
- (3) 40 700
- (4) 81 872

3. The product of 341 and 27 is \_\_\_\_\_.

- (1) 2 387
- (2) 8 107
- (3) 9 007
- (4) 9 207

4. The figure below is made up of identical squares.

What fraction of the figure is shaded?

- (1)  $\frac{5}{7}$
- (2)  $\frac{5}{12}$
- (3)  $\frac{7}{12}$
- (4)  $\frac{7}{5}$

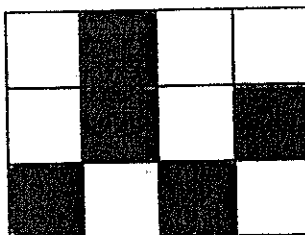

5. What is the value of  $\frac{1}{3} + \frac{7}{12}$  ?

(1)  $\frac{2}{3}$

(2)  $\frac{8}{3}$

(3)  $\frac{11}{12}$

(4)  $\frac{8}{15}$

6. What is  $\angle x$  in the rectangle ABCD shown below?

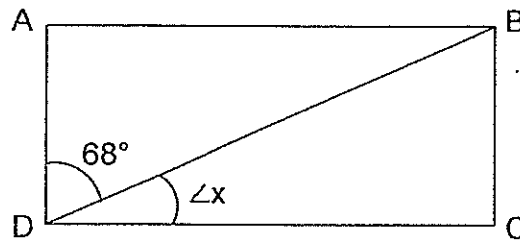

(1)  $12^\circ$

(2)  $22^\circ$

(3)  $32^\circ$

(4)  $112^\circ$

7. The figure below is made up of 3 similar squares. Find length EF.

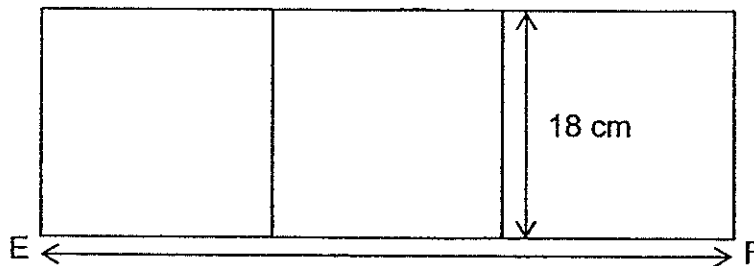

(1) 18 cm

(2) 54 cm

(3) 144 cm

(4) 180 cm

8. The line graph below shows the PSI readings for a particular day. Study it carefully and answer question 8.

**Daily PSI Readings**

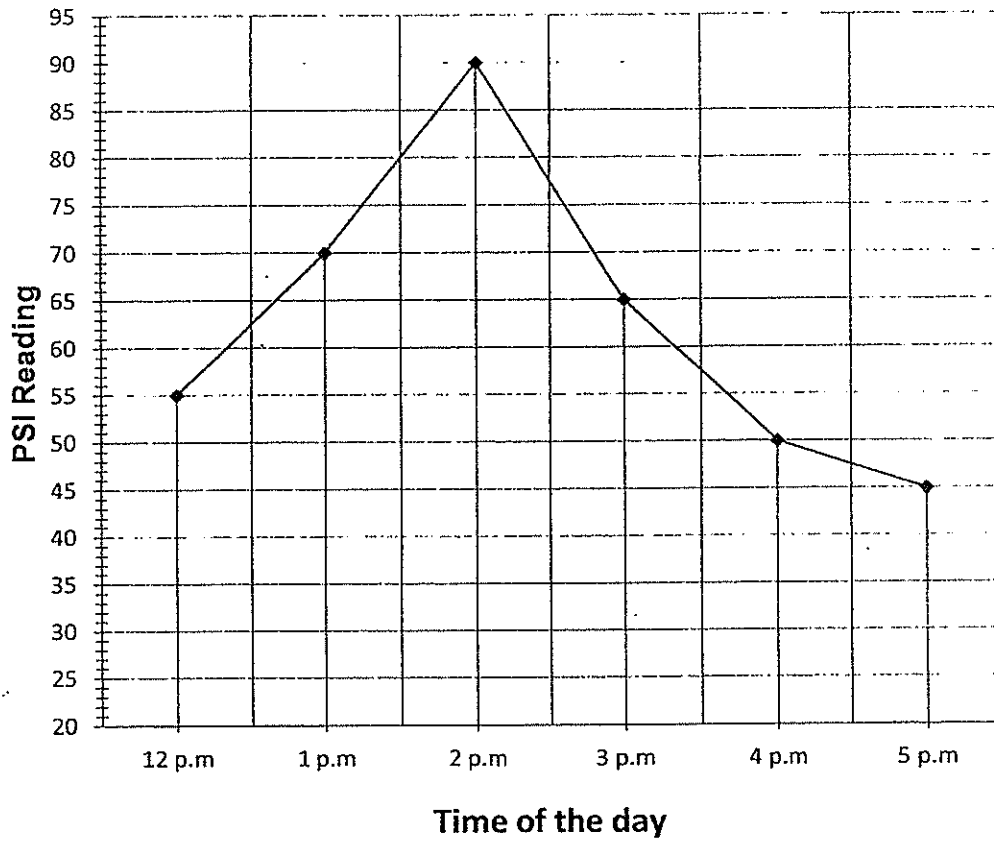

What is the difference in PSI reading between 4 p.m. and 5 p.m.?

- (1) 5
- (2) 15
- (3) 20
- (4) 25

9. A square has an area of  $144 \text{ cm}^2$ . What is the perimeter of the same square?

- (1) 12 cm
- (2) 36 cm
- (3) 48 cm
- (4) 144 cm

10. Which one of the following is a common factor of 18 and 24?

- (1) 6
- (2) 9
- (3) 12
- (4) 4

11.  $40 \times 80 = \boxed{\phantom{0000}}$  tens

- (1) 32
- (2) 48
- (3) 320
- (4) 3200

12. Find the difference between the 4<sup>th</sup> multiple of 8 and the 7<sup>th</sup> multiple of 7.

- (1) 15
- (2) 17
- (3) 28
- (4) 81

13. How many sixths are there in  $6\frac{2}{3}$ ?

- (1) 6
- (2) 11
- (3) 20
- (4) 40

14.  $\frac{3}{5}$  of a number is 15. What is the number?

- (1) 25
- (2) 30
- (3) 45
- (4) 75

15. Adam used 4 similar rectangular strips to form a square. If the perimeter of the square is 64 cm, what is the perimeter of a rectangular strip of paper?

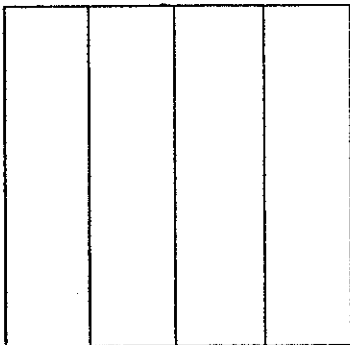

- (1) 16 cm
- (2) 20 cm
- (3) 40 cm
- (4) 256 cm

16. The figure below is made up of a square ABCD and a rectangle DEFG.

Find  $\angle ADG$ .

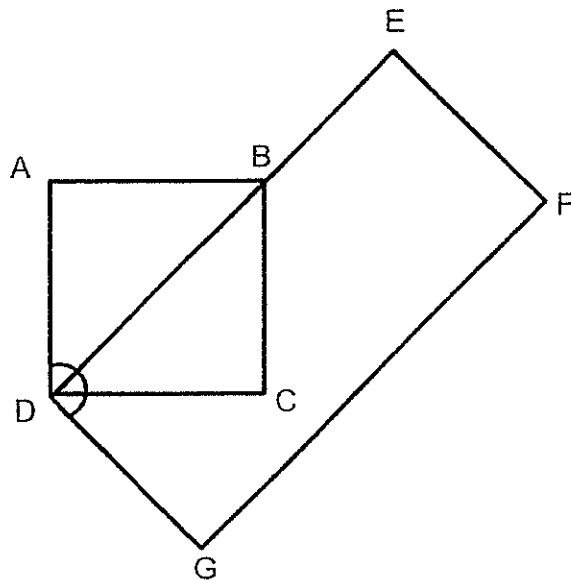

- (1)  $45^\circ$
- (2)  $90^\circ$
- (3)  $135^\circ$
- (4)  $180^\circ$

17. A number is 2 000 when rounded off to the nearest hundred.

What is the number?

- (1) 1 901
- (2) 1 949
- (3) 2 001
- (4) 2 051

18. Jaden had 6 546 stamps.

After giving away 410 stamps, he rearranged the remaining stamps equally into 8 albums. How many stamps were there in each album?

- (1) 767
- (2) 818
- (3) 6 136
- (4) 6 956

19. Benjamin made 35 tarts. He gave  $\frac{2}{7}$  of it to Ali.  
How many tarts did he give to Ali?

- (1) 7
- (2) 10
- (3) 14
- (4) 49

20. Harris sold 8 cats, 5 hamsters and some birds.  
He sold 7 more birds than hamsters.  
What fraction of the total number of animals sold were hamsters?

- (1)  $\frac{1}{4}$
- (2)  $\frac{1}{5}$
- (3)  $\frac{5}{8}$
- (4)  $\frac{5}{12}$



**Section B (40 marks)**

For questions 21 to 40, show your working clearly in the space below each question and write your answer in the answer boxes provided. Give your answers in the units stated. Each question carries 2 marks.

---

21. What is the value of the digit '5' in 32 154?

22. What is the first common multiple of 6 and 8?

23. What is the missing number in the number pattern below?

34 456, 34 756, \_\_\_\_\_, 35 356, 35 656

24. A number is 2 900 when rounded off to the nearest ten.  
What is the greatest possible number?

25. Express  $\frac{33}{6}$  as a mixed number in its simplest form.

26. Find the value of  $\frac{7}{9} - \frac{1}{3}$ .

27. In the number line below, what is the value of Y?  
Express your answer as a mixed number in its simplest form.

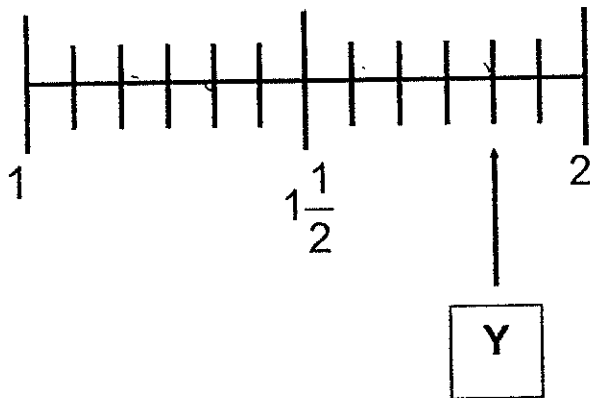

28. In the figure below (not drawn to scale), ABCD is a rectangle and EGCF is a square. The area of EGCF is  $81\text{cm}^2$ . Find the length of BG.

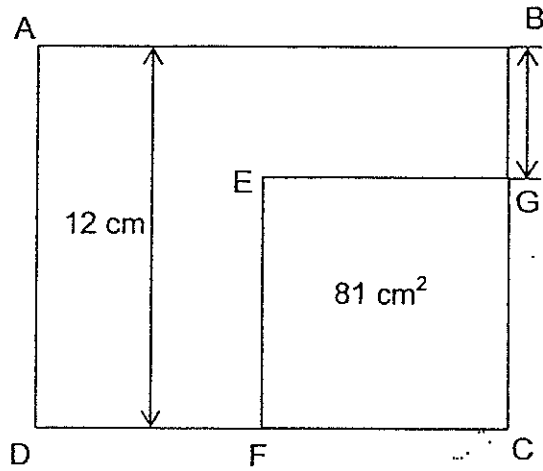
 cm

29. Find  $\angle AOC$ .

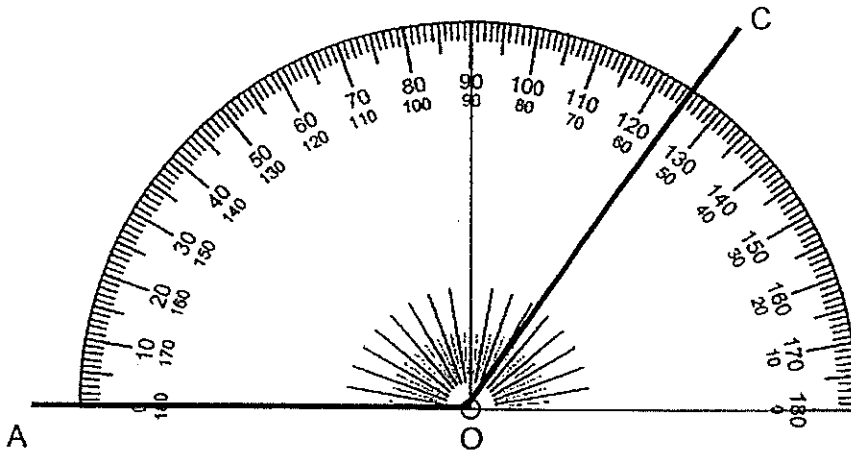

30. AB is a straight line. Draw a line perpendicular to the line AB through the point Y.

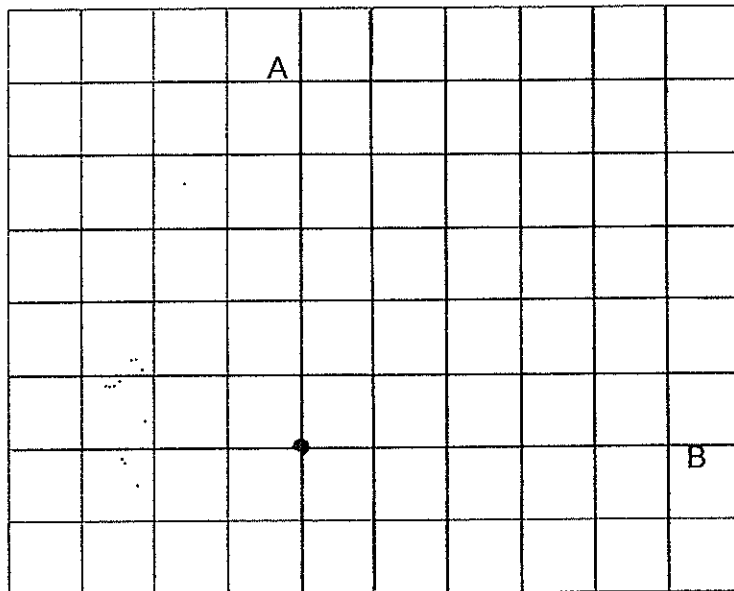

31. The perimeter of rectangle QRST is 106 cm. What is the area of the rectangle QRST?

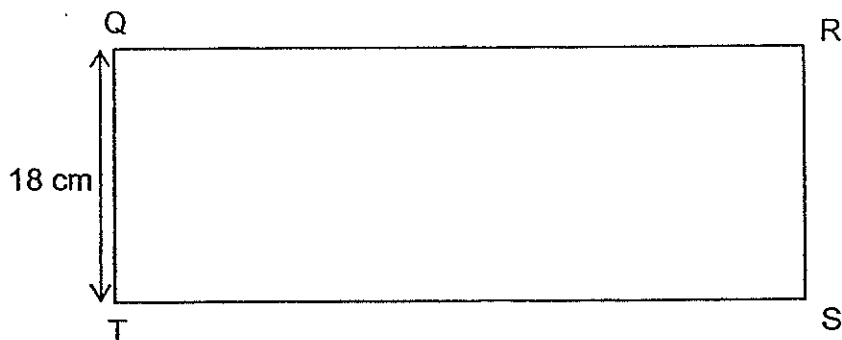

cm<sup>2</sup>

32. A computer costs \$ 2 120. A television cost 3 times as much as the computer. Find the cost of the television.

\$
----

33. Arrange the following fractions from the greatest to the smallest.

$\frac{1}{2}$ , $\frac{3}{4}$ , $\frac{5}{8}$
-----------------------------------------------

<table border="1"><tr><td></td></tr></table>		,	<table border="1"><tr><td></td></tr></table>		,	<table border="1"><tr><td></td></tr></table>	
<b>Greatest</b>				<b>Smallest</b>			

34. Jug A has  $\frac{5}{6}$  ℓ of water. Jug B has  $\frac{2}{3}$  ℓ of water.  
Find the total amount of water in both jugs. Express your answer as a mixed number in its simplest form.

--

Using the information given in the graph below, complete the questions 35 and 36.

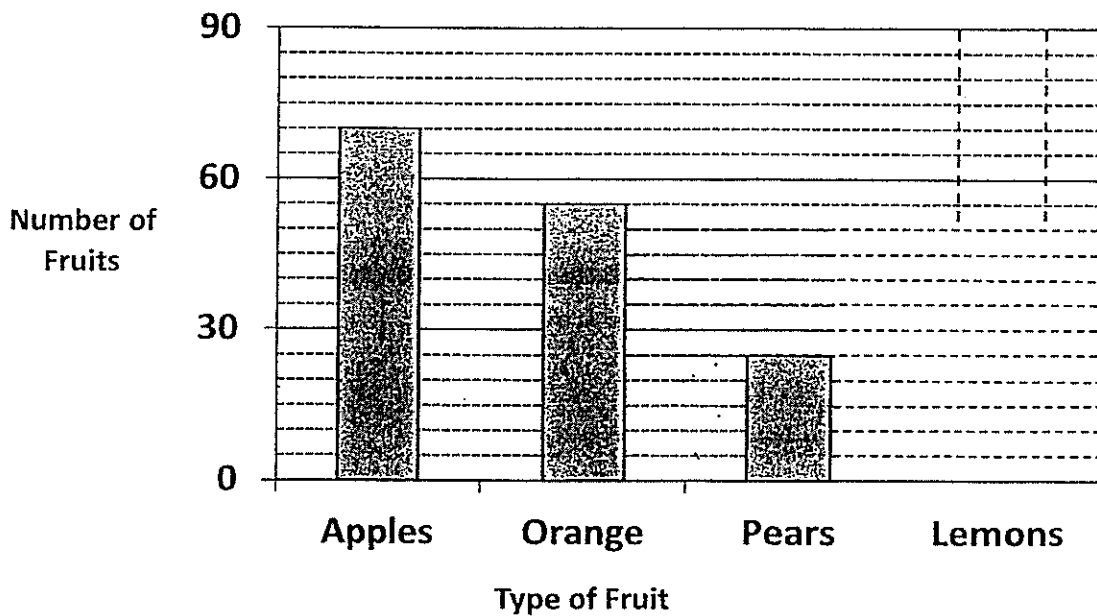

35. Complete the table below to show the information given above.

Fruits	Number of fruits
Apples	
Oranges	
Pears	25

36. The number of lemons is twice the number of pears.  
Draw the bar for the number of lemons in the graph above.

37. How many angles in the figure given below are more than  $90^\circ$ ?

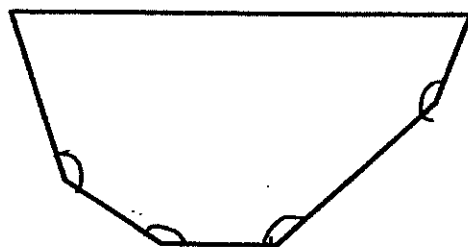

38. Mrs Tan bought 4 kg of grapes. She kept 2 kg of the grapes for her sons, ate  $\frac{1}{4}$  kg and gave the rest to her neighbours. How many kilograms of grapes did she give to her neighbours?

kg
----

39. Name a pair of parallel lines in the figure below.

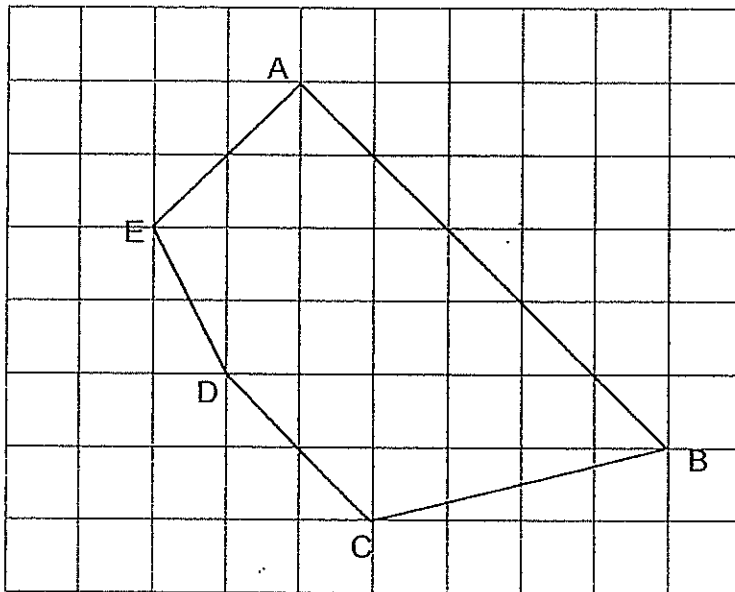

--

40. Stephanie had some flour in a container. She used  $2\frac{1}{4}$  kg of the flour in the morning. She added 3kg of flour into the same container in the afternoon. There was  $3\frac{1}{8}$  kg of flour in the container in the end. How much flour did Stephanie have at first? Express your answer in its simplest form.

kg
----

**Section C (20 marks)**

For questions 41 to 45, show your working clearly in the space below each question and write your answers in the blanks provided. The marks for each question or part question are given in the brackets.

---

41. Mr Smith saved a total of \$8 540 in 6 months.  
In the first 4 months, he saved \$1 210 each month.  
In the 5<sup>th</sup> month, he saved \$1 530.  
How much did he save in the 6<sup>th</sup> month?

Answer: \_\_\_\_\_ (4 m)



42. The graph below shows how all the P4 students get to school.

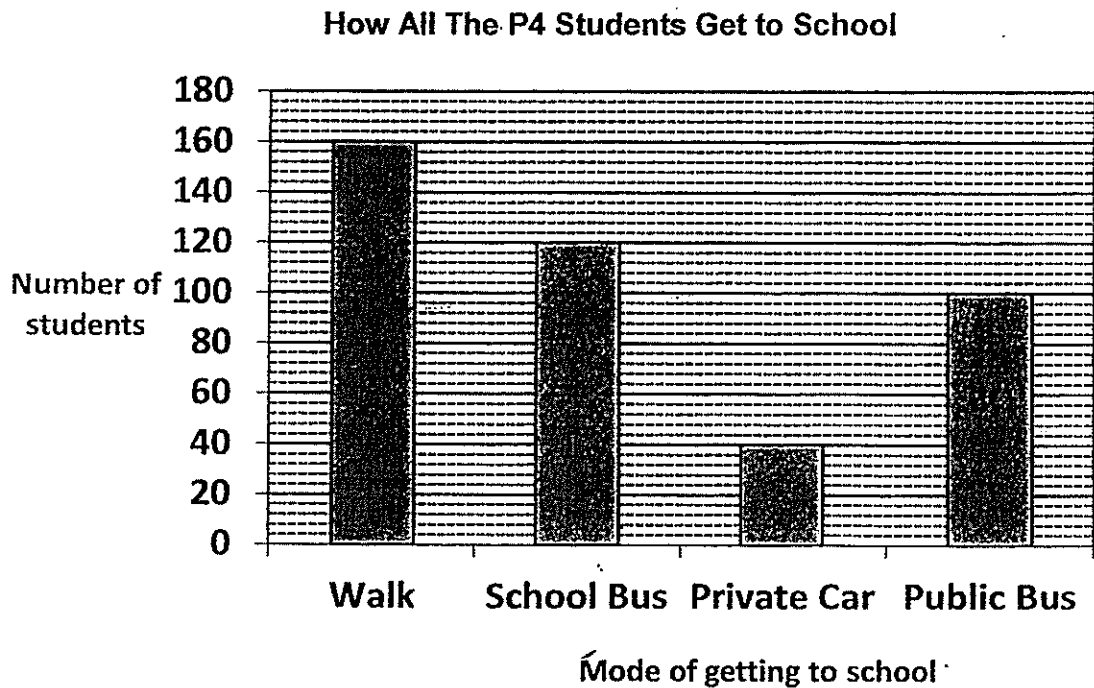

- (a) What is the total number of students in P4?
- (b) Some students who walk to school changed to take the private car instead. The number of students who walk to school became three times as many as the number of students who take the private car. How many P4 students take the private car to school now?

Answer: a) \_\_\_\_\_ (1 m)

b) \_\_\_\_\_ (3 m)

43. There are some pineapple tarts in a container.  
The pineapple tarts can be put into plates of 4 or 8 with no pineapple tarts leftover.  
When the pineapple tarts are put into plates of 6, there are short of 2 pineapple tarts on the last plate.  
If there are more than 50 pineapple tarts but less than 70 pineapple tarts, how many pineapple tarts are there in the container?

Answer: \_\_\_\_\_ (4 m)

44. Erliana had a sum of money. She spent  $\frac{1}{8}$  of her money on toys and  $\frac{1}{2}$  of her money on books. She had \$60 left after buying all the items. How much did she spend on the toys?

Answer: \_\_\_\_\_ (4 m)

45. Stanley used 3 similar rectangles and 2 similar squares to make the figure below (not drawn to scale).

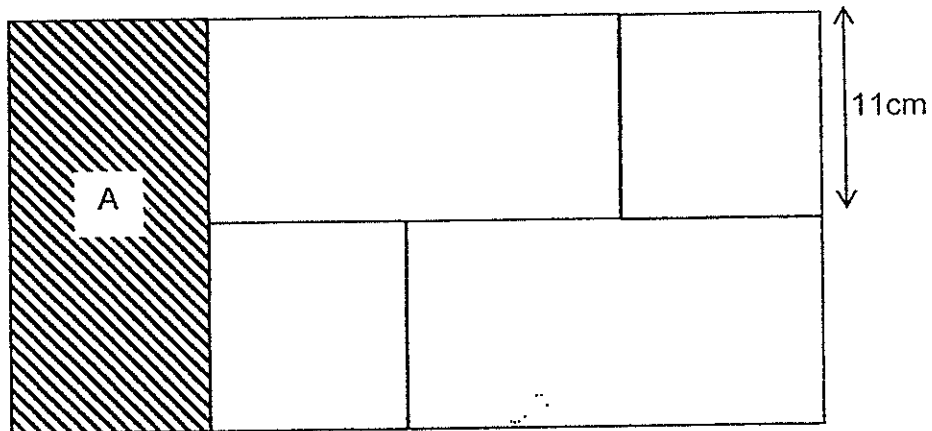

- (a) Find the area of A.  
(b) Find the area of the figure.

Answer: (a) \_\_\_\_\_ (2m)  
(b) \_\_\_\_\_ (2m)

**~END OF PAPER~**  
*Have you checked your work thoroughly?*

**EXAM PAPER 2015**  
**LEVEL : PRIMARY 4**  
**SCHOOL : ROYSTH SCHOOL**  
**SUBJECT : MATHS**  
**TERM : SA1**

Q1	Q2	Q3	Q4	Q5	Q6	Q7	Q8	Q9	Q10
3	1	4	2	3	2	2	1	3	1
Q11	Q12	Q13	Q14	Q15	Q16	Q17	Q18	Q19	Q20
3	2	2	3	2	3	3	1	2	1

Q21. 50. Q22. 24.  $\rightarrow 6, 12, 28, 24, 30, 8, 16, 24$ . Q23. 35056.  $\rightarrow 34756 + 300 = 35056$ . Q24. 2904.  
 Q25.  $5\frac{1}{2} \rightarrow \frac{33}{6} = 5\frac{3}{6}$ ,  $5\frac{3}{6} = 5\frac{1}{2}$ . Q26.  $\frac{4}{9} \rightarrow \frac{1}{3} = \frac{3}{9}$ ,  $\frac{7}{9} - \frac{3}{9} = \frac{4}{9}$   
 Q27.  $1\frac{5}{6}$ , Q28. 3cm.  $\rightarrow 9 \times 9 = 81$ ,  $12 - 9 = 3$ , Q29.  $125^\circ$ .

Q30. SEE PICTURE

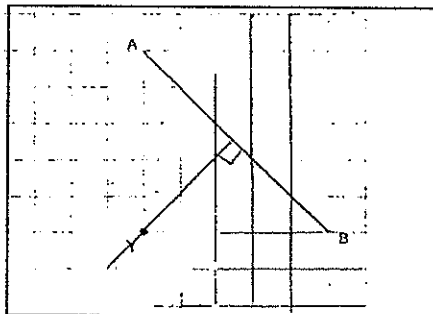

Q31.  $630\text{cm}^2 \rightarrow 18 \times 2 = 36$ ,  $70 \div 2 = 35$ ,  $35 \times 18 = 630$ . Q32.  $\$6360 \rightarrow 2120 \times 3 = 6360$ . Q33.  $\frac{3}{4}, \frac{5}{8}, \frac{1}{2}$   
 Q34.  $1\frac{1}{2}$  litre,  $\frac{5}{6} + \frac{2}{3} = \frac{5}{6} + \frac{4}{6} = \frac{9}{6}$ . Q35. 70, 55, 25.  
 Q36. SEE PICTURE

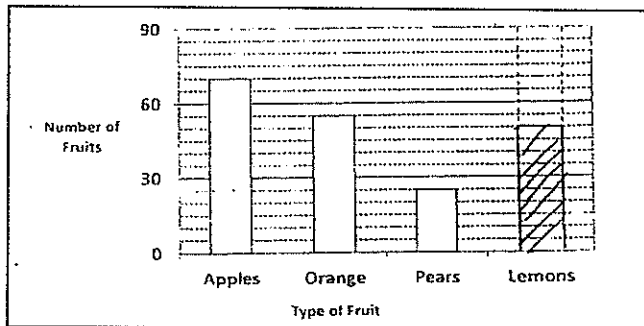

Q37. 4. Q38.  $1\frac{3}{4}\text{kg} \rightarrow 4 - 2 = 2$ ,  $2 - \frac{1}{4} = 1\frac{3}{4}$ . Q39. AB parallel to DC.  
 Q40.  $2\frac{3}{8}\text{kg} \rightarrow 3\frac{1}{8} - 3 = \frac{1}{8}$  (before adding 3kg),  $2\frac{1}{4} = 2\frac{2}{8}$ ,  $2\frac{2}{8} + \frac{1}{8} = 2\frac{3}{8}$   
 Q41.  $\$2170 \rightarrow 4$  months =  $1210 \times 4 = 4840$ ,  $5^{\text{th}} + 4^{\text{th}}$  month =  $4840 + 1530 = 6370$ ,  $6^{\text{th}}$  month =  $8540 - 6370 = 2170$ .  
 Q42. a) 420  $\rightarrow$  a)  $160 + 120 = 40 + 100 = 420$ , b) 50  $\rightarrow 160 - 10 = 150$ ,  $40 + 10 = 50$

Q43. 64 pineapples.

4	52	56	60	64	68
8	56	64			
6	54	60	66		
-2	52	58	64		

Q44.  $\$20\frac{1}{2} = \frac{4}{8}$ , Toys =  $\frac{1}{8}$ , books =  $\frac{4}{8}$ , altogether =  $\frac{4}{8} + \frac{1}{8} = \frac{5}{8}$ ,  $\frac{3}{8}$  of her money = 60,  $\frac{1}{8}$  of her money =  $60 \div 3 = 20$ .  
 Q45. a)  $242\text{cm}^2 \rightarrow 11 \times 2 = 22$ ,  $11 \times 22 = 242$ . b)  $968\text{cm}^2 \rightarrow 11 \times 3 = 33$ ,  $33 \times 22 = 726$ ,  $726 + 242 = 968$ .

**THE END**

